

Компания Полель - официальный
дистрибьютор **SANYO**

www.poulel.ru
www.sanyo-airservice.ru

т. (495) 101-30-99

Кондиционеры
Сплит-системы
Полупромышленные кондиционеры
Мультizonальные **VRF** системы кондиционирования
Чиллеры

SAP-KM97GHS5A(×2) + SAP-MC1827GH5
 SAP-KM97GHS5A/E(×2) + SAP-MC1827GH5

FILE NO.

MULTI-SPLIT SYSTEM AIR CONDITIONER

Indoor Model No	Product Code No.
SAP-KM97GHS5A-S	1 852 659 06
SAP-KM97GHS5A/E-S	1 852 658 85

Outdoor Model No.	Product Code No.
SAP-MC1827GH5-S	1 852 753 90
SAP-MC1827GH5-E	1 852 754 06

Indoor Unit

Outdoor Unit

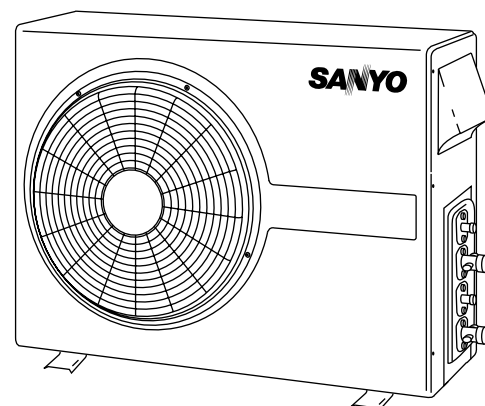
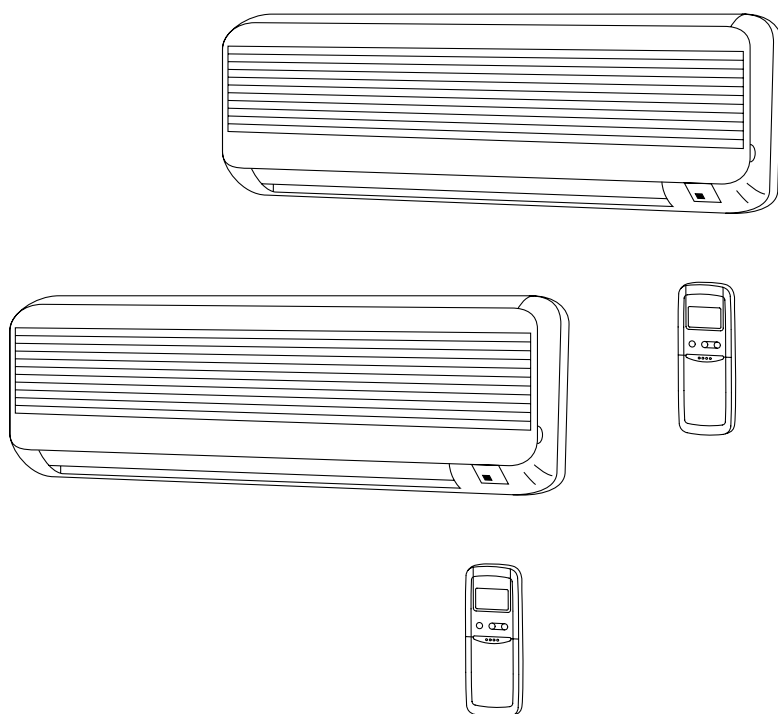

SAP-MC1827GH5

SAP-KM97GHS5A
 SAP-KM97GHS5A/E

IMPORTANT!

Please Read Before Starting

This air conditioning system meets strict safety and operating standards. As the installer or service person, it is an important part of your job to install or service the system so it operates safely and efficiently.

For safe installation and trouble-free operation, you must:

- Carefully read this instruction booklet before beginning.
- Follow each installation or repair step exactly as shown.
- Observe all local, state, and national electrical codes.
- Pay close attention to all warning and caution notices given in this manual.



WARNING

This symbol refers to a hazard or unsafe practice which can result in severe personal injury or death.



CAUTION

This symbol refers to a hazard or unsafe practice which can result in personal injury or product or property damage.

If Necessary, Get Help

These instructions are all you need for most installation sites and maintenance conditions. If you require help for a special problem, contact our sales/service outlet or your certified dealer for additional instructions.

In Case of Improper Installation

The manufacturer shall in no way be responsible for improper installation or maintenance service, including failure to follow the instructions in this document.

SPECIAL PRECAUTIONS

WARNING When Wiring



ELECTRICAL SHOCK CAN CAUSE SEVERE PERSONAL INJURY OR DEATH. ONLY A QUALIFIED, EXPERIENCED ELECTRICIAN SHOULD ATTEMPT TO WIRE THIS SYSTEM.

- Do not supply power to the unit until all wiring and tubing are completed or reconnected and checked.
- Highly dangerous electrical voltages are used in this system. Carefully refer to the wiring diagram and these instructions when wiring. Improper connections and inadequate grounding can cause **accidental injury or death.**
- **Ground the unit** following local electrical codes.
- Connect all wiring tightly. Loose wiring may cause overheating at connection points and a possible fire hazard.

When Transporting

Be careful when picking up and moving the indoor and outdoor units. Get a partner to help, and bend your knees when lifting to reduce strain on your back. Sharp edges or thin aluminum fins on the air conditioner can cut your fingers.

When Installing...

...In a Ceiling or Wall

Make sure the ceiling/wall is strong enough to hold the unit's weight. It may be necessary to construct a strong wood or metal frame to provide added support.

...In a Room

Properly insulate any tubing run inside a room to prevent "sweating" that can cause dripping and water damage to walls and floors.

...In Moist or Uneven Locations

Use a raised concrete pad or concrete blocks to provide a solid, level foundation for the outdoor unit. This prevents water damage and abnormal vibration.

...In an Area with High Winds

Securely anchor the outdoor unit down with bolts and a metal frame. Provide a suitable air baffle.

...In a Snowy Area (for Heat Pump-type Systems)

Install the outdoor unit on a raised platform that is higher than drifting snow. Provide snow vents.

When Connecting Refrigerant Tubing

- Use the flare method for connecting tubing.
- Apply refrigerant lubricant to the matching surfaces of the flare and union tubes before connecting them, then tighten the nut with a torque wrench for a leak-free connection.
- Check carefully for leaks before starting the test run.

When Servicing

- Turn the power OFF at the main power box (mains) before opening the unit to check or repair electrical parts and wiring.
- Keep your fingers and clothing away from any moving parts.
- Clean up the site after you finish, remembering to check that no metal scraps or bits of wiring have been left inside the unit being serviced.

Others



CAUTION

- Ventilate any enclosed areas when installing or testing the refrigeration system. Escaped refrigerant gas, on contact with fire or heat, can produce dangerously toxic gas.
- Confirm upon completing installation that no refrigerant gas is leaking. If escaped gas comes in contact with a stove, gas water heater, electric room heater or other heat source, it can produce dangerously toxic gas.

Table of Contents

	Page
■ Unit Combination.....	iv
1. OPERATING RANGE	1
2. SPECIFICATIONS	
2-1. Unit Specifications.....	2
2-2. Major Component Specifications.....	4
2-3. Other Component Specifications.....	6
3. DIMENSIONAL DATA	7
4. COOLING CAPACITY	9
5. HEATING CAPACITY	10
6. AIR THROW DISTANCE CHART	11
7. REFRIGERANT FLOW DIAGRAM	12
8. ELECTRICAL DATA	
8-1. Electrical Characteristics.....	14
8-2. Electric Wiring Diagram.....	15
9. INSTALLATION INSTRUCTIONS	
9-1. Installation Site Selection	17
9-2. Remote Control Unit Installation Position	19
9-3. Recommended Wire Length and Diameter	20
10. FUNCTION	
10-1. Room Temperature Control	21
10-2. Dry Operation.....	23
10-3. Freeze Prevention	24
10-4. Overload Prevention.....	24
10-5. Cold draft Prevention.....	25
10-6. Defrosting Operation	26
11. TROUBLESHOOTING	
11-1. Check before and after troubleshooting	28
11-1-1. Check power supply wiring.....	28
11-1-2. Check inter-unit wiring.....	28
11-1-3. Check power supply	28
11-1-4. Check lead wires and connectors in indoor and outdoor units.....	28

11-2. Air conditioner does not operate	29
11-2-1. Circuit breaker trips (or fuse blows).....	29
A. When the circuit breaker is set to ON, it is tripped soon	29
B. Circuit breaker trips in several minutes after turning the air conditioner on	29
11-2-2. Neither indoor nor outdoor unit runs.....	30
A. Power is not supplied	30
B. Check "OPERATION selector" switch in the indoor unit	30
C. Check remote control unit.....	30
D. Check fuse on the indoor PCB Ass'y	31
E. Check TIMER SELECT button on the remote control unit.	31
11-2-3. Only outdoor unit does not run.....	32
A. Check setting temperature.....	32
B. Check PCB Ass'y in either indoor or outdoor unit.....	32
11-2-4. Only indoor unit does not run.....	32
11-3. Some part of air conditioner does not operate.	33
11-3-1. Only indoor fan does not run.....	33
11-3-2. Only flap motor does not run.....	33
11-3-3. Only outdoor fan does not run.	33
11-3-4. Only compressor does not run.....	34
11-4. Air conditioner operates, but abnormalities are observed.	35
11-4-1. Operation does not switch from HEAT to COOL (or COOL to HEAT).	35
11-4-2. Poor cooling or heating.	36
11-4-3. Excessive cooling or heating.	36
11-5. If a sensor is defective.....	37
11-5-1. Indoor coil temp. thermistor (TH1) is defective.....	37
11-5-2. Room temp. thermistor (TH2) is defective.....	37
12. ARRANGEMENT OF ELECTRICAL COMPONENTS	38
13. CHECKING ELECTRICAL COMPONENTS	
13-1. Measurement of insulation resistance.....	40
13-1-1. Power supply wires.....	40
13-1-2. Indoor unit	40
13-1-3. Outdoor unit.....	40
13-1-4. Measurement of insulation resistance for electrical parts	40
13-2. Checking continuity of Fuse on PCB Ass'y	41
13-3. Checking motor capacitor.....	41
APPENDIX INSTRUCTION MANUAL	42

■ Unit Combination

Combine indoor and outdoor units only as listed below.

Outdoor Unit	Indoor Unit	Symbol of Indoor Unit	Refer to
SAP-MC1827GH5	KM97	A	Fig.1
	KM97	B	

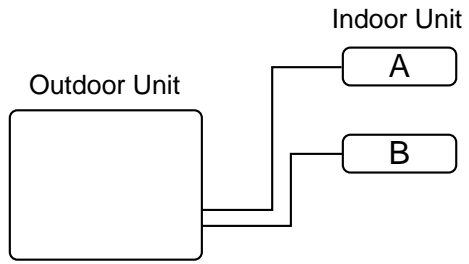

Fig.1

1. OPERATING RANGE

	Temperature	Indoor Air Intake Temp.	Outdoor Air Intake Temp.
Cooling	Maximum	35°C DB / 22°C WB	46°C DB
	Minimum	19°C DB / 14°C WB	19°C DB
Heating	Maximum	27°C DB	24°C DB / 18°C WB
	Minimum	16°C DB	-8°C DB / -9°C WB

2. SPECIFICATIONS

2-1. Unit Specifications

Indoor Unit **SAP-KM97GHS5A or SAP-KM97GHS5A /E**
 Outdoor Unit **SAP-MC1827GH5**

No. of indoor units.				1-unit	
Power Source				220 – 240 V ~ 50 Hz	
Performance	Capacity	kW	Cooling		Heating
		BTU/h	2.60 / 2.60 / 2.65	3.25 / 3.25 / 3.30	
	Air circulation (High)	m ³ /h	8,900 / 8,900 / 9,000	11,100 / 11,100 / 11,300	
	Moisture removal (High)	Liters/h	450	—	
Electrical Rating	Voltage rating	V	220 / 230 / 240		
	Available voltage range	V	198 to 264		
	Running amperes	A	4.6 / 4.6 / 4.6	5.1 / 5.0 / 4.9	
	Power input	W	990 / 1,010 / 1,040	1,090 / 1,090 / 1,090	
	Power factor	%	98 / 95 / 94	97 / 95 / 93	
	C.O.P.	W/W	2.6 / 2.6 / 2.5	3.0 / 3.0 / 3.0	
	Compressor locked rotor amperes	A	23 / 24 / 25		
Features	Controls / Temperature control			Microprocessor / I.C. thermostat	
	Control unit			Wireless remote control unit	
	Timer			1-hour OFF / 12-hour ON or OFF	
	Fan speeds		Indoor / Outdoor	3 and Auto / 1	
	Airflow direction (Indoor)	Horizontal		Manual	
		Vertical		Auto	
	Air filter			Washable, Anti-Mold	
	Compressor			Rotary (Hermetic)	
	Refrigerant / Amount charged at shipment		g	R22 / 1,200	
	Refrigerant control			Capillary tube	
	Operation sound	Indoor – Hi / Me / Lo	dB-A	40 / 34 / 31	
		Outdoor – Hi	dB-A	53	
	Refrigerant tubing connections			Flare type	
	Max. allowable tubing length at shipment		m	7.5	
	Refrigerant tube diameter	Narrow tube	mm (in.)	6.35 (1/4)	
Wide tube		mm (in.)	9.52 (3/8)		
Refrigerant tube kit / Accessories			Optional / Hanging wall bracket		
Dimensions & Weight	Unit dimensions	Height	mm	Indoor Unit	Outdoor Unit
		Width	mm	265	630
		Depth	mm	805	830
	package dimensions	Height	mm	145	305
		Width	mm	208	713
		Depth	mm	855	994
	Weight	Net	kg	326	413
		Shipping	kg	7.5	61.0
	Shipping volume	m ³		10.0	66.0
			0.06	0.29	

DATA SUBJECT TO CHANGE WITHOUT NOTICE.

Remarks: Rating conditions are:

Cooling: Indoor air temperature 27°C DB/19°C WB
 Outdoor air temperature 35°C DB/24°C WB
 Heating: Indoor air temperature 20°C DB
 Outdoor air temperature 7°C DB/6°C WB

Indoor Unit **SAP-KM97GHS5A or SAP-KM97GHS5A /E**
 Outdoor Unit **SAP-MC1827GH5**

No. of indoor units.				2-unit		
Power Source				220 – 240 V ~ 50 Hz		
Performance	Capacity		kW	5.00 / 5.00 / 5.10	6.30 / 6.30 / 6.35	
			BTU/h	17,100 / 17,100 / 17,400	21,500 / 21,500 / 21,700	
	Air circulation (High)		m ³ /h	450 x 2		
	Moisture removal (High)		Liters/h	1.1 x 2	—	
Electrical Rating	Voltage rating		V	220 / 230 / 240		
	Available voltage range		V	198 to 264		
	Running amperes		A	9.5 / 9.3 / 9.1	9.2 / 9.0 / 8.9	
	Power input		W	2,040 / 2,080 / 2,120	1,980 / 1,980 / 2,000	
	Power factor		%	98 / 97 / 97	98 / 96 / 94	
	C.O.P.		W/W	2.5 / 2.4 / 2.4	3.2 / 3.2 / 3.2	
	Compressor locked rotor amperes		A	46 / 48 / 50		
Features	Controls / Temperature control			Microprocessor / I.C. thermostat		
	Control unit			Wireless remote control unit		
	Timer			1-hour OFF / 12-hour ON or OFF		
	Fan speeds		Indoor / Outdoor	3 and Auto / 1		
	Airflow direction (Indoor)		Horizontal	Manual		
			Vertical	Auto		
	Air filter			Washable, Anti-Mold		
	Compressor			Rotary (Hermetic)		
	Refrigerant / Amount charged at shipment		g	R22 / 1,200 x 2		
	Refrigerant control			Capillary tube		
	Operation sound		Indoor – Hi / Me / Lo	dB-A		
			Outdoor – Hi	dB-A		
	Refrigerant tubing connections			Flare type		
	Max. allowable tubing length at shipment		m	7.5		
	Refrigerant tube diameter		Narrow tube	mm(in)		
Wide tube			mm(in)			
Refrigerant tube kit / Accessories			Optional / Hanging wall bracket			
Dimensions & Weight	Unit dimensions		Height	mm	Indoor Unit: 265	Outdoor Unit: 630
			Width	mm	805	830
			Depth	mm	145	305
	package dimensions		Height	mm	208	713
			Width	mm	855	994
			Depth	mm	326	413
	Weight		Net	kg	7.5	61.0
			Shipping	kg	10.0	66.0
	Shipping volume		m ³	0.06	0.29	

DATA SUBJECT TO CHANGE WITHOUT NOTICE.

Remarks: Rating conditions are:

Cooling: Indoor air temperature 27°C DB/19°C WB
 Outdoor air temperature 35°C DB/24°C WB
 Heating: Indoor air temperature 20°C DB
 Outdoor air temperature 7°C DB/6°C WB

2-2. Major Component Specifications

Indoor Unit **SAP-KM97GHS5A or SAP-KM97GHS5A/E**

Controller PCB	Part No.		POW-KM97GHS	
	Controls		Microprocessor	
	Control circuit fuse		250 V – 3.15 A	
Remote Control Unit			RCS-7MHS1E	
Fan & Fan Motor	Type		Cross-flow	
	Number ... Dia. and length		1 ... ø70 / L598	
	Fan motor model ... Number		KFV2Q-11B5P ... 1	
	No. of poles ... rpm (230 V, High)		2 ... 1,900	
	Nominal output		10 W	
	Coil resistance (Ambient temp. 20°C)		Ω	
			WHT – BRN : 385.3 WHT – VLT : 113.6 VLT – ORG : 37.4 ORG – YEL : 87.8 YEL – PNK : 95.8	
	Safety devices	Type	Internal thermal fuse	
		Operating temp.	Open	°C
			Close	—
Run capacitor			μF	
			VAC	
		1.0	440	
Flap Motor	Type		Stepping motor	
	Model		MP24GA1	
	Rating		DC 12 V	
	Coil resistance (Ambient temp. 25°C)		Ω	
		WHT – BLU (respectively 4 wires) : 380 ± 7%		
Heat Exch. Coil	Coil		Aluminum plate fin / Copper tube	
	Rows		2	
	Fin pitch		mm	
	Face area		m ²	
		1.4	0.126	

DATA SUBJECT TO CHANGE WITHOUT NOTICE.

outdoor Unit

SAP-MC1827GH5

Controller PCB		POW-C186CMH			
Control circuit fuse		250 V- 3 A			
Compressor	Type		Rotary (Hermetic)		
	Compressor model ... Number		C-R95H5K ... 2 / 80696745-S ... 2		
	Nominal output	W	950 x 2		
	Compressor oil ... Amount		SUNISO 4GSD-T ... 650 x 2		
	Coil resistance (Ambient temp. 25°C)		C - R : 2.88 C - S : 6.87		
	Safety devices	Type		External (OLR 1, 3) External (OLR 2, 4)	
		Overload relay ... Number		MRA99089-9201 ... 2 CS-7C115 ... 2	
		Operating temp.	Open	°C	145 ± 5 115 ± 3
			Close	°C	69 ± 11 95 ± 5
	Operating amp. (Ambient temp. 25°C)		Trip in 6 to 16 sec. at 16.5 A —		
Run capacitor ... Number		µF	22.5 ... 2		
		VAC	400 ... 2		
Fan & Fan Motor	Type		Propeller		
	Number ... Dia.		mm	1 ... ø400	
	Fan motor model ... Number		SG6-51B5P ... 1		
	No. of poles ... rpm (230 V,High)		6 ... 910		
	Nominal output		W	50	
	Coil resistance (Ambient temp. 20°C)		Ω	WHT - BRN : 92.1 WHT - PNK: 196.4	
	Safety devices	Type		Internal protector	
		Operating temp.	Open	°C	130 ± 8
	Close				Automatic reclosing
	Run capacitor		µF	2.0	
		VAC	480		
Heat Exch. Coil	Coil		Aluminum plate fin / Copper tube		
	Rows		2		
	Fin pitch		mm	1.6	
	Face area		m ²	0.453	
External Finish		Acrylic baked-on enamel finish			

DATA SUBJECT TO CHANGE WITHOUT NOTICE.

2-3. Other Component Specifications

Indoor Unit **SAP-KM97GHS5A** **SAP-KM97GHS5A/E**

Transformer (TR)		ATR-J125	
Rating	Primary	AC 230V, 50Hz	
	Secondary	19V, 0.631A	
	Capacity	12VA	
Coil resistance	Ω (at 21°C)	Primary (WHT – WHT):	205 \pm 10%
		Secondary (BRN – BRN):	1.5 \pm 10%
Thermal cut-off temp.		150°C	

Thermistor (Coil sensor TH1)		PBC-41E-S4			
Resistance	k Ω	-20°C	40.1 \pm 5%	20°C	6.5 \pm 5%
		-10°C	24.4 \pm 5%	30°C	4.4 \pm 5%
		0°C	15.3 \pm 5%	40°C	3.0 \pm 5%
		10°C	9.9 \pm 5%	50°C	2.1 \pm 5%

Thermistor (Room sensor TH2)		DTN-TKS106E	
Resistance	k Ω	25°C	5.0 \pm 3%

Outdoor Unit **SAP-MC1827GH5**

Power Relay (PRA, PRB)		DFU24D1-F (M)	
Coil rating		DC 24V	
Coil resistance	Ω (at 20°C)	650 \pm 10%	
Contact rating		AC 250V, 20A	

Termistor (Coil sensor)		PBC-41E-S15			
Resistance	k Ω	-10°C	23.7 \pm 5%	25°C	5.3 \pm 5%
		0°C	15.0 \pm 5%	30°C	4.4 \pm 5%
		10°C	9.7 \pm 5%	40°C	3.1 \pm 5%
		20°C	6.5 \pm 5%		

Solenoid Coil (4-way Valve SCA, SCB)		CHV-01Ai038A1 (Coil), CHV-0101 (Valve)	
Coil rating		AC 230V, 50Hz, 5W	
Coil resistance	Ω (at 20°C)	1,408 \pm 7%	

3. DIMENSIONAL DATA

Outdoor Unit **SAP-KM97GHS5A**
 SAP-KM97GHS5A/E

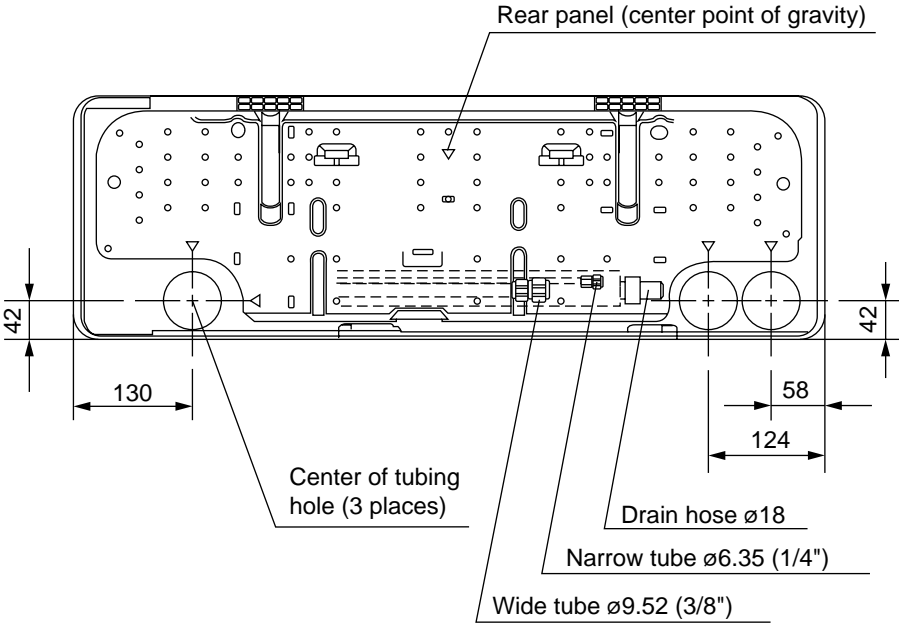
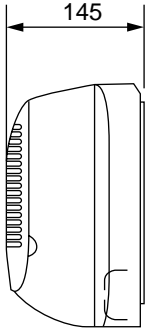
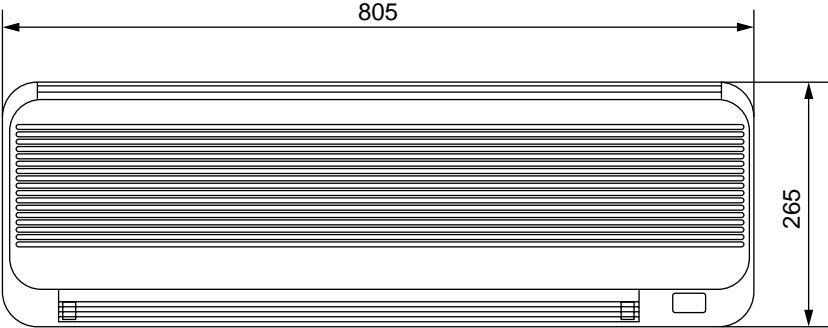

Remote control unit

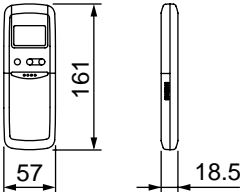

Dimensions : mm

Outdoor Unit

SAP-MC1827GH5

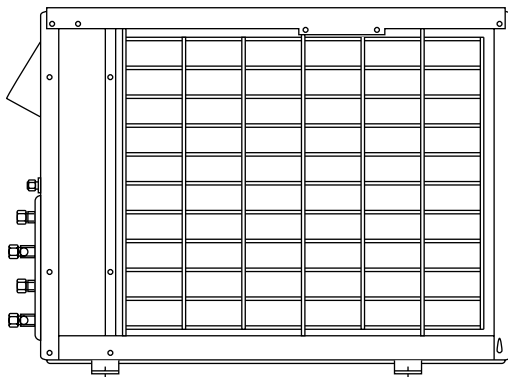
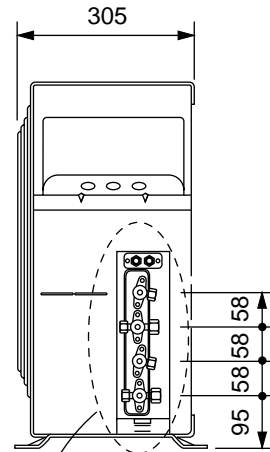
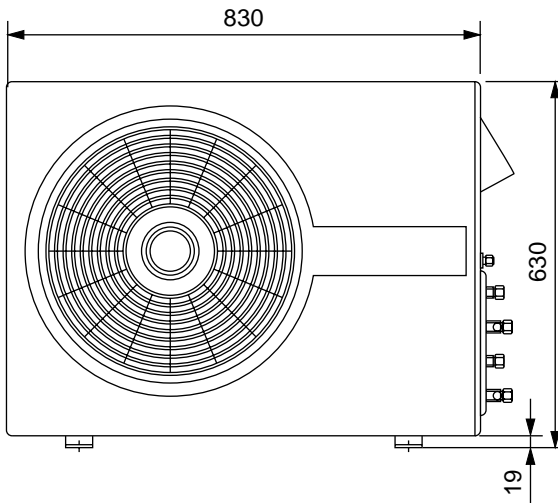
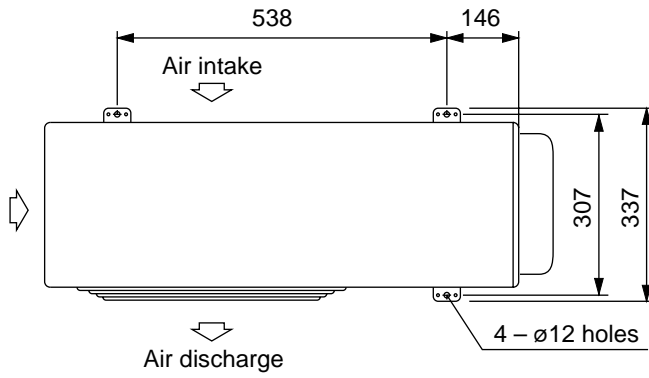

Magnified illustration

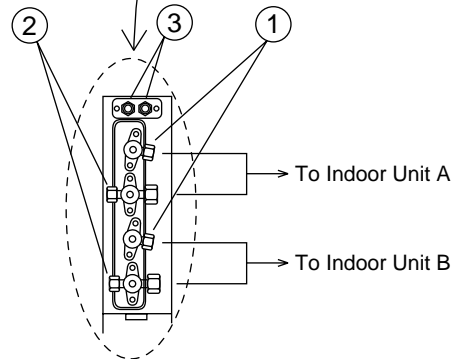

- ① Narrow tube service valve
ø6.35(1/4")
- ② Wide tube service valve
ø9.52(3/8")
- ③ Check Port

Dimensions : mm

4. COOLING CAPACITY

Indoor Unit **SAP-KM97GHS5A(x1) or SAP-KM97GHS5A/E(x1)**

Outdoor Unit **SAP-MC1827GH5**

230 V Single phase 50 Hz

RATING CAPACITY : 2.60 kW			AIR FLOW RATE : 450 CMH					
EVAPORATOR		CONDENSER						
ENT. TEMP. °C		OUTDOOR AMBIENT TEMP °C						
W. B	D. B		20	25	30	35	40	45
15		TC	2.62	2.51	2.39	2.28	2.14	1.97
		CM	0.68	0.73	0.78	0.84	0.95	1.07
	21	SHC	1.92	1.86	1.81	1.76	1.69	1.62
	23	SHC	2.22	2.16	2.11	2.06	2.00	1.92
	25	SHC	2.52	2.47	2.39	2.28	2.14	1.97
	27	SHC	2.62	2.51	2.39	2.28	2.14	1.97
	29	SHC	2.62	2.51	2.39	2.28	2.14	1.97
	31	SHC	2.62	2.51	2.39	2.28	2.14	1.97
17		TC	2.81	2.69	2.57	2.44	2.30	2.11
		CM	0.70	0.75	0.80	0.86	0.98	1.09
	21	SHC	1.60	1.55	1.50	1.44	1.38	1.31
	23	SHC	1.90	1.85	1.80	1.74	1.68	1.61
	25	SHC	2.21	2.15	2.10	2.05	1.98	1.91
	27	SHC	2.51	2.45	2.40	2.35	2.29	2.11
	29	SHC	2.81	2.69	2.57	2.44	2.30	2.11
	31	SHC	2.81	2.69	2.57	2.44	2.30	2.11
19		TC	2.99	2.86	2.73	# 2.60	2.44	2.25
		CM	0.72	0.77	0.83	0.89	1.01	1.12
	21	SHC	1.28	1.23	1.17	1.12	1.06	0.99
	23	SHC	1.58	1.53	1.47	1.42	1.36	1.29
	25	SHC	1.88	1.83	1.78	1.72	1.66	1.59
	27	SHC	2.18	2.13	2.08	2.03	1.97	1.89
	29	SHC	2.48	2.43	2.38	2.33	2.27	2.19
	31	SHC	2.79	2.73	2.68	2.60	2.44	2.25
21		TC	3.17	3.03	2.89	2.76	2.59	2.38
		CM	0.74	0.80	0.85	0.91	1.03	1.15
	23	SHC	1.25	1.20	1.15	1.10	1.04	0.97
	25	SHC	1.56	1.50	1.45	1.40	1.34	1.27
	27	SHC	1.86	1.81	1.75	1.70	1.64	1.57
	29	SHC	2.16	2.11	2.06	2.01	1.95	1.87
	31	SHC	2.46	2.41	2.36	2.31	2.25	2.17
23		TC	3.36	3.22	3.07	2.89	2.71	2.52
		CM	0.75	0.82	0.87	0.94	1.06	1.18
	25	SHC	1.22	1.17	1.11	1.06	0.99	0.93
	27	SHC	1.52	1.47	1.41	1.36	1.30	1.23
	29	SHC	1.82	1.77	1.72	1.66	1.60	1.54
	31	SHC	2.12	2.07	2.02	1.96	1.90	1.84

TC : Total Cooling Capacity (kW)

SHC : Sensible Heat Capacity (kW)

CM : Compressor Input (kW)

Rating conditions(#MARK) are

: Outdoor Ambient Temp. 35°C D.B.

: Indoor Unit Entering Air Temp. 27°C D.B./19°C W.B.

5. HEATING CAPACITY

Indoor Unit **SAP-KM97GHS5A or SAP-KM97GHS5A/E**
Outdoor Unit **SAP-MC1827GH5**

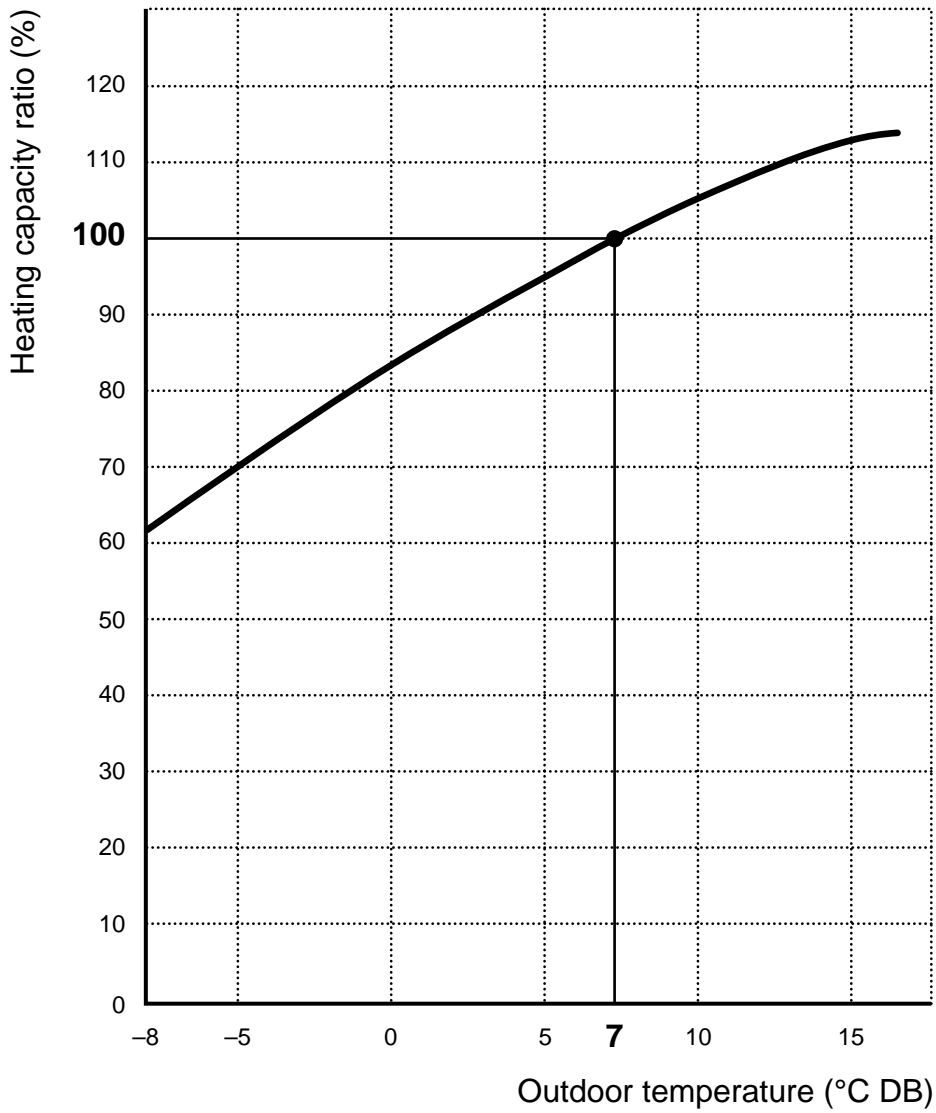

NOTE

- 1) ●... Point of Rating condition
Black dot in the chart indicate the following rating condition.
Indoor : 20°C DB
Outdoor : 7°C DB / 6°C WB
- 2) Above characteristics indicate instantaneous operation, which does not take into consideration defrost operation.
- 3) Fan speed : High

6. AIR THROW DISTANCE CHART

Indoor Unit **SAP-KM97GHS5A**
 SAP-KM97GHS5A /E

Cooling

Room air temp. : 27°C
 Fan speed : High

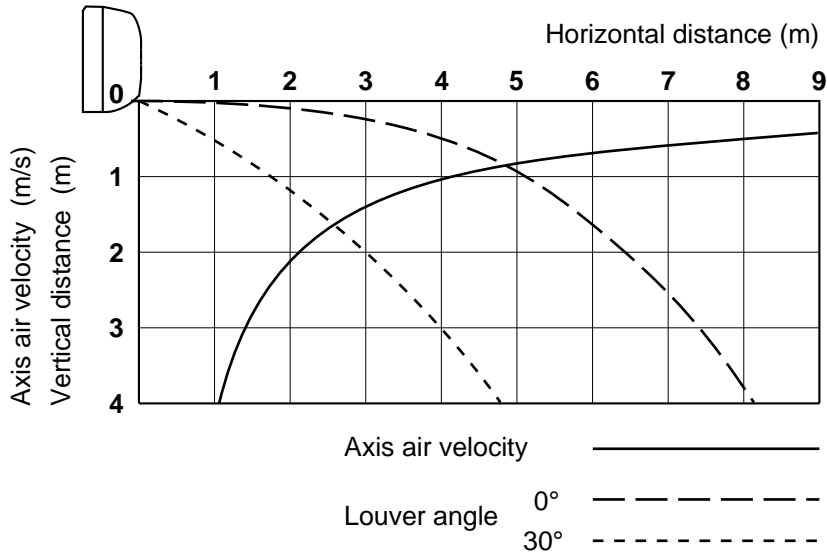

Heating

Room air temp. : 20°C
 Fan speed : High

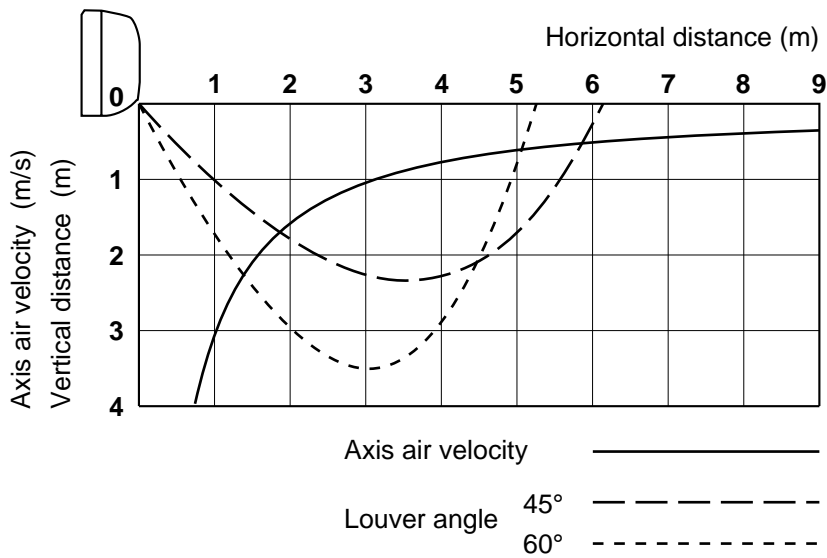





7. REFRIGERANT FLOW DIAGRAM

Indoor Unit **SAP-KM97GHS5A or SAP-KM97GHS5A/E**

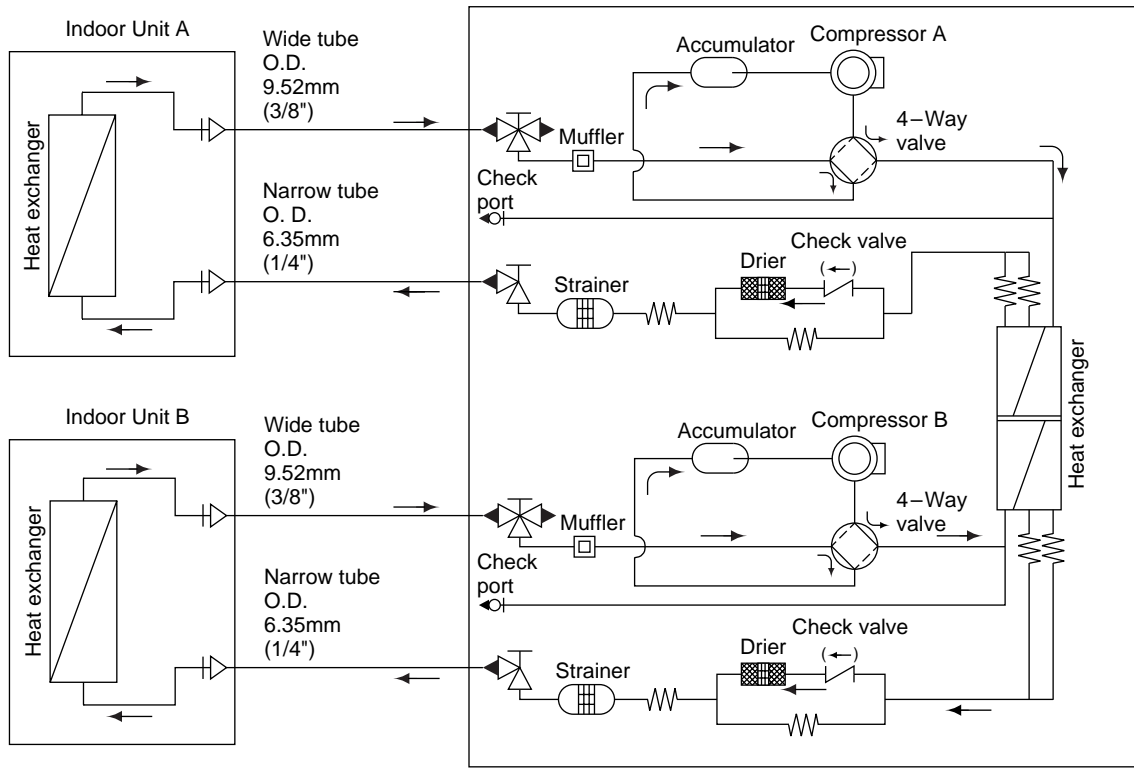
Outdoor Unit **SAP-MC1827GH5**

Cooling cycle



-  Capillary tube
-  Wide Tube Service valve
-  Narrow Tube Service valve

Heating cycle

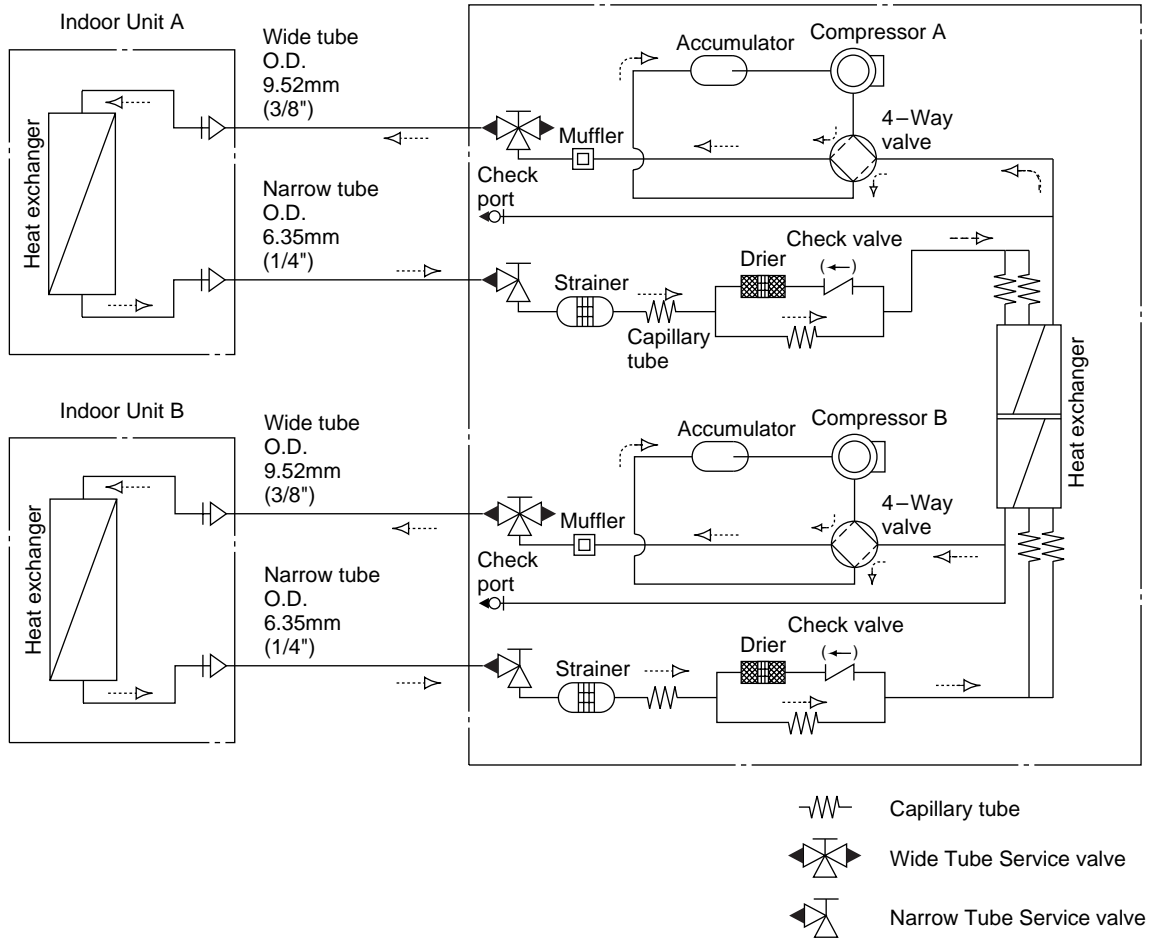

Insulation of Refrigerant Tubing

IMPORTANT

To prevent heat loss and wet floors due to dripping of condensation water, **both the wide and narrow tubes must be well insulated with proper insulation material**. The thickness of the insulation should be a min. 8 mm.

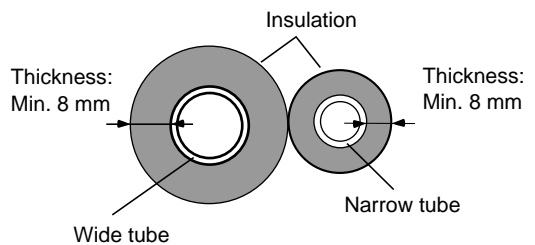

CAUTION

After a tube has been insulated, never try to bend it into a narrow curve because it can cause the tube to break or crack.

8. ELECTRICAL DATA

8-1. Electrical Characteristics

NOTE

The values in the table below indicate the sum of indoor and outdoor units which are in running condition.

Indoor Unit **SAP-KM97GHS5A or SAP-KM97GHS5A/E**
 Outdoor Unit **SAP-MC1827GH5**

Cooling

230V Single phase 50 Hz

Number of indoor unit		1 - Unit (Either A or B)	2 - Units (Both A and B)
Rating Conditions	Running amp. A	4.6	9.3
	Power input kW	1.01	2.08
Full Load Conditions	Running amp. A	6.0	12.2
	Power input kW	1.30	2.72

Heating

230V Single phase 50 Hz

Number of indoor unit		1 - Unit (Either A or B)	2 - Units (Both A and B)
Rating Conditions	Running amp. A	5.0	9.0
	Power input kW	1.09	1.98
Full Load Conditions	Running amp. A	6.5	11.8
	Power input kW	1.41	2.58

Cooling

Rating Conditions: Indoor Air Temperature 27°C DB / 19°C WB
 Outdoor Air Temperature 35°C DB

Full Load Conditions: Indoor Air Temperature 32°C DB / 23°C WB
 Outdoor Air Temperature 43°C DB

Heating

Rating Conditions: Indoor Air Temperature 20°C DB
 Outdoor Air Temperature 7°C DB / 6°C WB

Full Load Conditions: Indoor Air Temperature 27°C DB
 Outdoor Air Temperature 24°C DB / 18°C WB

8-2. Electric Wiring Diagram

Indoor Unit

SAP-KM97GHS5A

SAP-KM97GHS5A/E

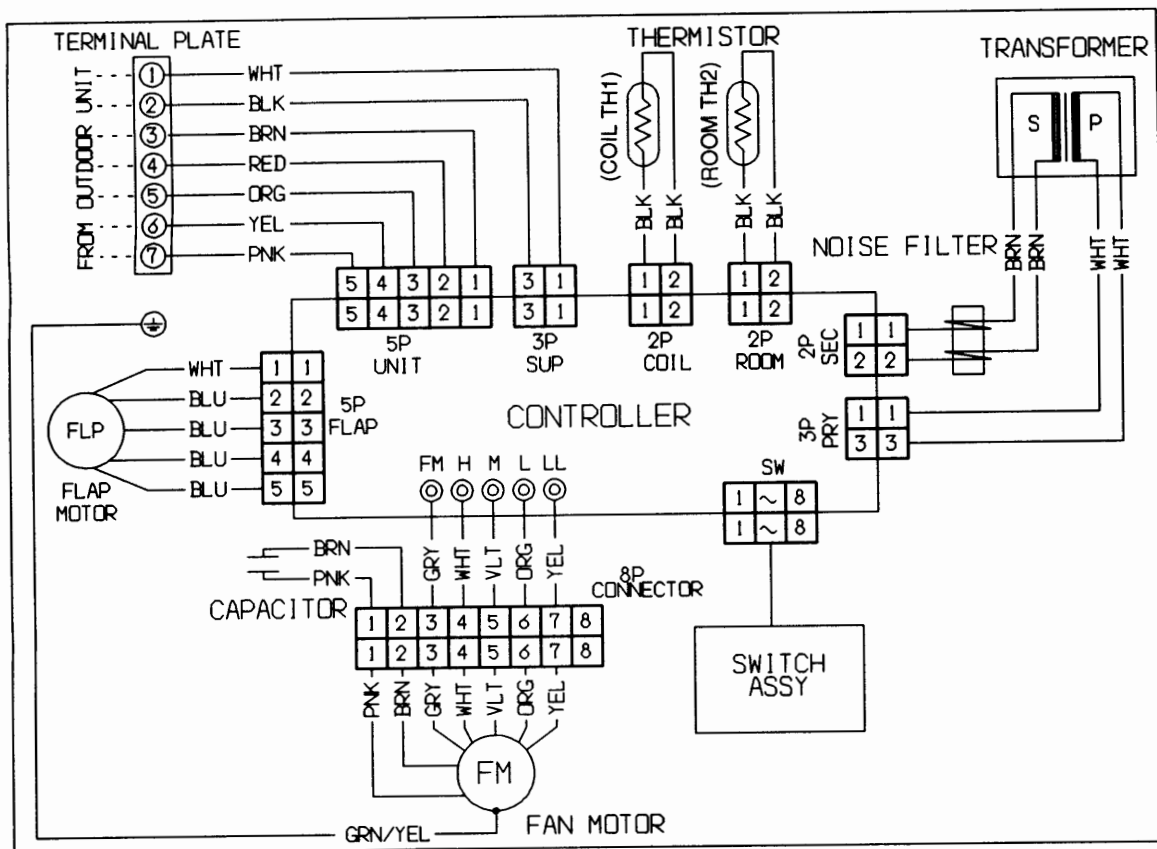

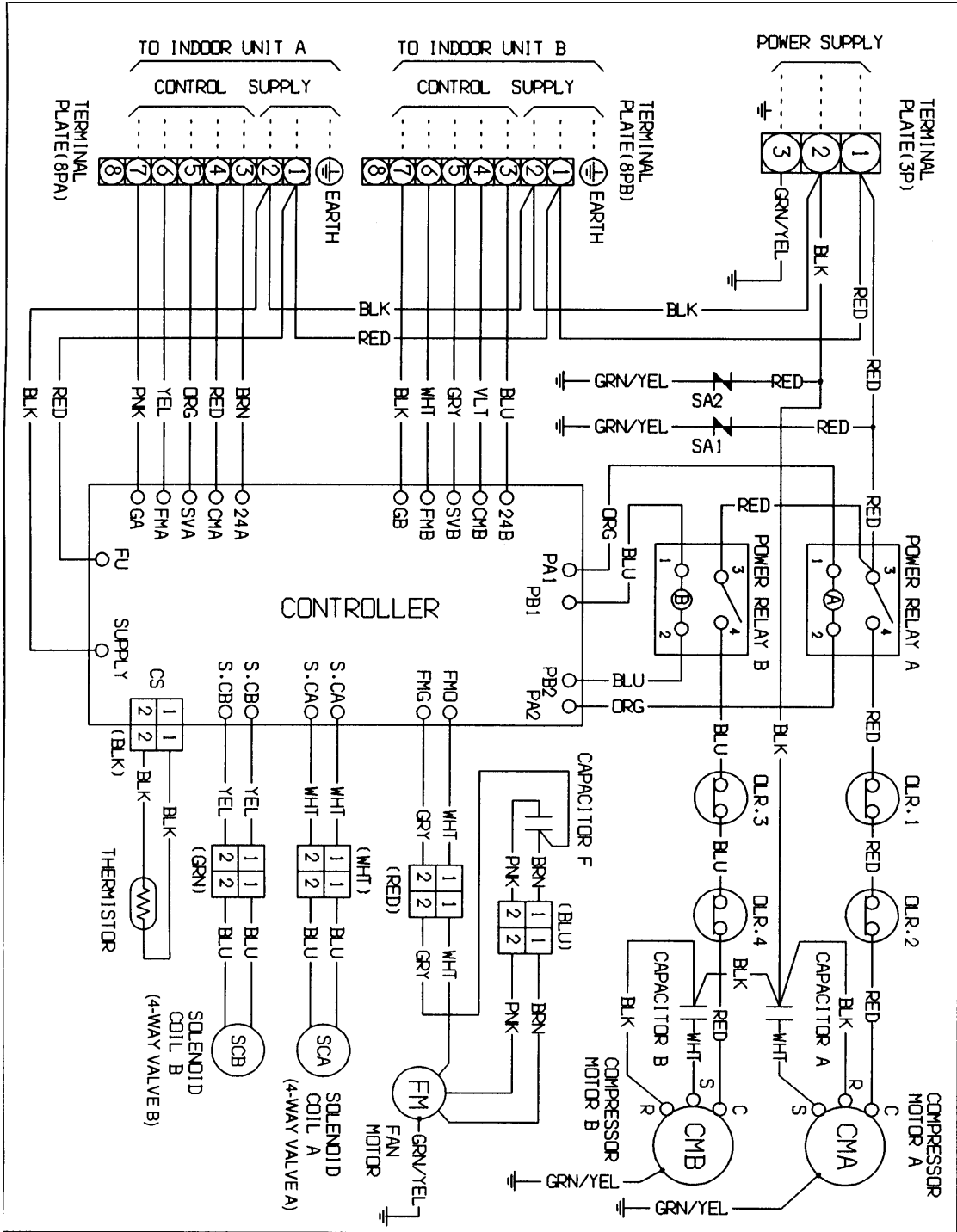

9. INSTALLATION INSTRUCTIONS

9-1. Installation Site Selection

Maximum Allowable Tubing Length(L)and Elevation Difference(H).

The Multi-Split System outdoor unit should be installed as close to the indoor units as possible. Maximum allowable length of the refrigerant tubing and elevation difference between outdoor and indoor units are shown in Table 1.

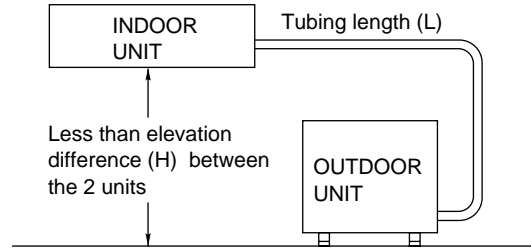

Fig. 1

Table 1

Combination		Max allowable tubing length at shipment.(m)	Limit of tubing length(L). (m)	Limit of elevation difference(H). (m)	Required amount of additional refrigerant*(g/m)
Outdoor unit	Indoor unit				
MC1827	KM97	7.5	15	7	15
	KM97				

* If total tubing length becomes 7.5 to 15 m (max.),charge additional refrigerant (R22) by 15 g/m. No additional charge of compressor oil is necessary.

Indoor Unit



WARNING

To prevent abnormal heat generation and the possibility of fire, don't place obstacles, enclosures and grills in front of or surrounding the air conditioner in a way that may block air flow.

● Wall-Mounted Type

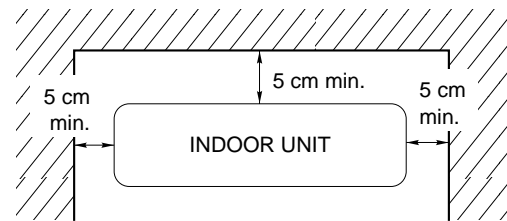

Front View
Fig.2a

AVOID:

- direct sunlight.
- nearby heat sources that may affect performance of the unit.
- areas where leakage of flammable gas may be expected.
- places where large amounts of oil mist exist.

DO:

- select an appropriate position from which every corner of the room can be uniformly air-conditioned. (High on a wall is best)
- select a location that will hold the weight of the unit.
- select a location where tubing and drain pipe have the shortest run to the outside.
- allow room for operation and maintenance as well as unrestricted air flow around the unit. (Fig. 2a)



CAUTION

For stable operation of the air conditioner, do not install wall-mounted type indoor units under 1.5m from floor level.

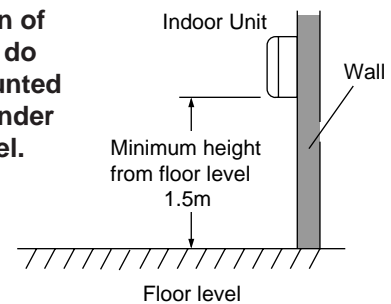

Fig. 2b

Outdoor Unit

AVOID:

- heat sources, exhaust fans, etc. (Fig. 3)
- damp, humid or uneven locations.

DO:

- choose a place as cool as possible.
- choose a place that is well ventilated.
- allow enough room around the unit for air intake/exhaust and possible maintenance. (Figs. 4a and 4c)
- provide a solid base (concrete block, 10 × 40 cm beams or equal), a minimum of 10 cm above ground level to reduce humidity and protect the unit against possible water damage and decreased service life. (Fig. 5a)
- use lug bolts or equal to bolt down unit, reducing vibration and noise.

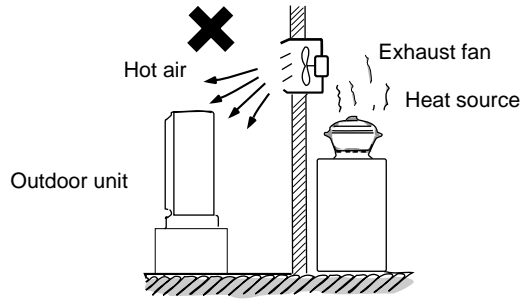
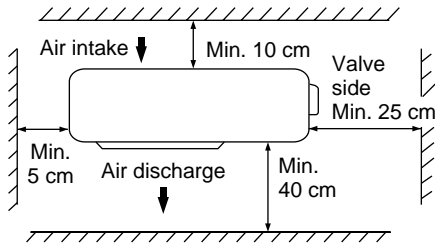
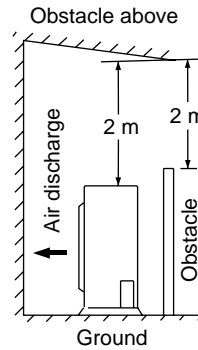

Fig. 3

Required space around the unit.



**Top View
Fig. 4a**



**Side View
Fig. 4c**

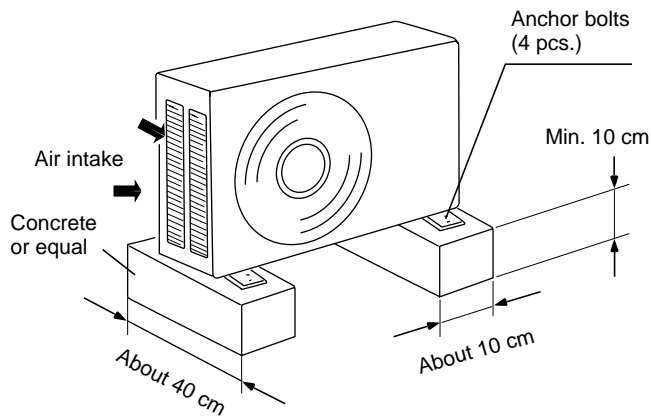

Fig. 5a

9-2. Remote Control Unit Installation Position

The remote control unit can be operated from either a non-fixed position or a wall-mounted position.

To ensure that the air conditioner operates correctly, do not install the remote control unit in the following places:

- In direct sunlight
- Behind a curtain or other place where it is covered
- More than 8 m away from the air conditioner
- In the path of the air conditioner's airstream
- Where it may become extremely hot or cold
- Where it may be subject to electrical or magnetic interference

Mounting on a Wall

a) Removable mounting

- 1) Momentarily hold the remote control unit at the desired mounting position.
- 2) Confirm that the air conditioner responds correctly when you press keys on the remote control from that position.
- 3) After confirming correct operation, use a screwdriver to screw the supplied special mounting screw into the wall. (Fig.6a)
- 4) Hang the remote control unit from the mounting screw.

b) Non-removable mounting

- 1) Momentarily hold the remote control unit at the desired mounting position.
- 2) Confirm that the air conditioner responds correctly when you press keys on the remote control from that position.
- 3) After confirming correct operation, use a screwdriver to screw the supplied special mounting screw into the wall. (Fig.6a)
- 4) Remove the remote control cover by sliding it downward.
- 5) Remove the batteries of the remote control unit.
- 6) Use a screwdriver to screw the remote control unit securing screw into the wall through the hole in the battery compartment. (Fig.6b)
- 7) Replace the batteries.
- 8) Again confirm that the remote control unit operates correctly.

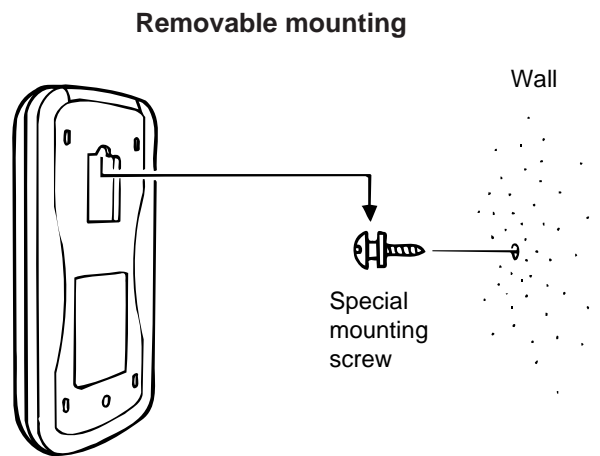

Fig.6a

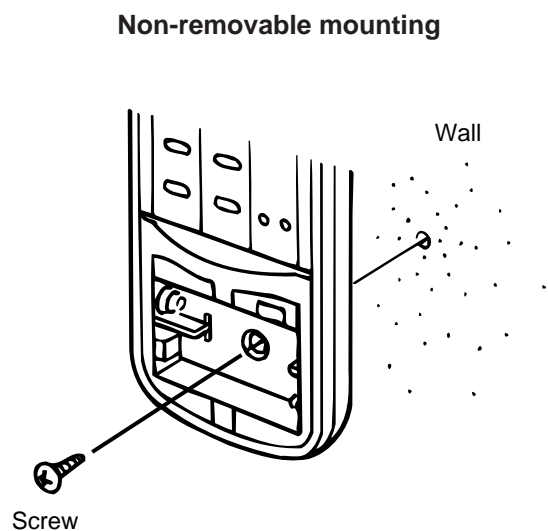

Fig.6b

9-3. Recommended Wire Length and Diameter

Regulations on wiring diameter differ from locality to locality. For field wiring requirements, please refer to your local electrical codes. Carefully observe these regulations when carrying out the installation. Table 2 lists recommended wire lengths and size for power supply systems.

NOTE

Refer to the WIRING SYSTEM DIAGRAM for the meaning of "A", "B" and "C" in Table 2.

Table 2

Model	Cross Sectional Area (mm ²)		(A) Power Supply Wiring Length (m)	(B) Power Line Length (m)	(C) Control Line	Fuse or Circuit Capacity
	2 (#14)	3.5 (#12)	2 (#14)	0.75 (#18)		
MC1827	18	27	20	20	20A	

..... AWG (American Wire Gauge)



WARNING

- Be sure to comply with local codes on running the wire from the indoor unit to the outdoor unit (size of wire and wiring method, etc.).
- Each wire must be firmly connected.
- No wire should be allowed to touch refrigerant tubing, the compressor, or any moving part.



WARNING

- To avoid the risk of electric shock, each air conditioner unit must be grounded.



CAUTION

- Be sure to connect the power supply line to the outdoor unit as shown in the wiring diagram. The indoor unit draws its power from the outdoor unit.

WIRING SYSTEM DIAGRAM

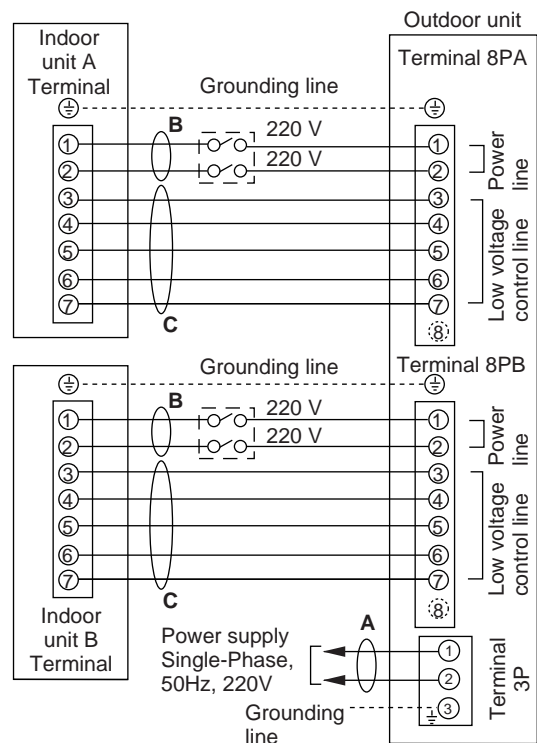

10.FUNCTION

10-1. Room Temperature Control

■ Cooling

- Room temperature control is obtained by cycling the compressor ON and OFF under control of the room temperature sensor in the remote control unit.
- The room temperature (and other information) is transmitted every 3 minutes by the remote control unit to the controller in the indoor unit.

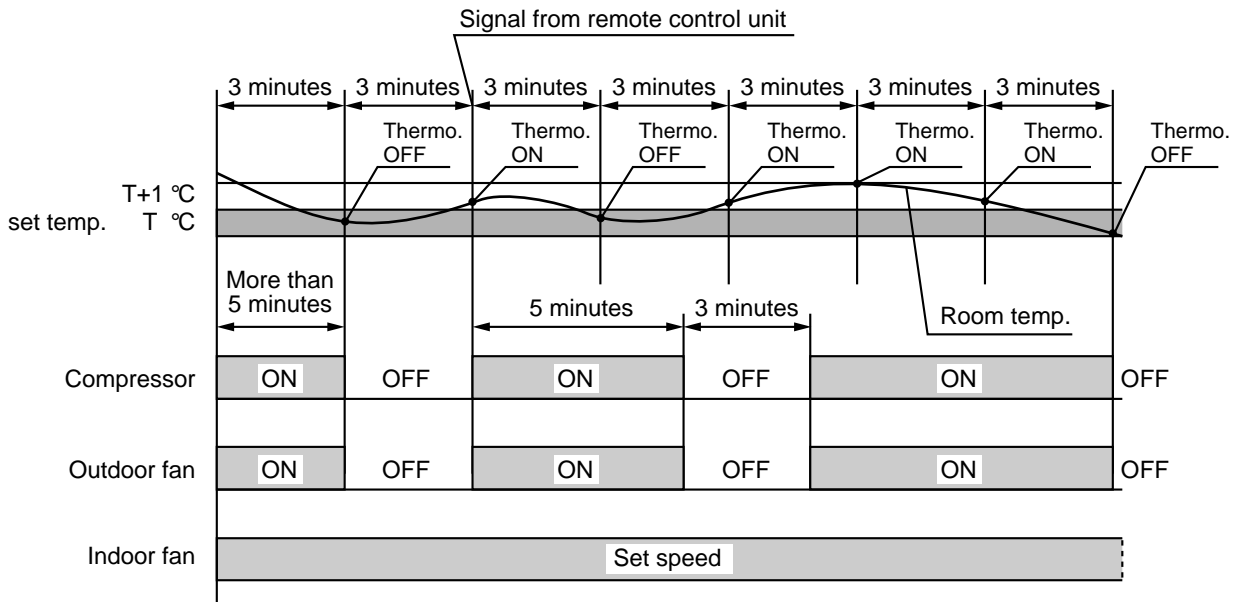

- The control circuit will not attempt to turn the compressor ON until the compressor has been OFF for at least 3 minutes. To protect the compressor from stalling out when trying to start against the high side refrigerant pressure, the control circuit has a built-in automatic time delay to allow the internal pressure to equalize.
- As a protective measure, the control circuit switches the compressor OFF after 5 minutes or more of compressor operation.
- Thermo. ON : When the room temperature is above $T + 1^{\circ}\text{C}$ ($T^{\circ}\text{C}$ is set temperature).
Compressor \rightarrow ON
- Thermo. OFF : When the room temperature is equal to or below set temperature $T^{\circ}\text{C}$.
Compressor \rightarrow OFF

10-2. Dry Operation (Dehumidification)

- Dry operation uses the ability of the cooling cycle to remove moisture from the air, but by running at low level to dehumidify without greatly reducing the room temperature. The air conditioner repeats the cycle of turning ON and OFF automatically as shown in the chart below according to the room temperature.

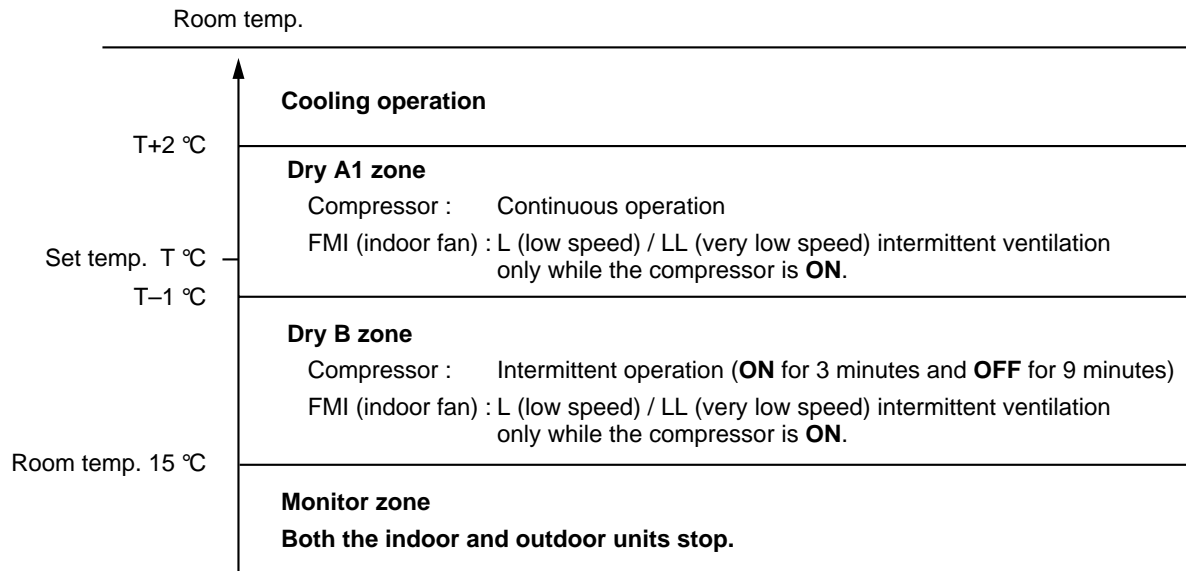

NOTE

- Intermittent ventilation occurs by switching the indoor fan speed between L ↔ LL.
- Dry operation does not occur when the room temperature is under 15°C, which is the monitor zone.
- When the compressor stops, the indoor fan stops as well.

10-3. Freeze Prevention (Cooling)

- This function prevents freezing of the indoor heat exchange coil.
- When the compressor has been running for 10 minutes or more and the temperature of the indoor heat exchange coil falls below -1°C , the control circuit stops the compressor for at least 6 minutes. The compressor does not start again until the temperature rises above 8°C or 6 minutes has elapsed.

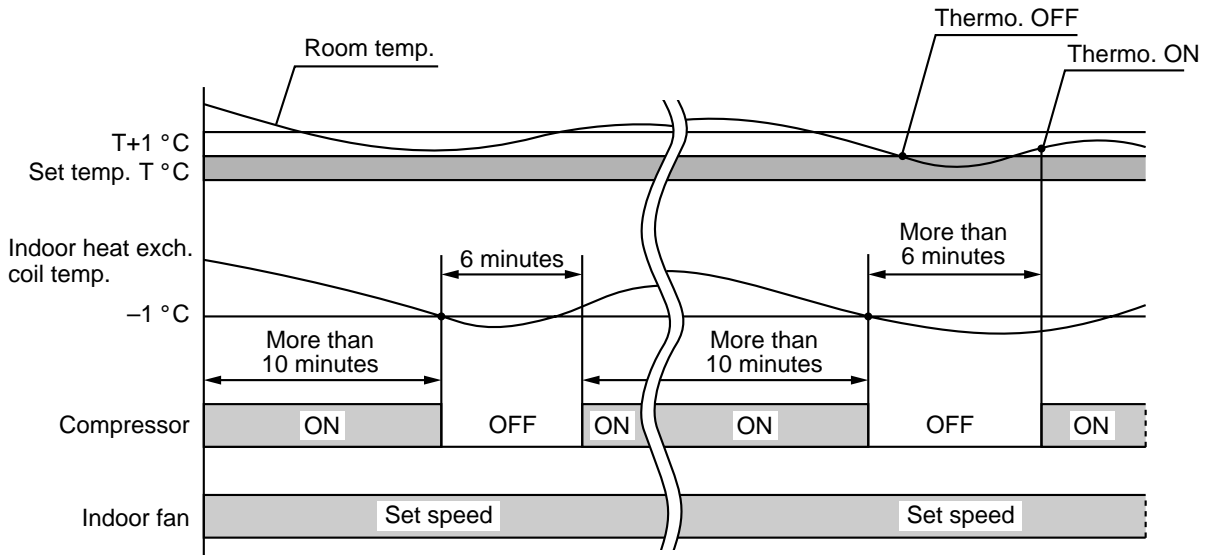

10-4. Overload Prevention (Heating)

- This function prevents overheating of the indoor heat exchange coil.
- When the temperature of the indoor heat exchange coil rises above 54°C , and if the indoor fan is L (low speed), then the fan speed changes from L (low speed) to M (medium speed).
- When the temperature of the indoor heat exchange coil rises above 57°C , the outdoor fan stops.

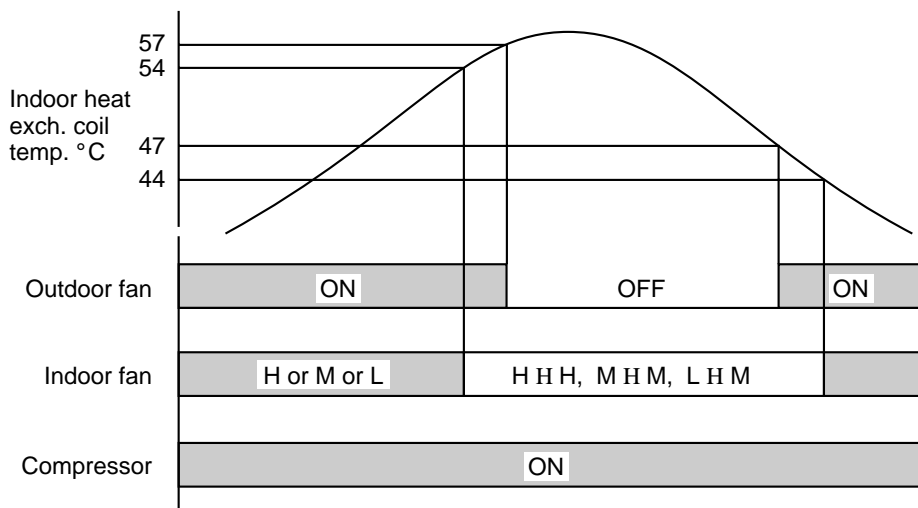

10-5. Cold draft Prevention (Heating)

- This function controls indoor fan speed so a strong draft of cold air will not blow out before the indoor heat exchange coil have sufficiently warmed up.
- STANDBY lamp on front of the indoor unit lights up when the indoor fan speed is either LL or OFF.

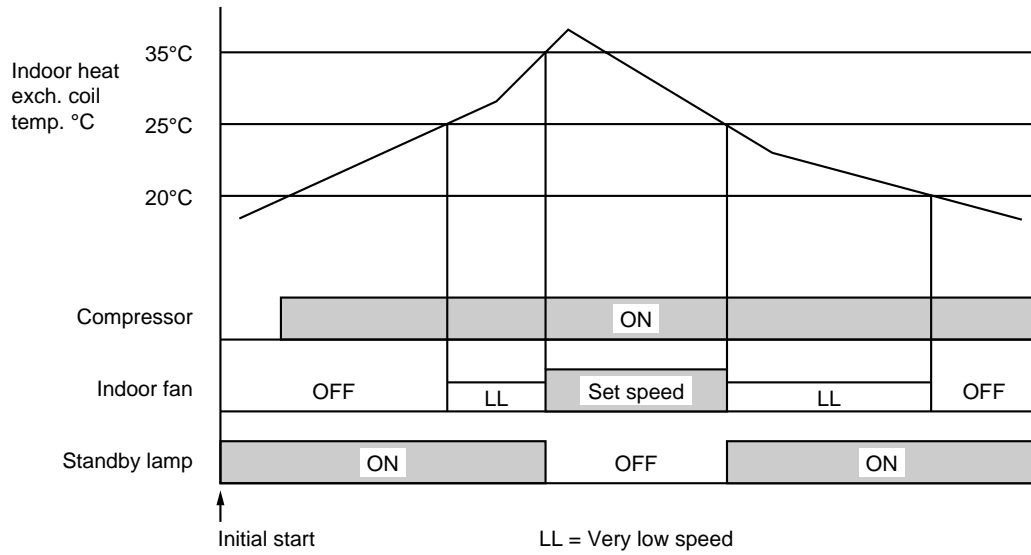

10-6. Defrosting Operation (Heating)

■ Defrosting Flowchart.

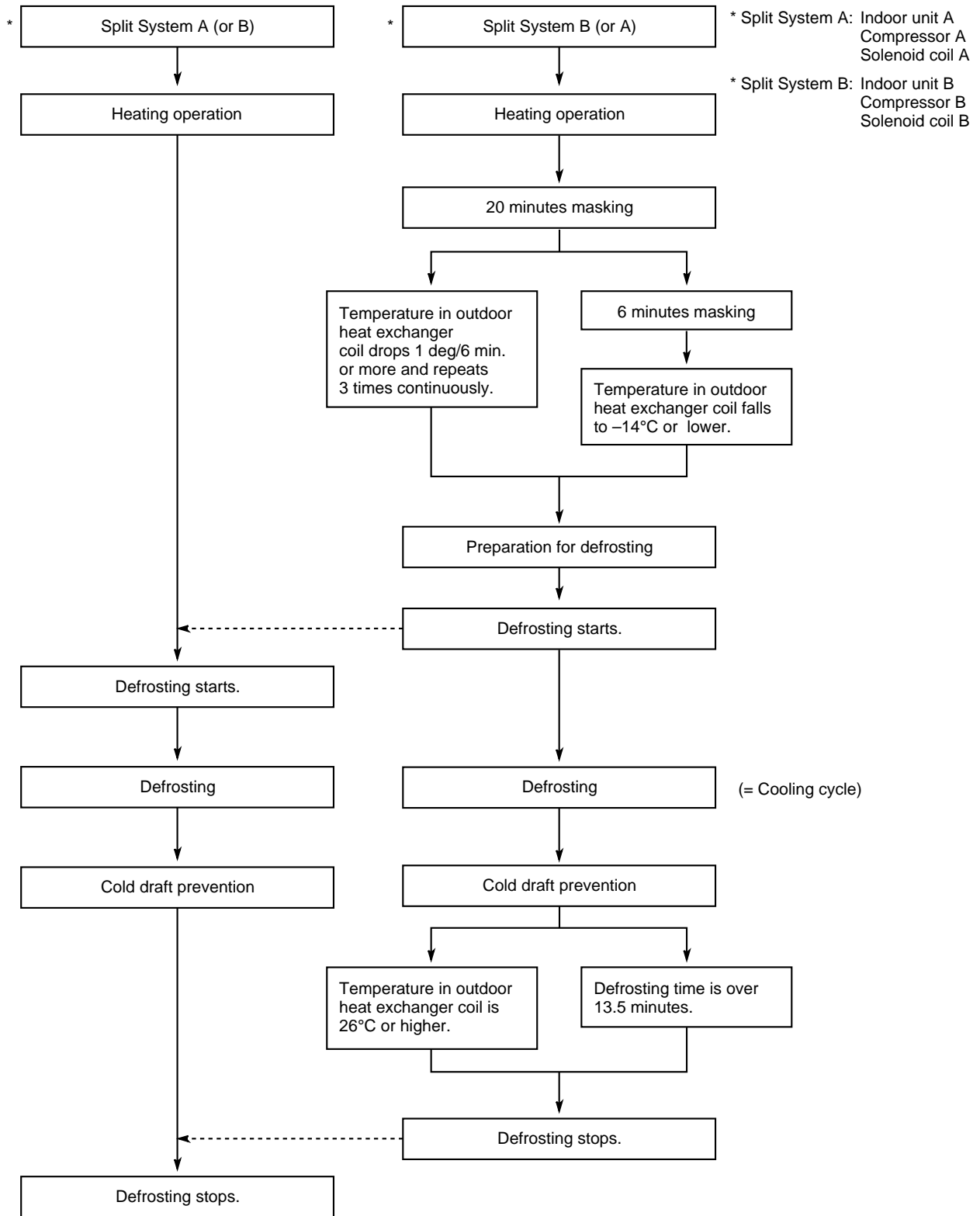

■ Defrosting Mode Timing Chart

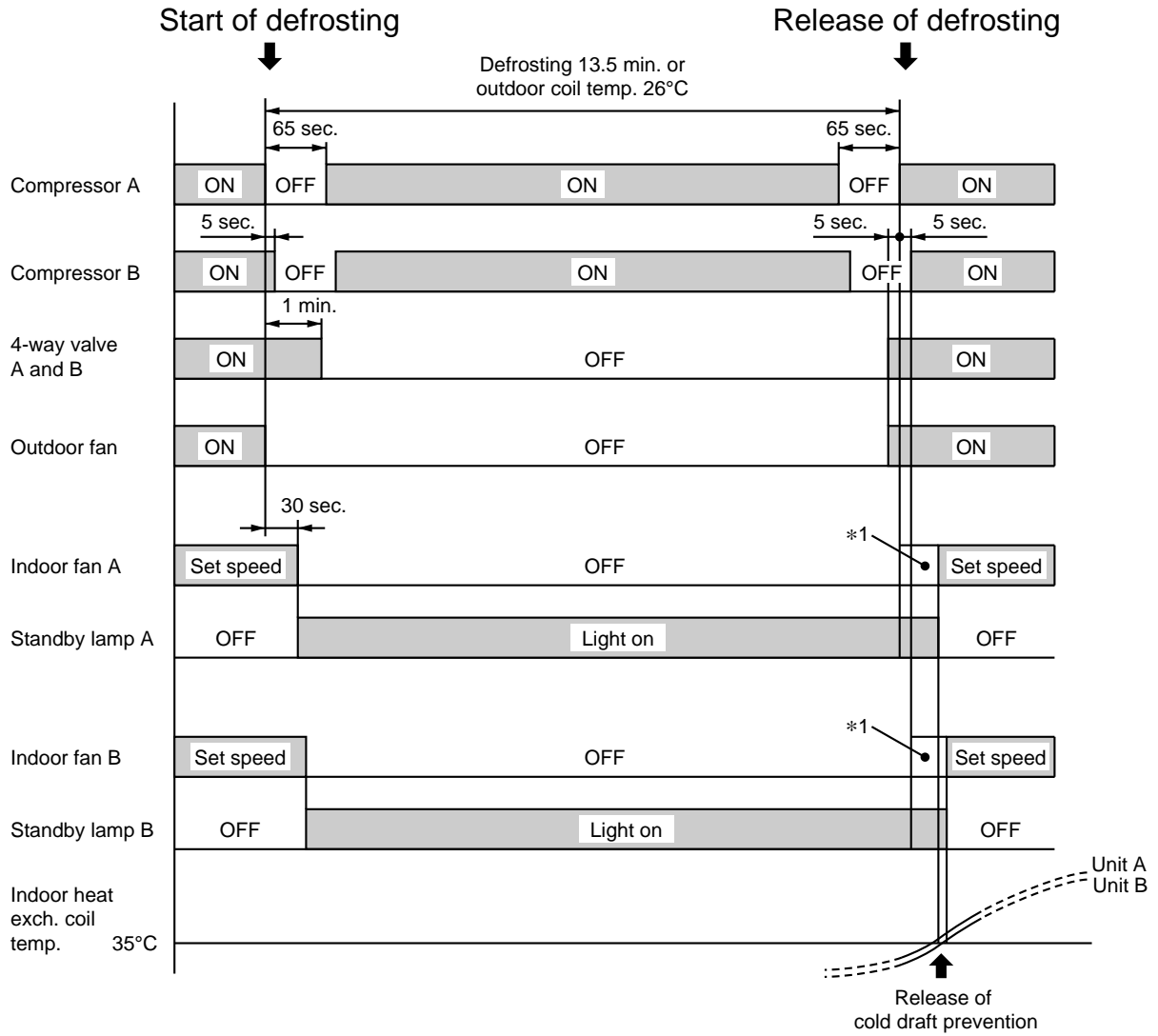

NOTE *1. No LL fan operation during this period.

11.TROUBLESHOOTING

11-1. Check before and after troubleshooting



WARNING

Hazardous voltage can cause **ELECTRIC SHOCK** or **DEATH**. Disconnect power or turn off circuit breaker before you start checking or servicing.

11-1-1. Check power supply wiring.

- Check that power supply wires are correctly connected to terminals **No.1** and **No.2** on the 3p terminal plate in the outdoor unit.

11-1-2. Check inter-unit wiring.

- Check that inter-unit wiring is correctly connected to the indoor unit from the outdoor unit.

11-1-3. Check power supply.

- Check that voltage is in specified range ($\pm 10\%$ of the rating).
- Check that power is being supplied.

11-1-4. Check lead wires and connectors in indoor and outdoor units.

- Check that coating of lead wires is not damaged.
- Check that lead wires and connectors are firmly connected.
- Check that wiring is correct.

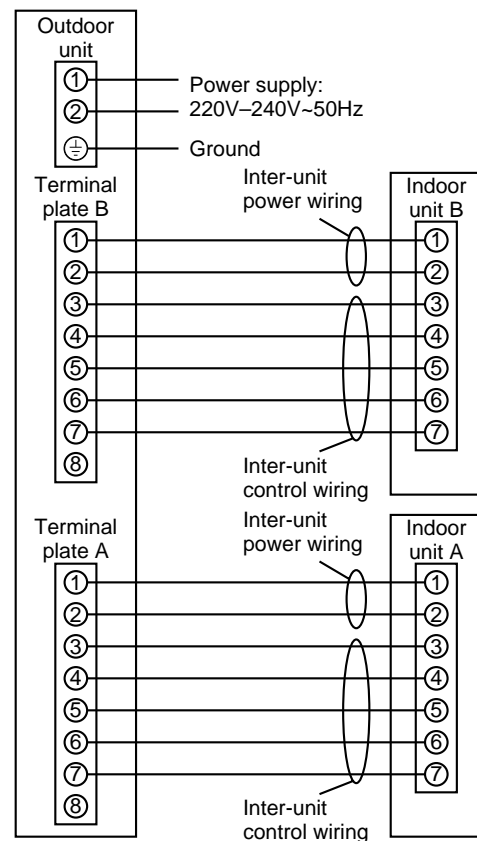

11-2. Air conditioner does not operate.

11-2-1. Circuit breaker trips (or fuse blows).

A. When the circuit breaker is set to ON, it is tripped soon. (Resetting is not possible.)

- There is a possibility of ground fault.
- Check insulation resistance.

If resistance value is $2M\Omega$ or less, insulation is defective ("NO").

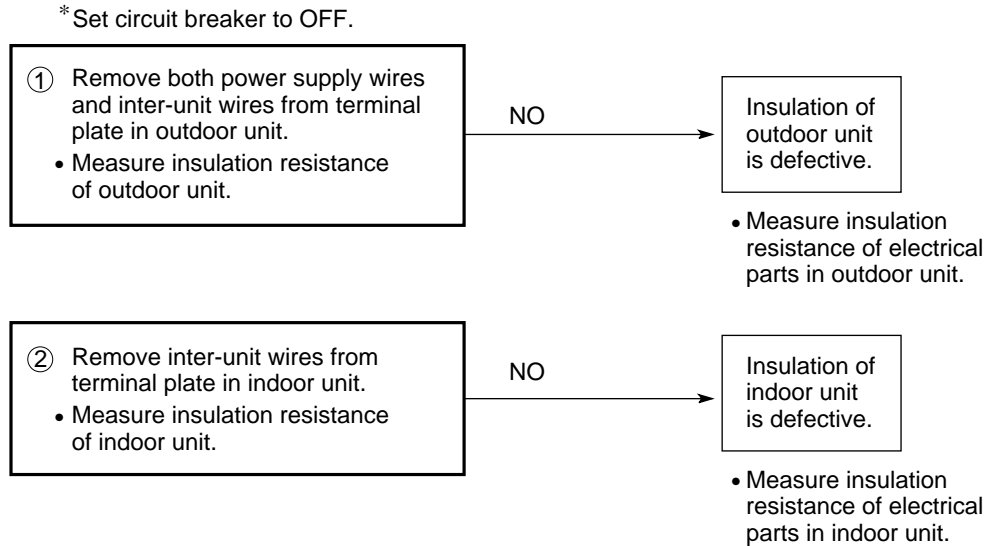

B. Circuit breaker trips in several minutes after turning the air conditioner on.

- There is a possibility of short circuit.

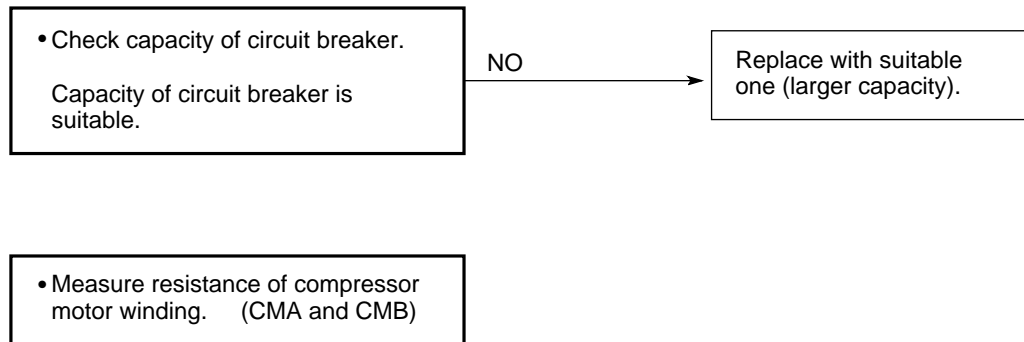

11-2-2. Neither indoor nor outdoor unit runs.

A. Power is not supplied.

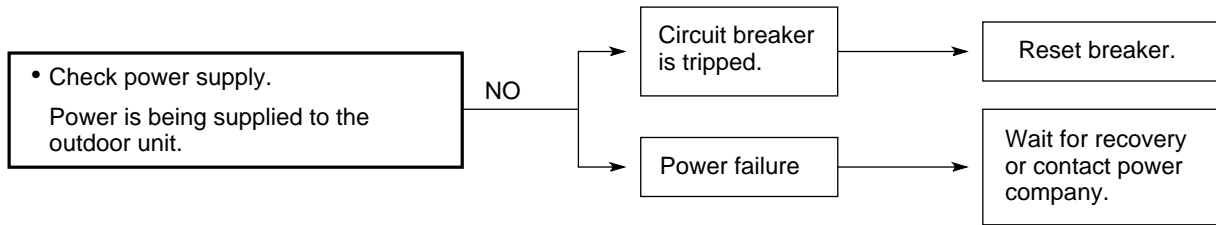

B. Check "OPERATION selector" switch in the indoor unit.

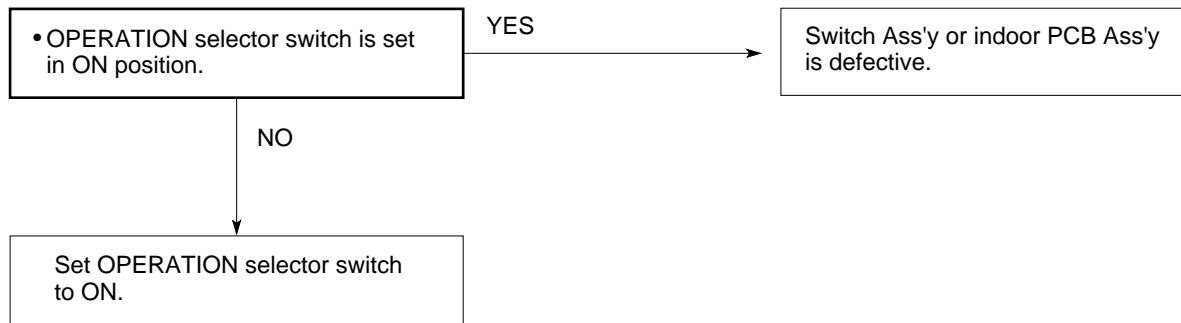

C. Check remote control unit.

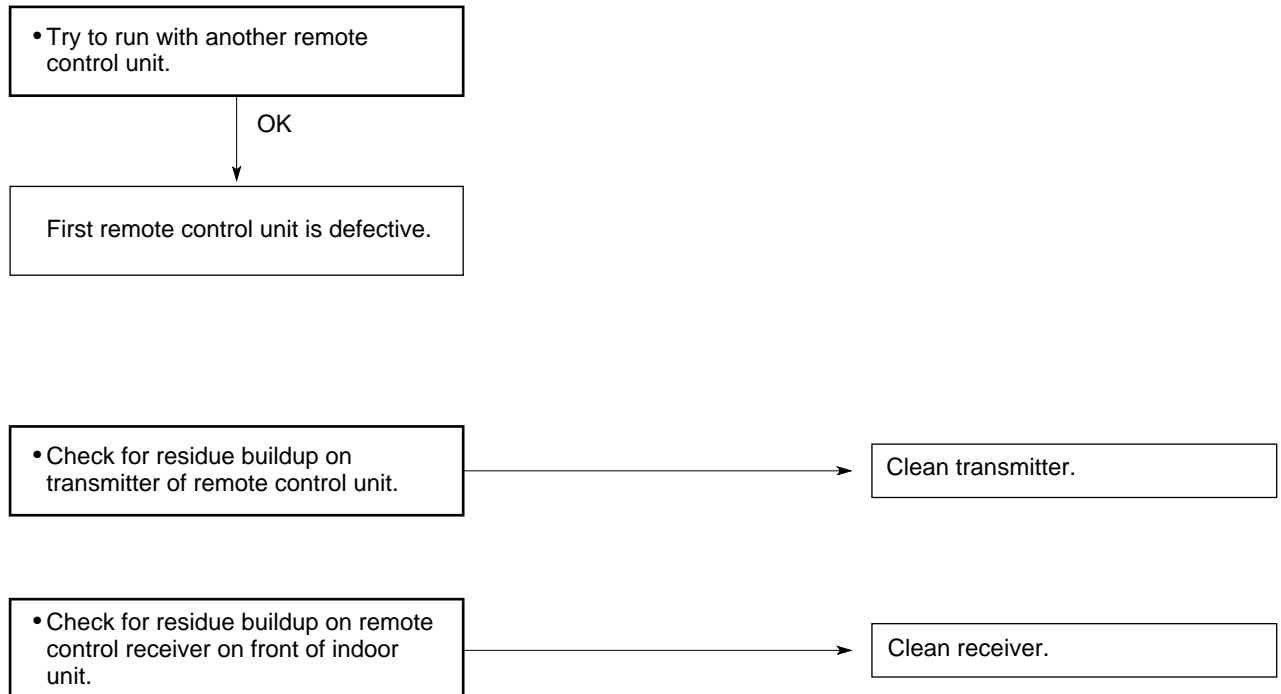

D. Check fuse on the indoor PCB Ass'y.

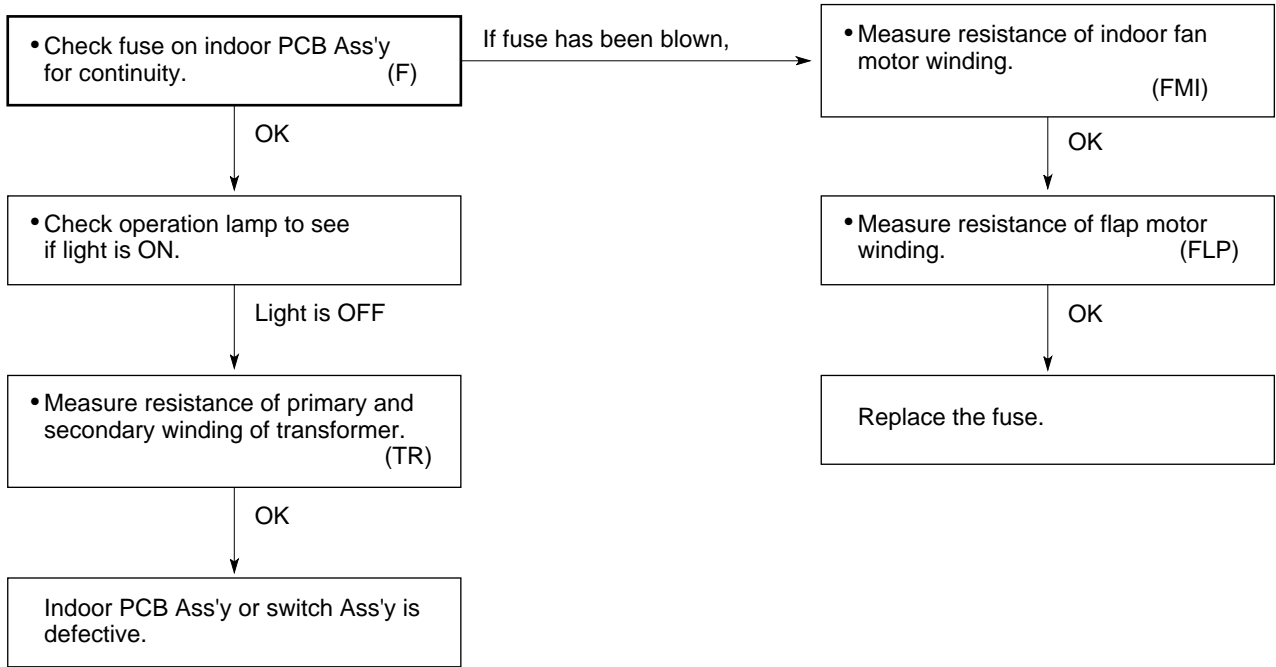

E. Check TIMER SELECT button on the remote control unit.



11-2-3. Only outdoor unit does not run.

A. Check setting temperature.

COOL

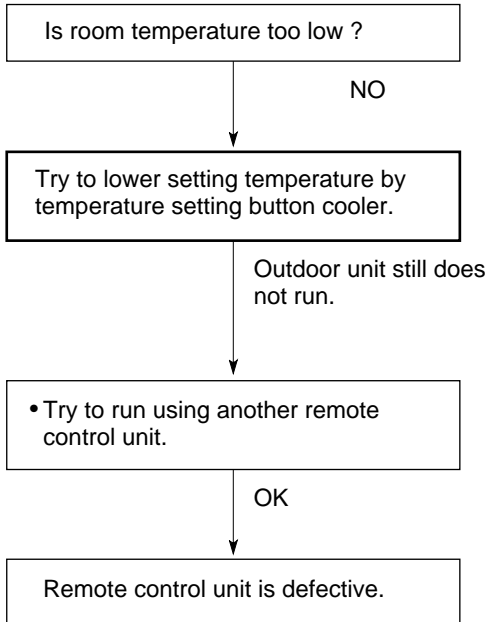

HEAT

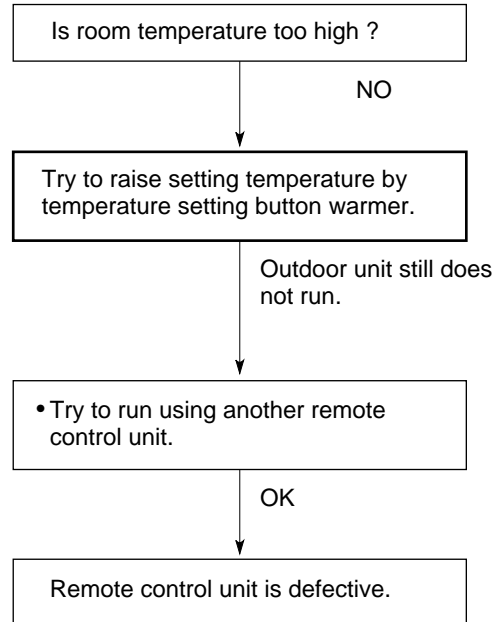

B. Check PCB Ass'y in either indoor or outdoor unit.

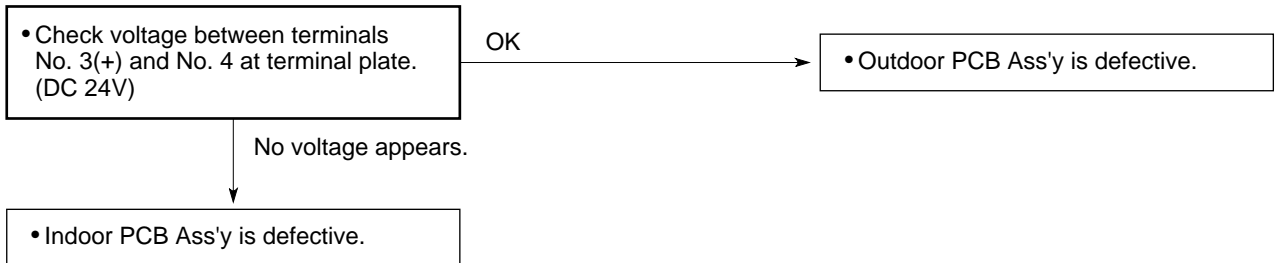

11-2-4. Only indoor unit does not run.

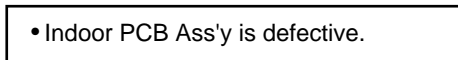

11-3. Some part of air conditioner does not operate.

11-3-1. Only indoor fan does not run.

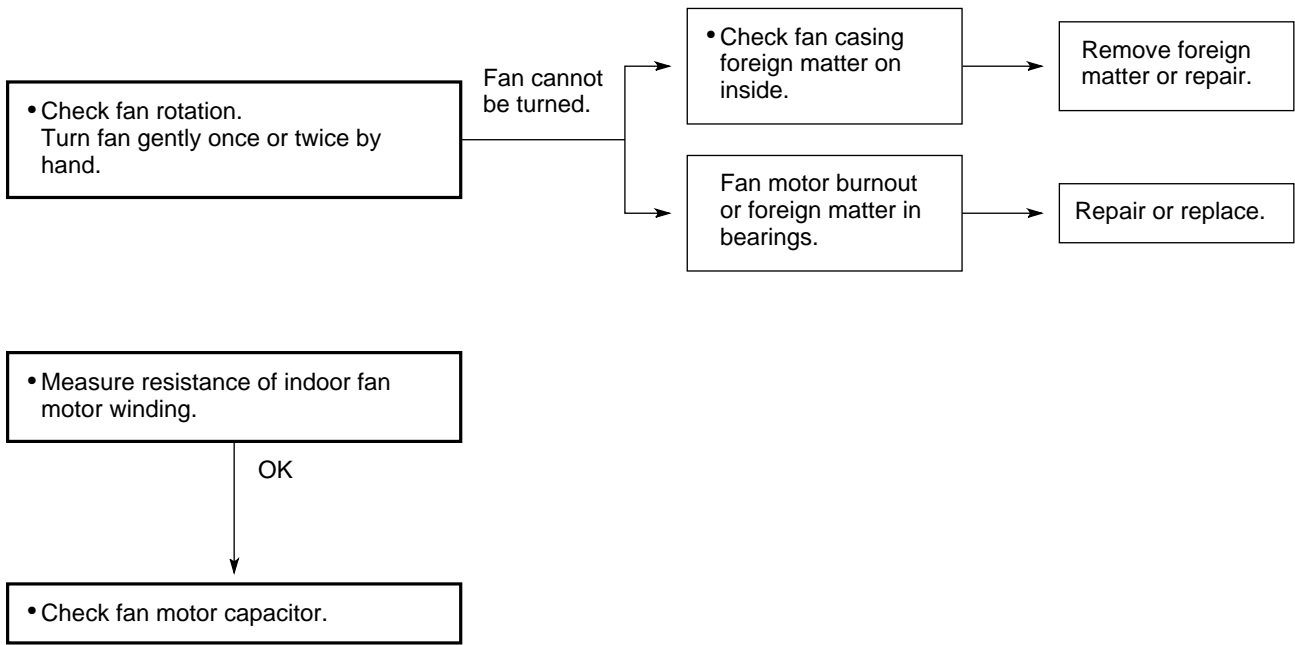

11-3-2. Only flap motor does not run.

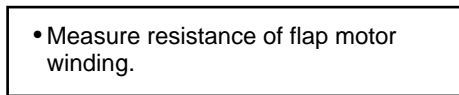

11-3-3. Only outdoor fan does not run.

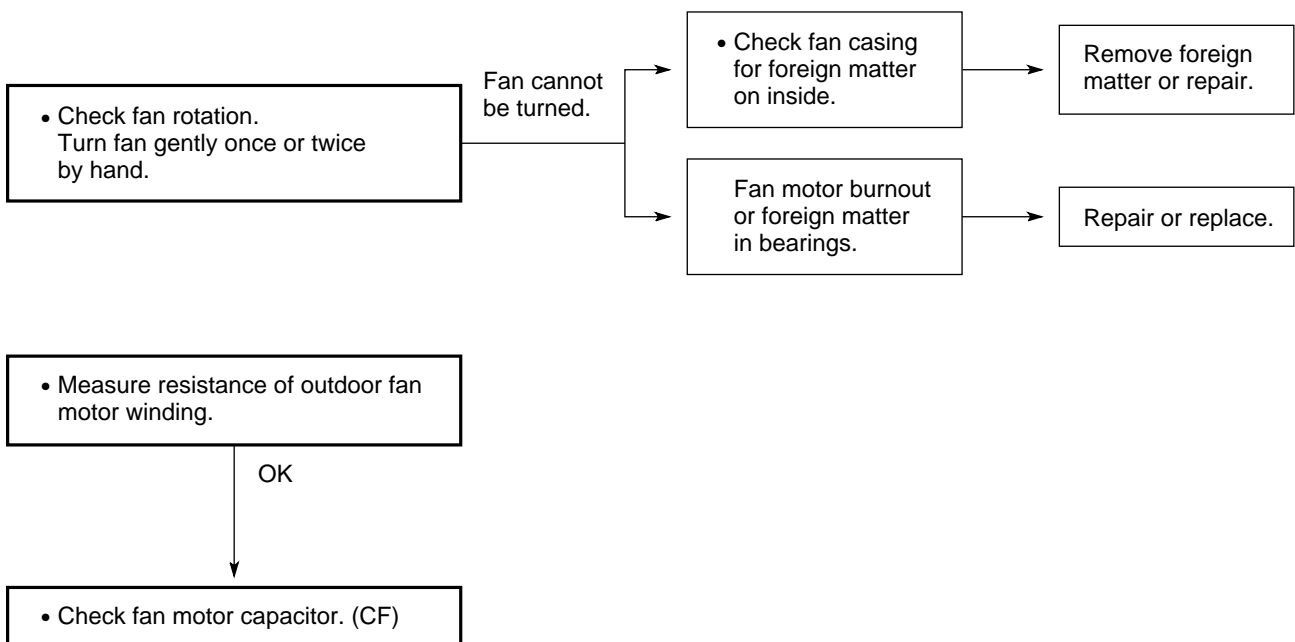

11-3-4. Only compressor does not run.

• Check compressor motor capacitor. (CA,CB)

• Measure resistance of compressor motor winding.

Overload relay is working. (OLR 1 to 4)

Measure coil resistance of power relay. (PRA,PRB)

YES

Temperature of compressor is abnormally high.

YES

Refrigerant gas shortage.

YES → Charge refrigerant gas (R22).

NO

Rotor may be locked up.

11-4-2. Poor cooling or heating.

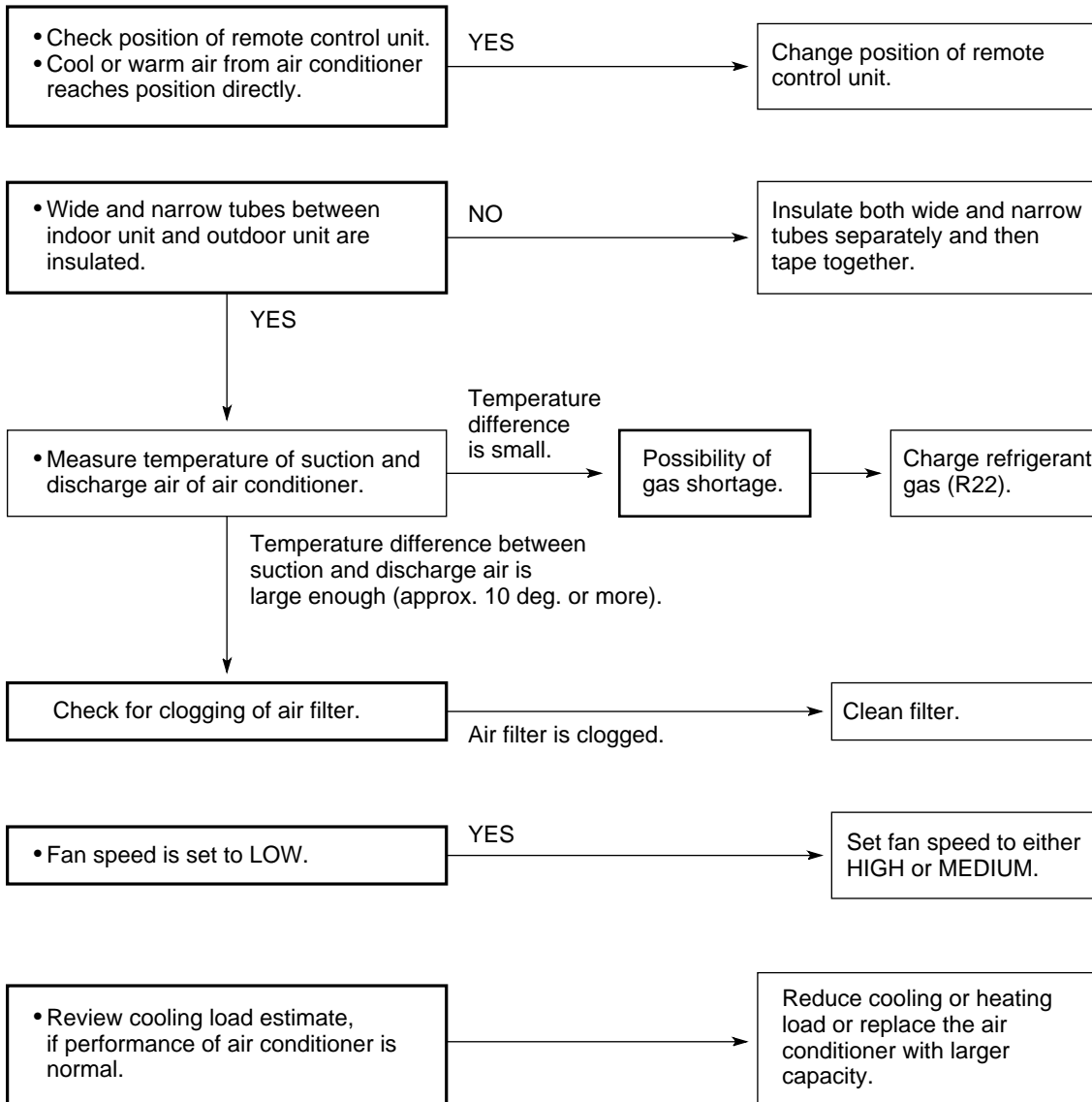

11-4-3. Excessive cooling or heating.

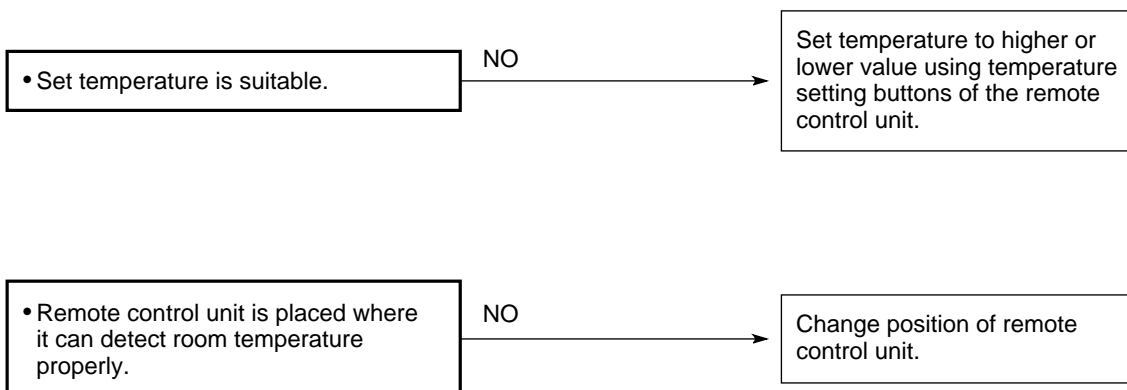

11-5. If a sensor is defective.

11-5-1. Indoor coil temp. thermistor (TH1) is defective.

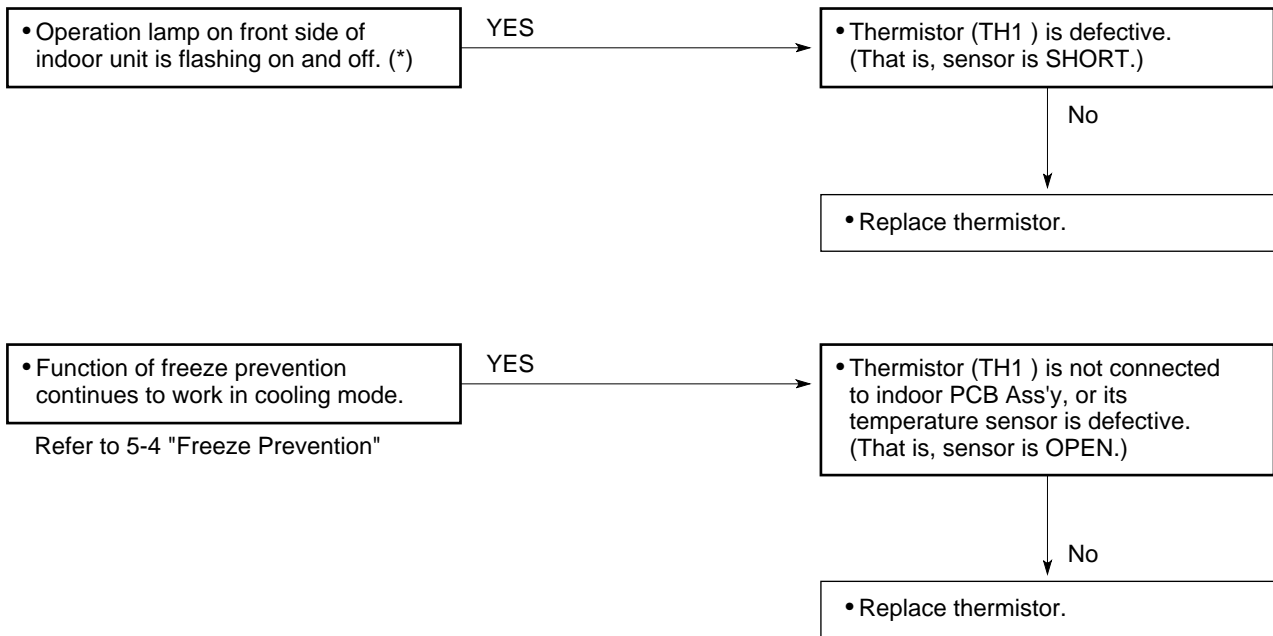

NOTE Alarm Signal (*)

Operation lamp on the front side of the indoor unit will flash on and off when the indoor coil thermistor is defective. (That is, sensor is SHORT). At the same time the outdoor unit will stop. Indoor unit will operate only for ventilation.

11-5-2. Room temp. thermistor (TH2) is defective.

A. Open

When thermistor opens, the air conditioner will be in the following conditions as the controller tries to detect extremely low room temperature.

- a) In Cooling mode: The air conditioner soon stops and will not start again. (Thermo.OFF)
Neither outdoor fan nor compressor runs.
- b) In Heating mode: The air conditioner continues to operate. (Thermo.ON)
Both the outdoor fan and compressor do not stop.
As a result, the room becomes too warm.

B. Short

When thermistor is short, the air conditioner will be in the following conditions as the controller tries to detect extremely high room temperature.

- a) In Cooling mode: The air conditioner continues to operate. (Thermo.ON)
Both the outdoor fan and compressor do not stop.
As a result, the room becomes too cold.
- b) In Heating mode: The air conditioner soon stops and will not start again. (Thermo.OFF)
Neither outdoor fan nor compressor runs.

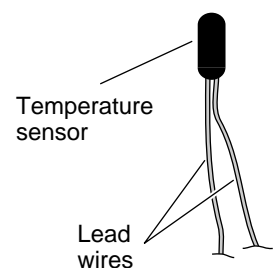

Thermistor Structure

NOTE Definition of Open or Short Circuit of Sensor (Thermistor)

Open... A lead wire is broken or disconnected or the circuit inside the temperature sensor is open .

Short... The protective cover of a lead wire has been damaged, and the exposed wire is touching another metal part, or both lead wires have become exposed and are touching each other. Alternatively, the circuit inside the temperature sensor is closed.

12. ARRANGEMENT OF ELECTRICAL COMPONENT

Indoor Unit **SAP-KM97GHS5A**
 SAP-KM97GHS5A/E

● Electric Parts

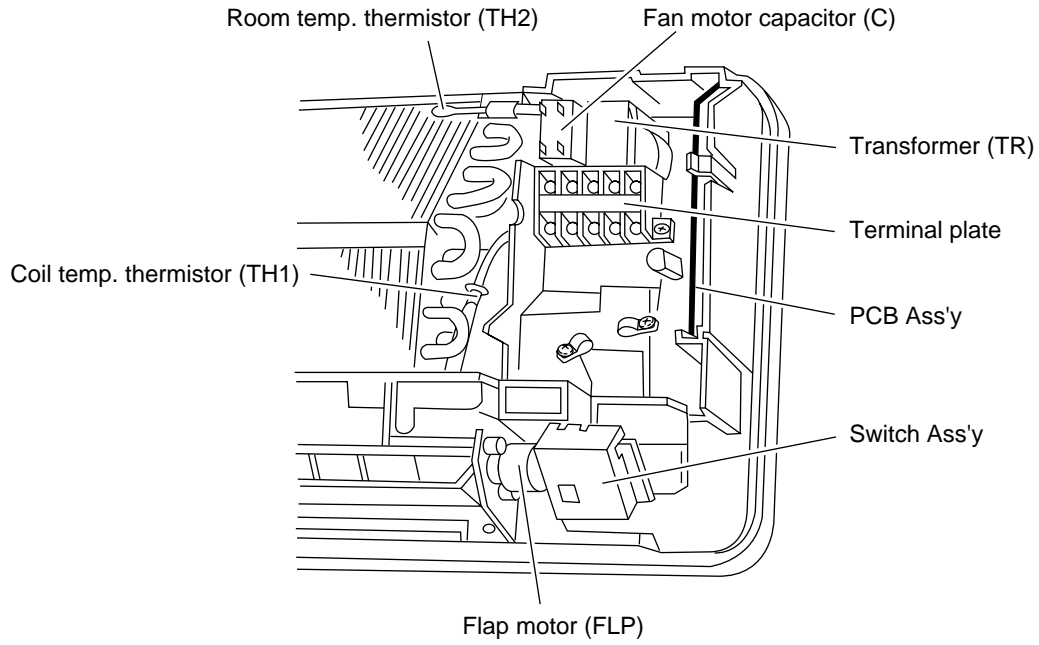

● **PCB Ass'y (Controller)**

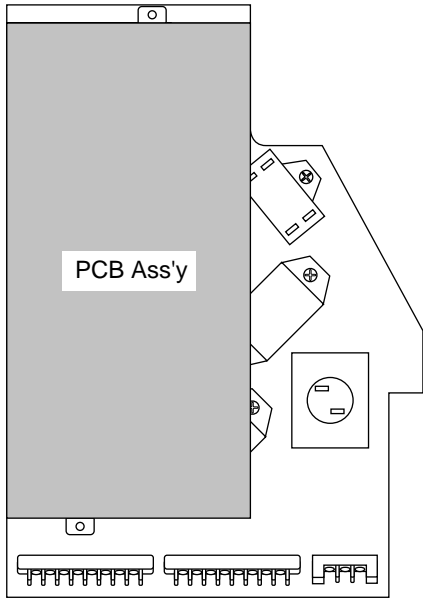

● **Parts Layout in Unit**

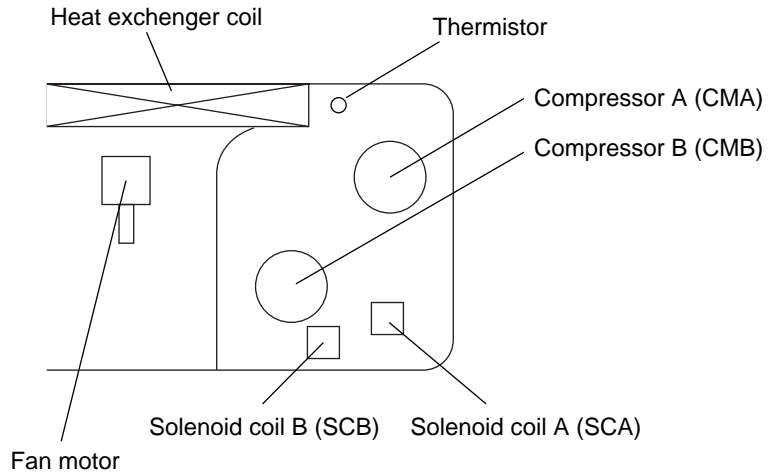

● **Electric Parts**

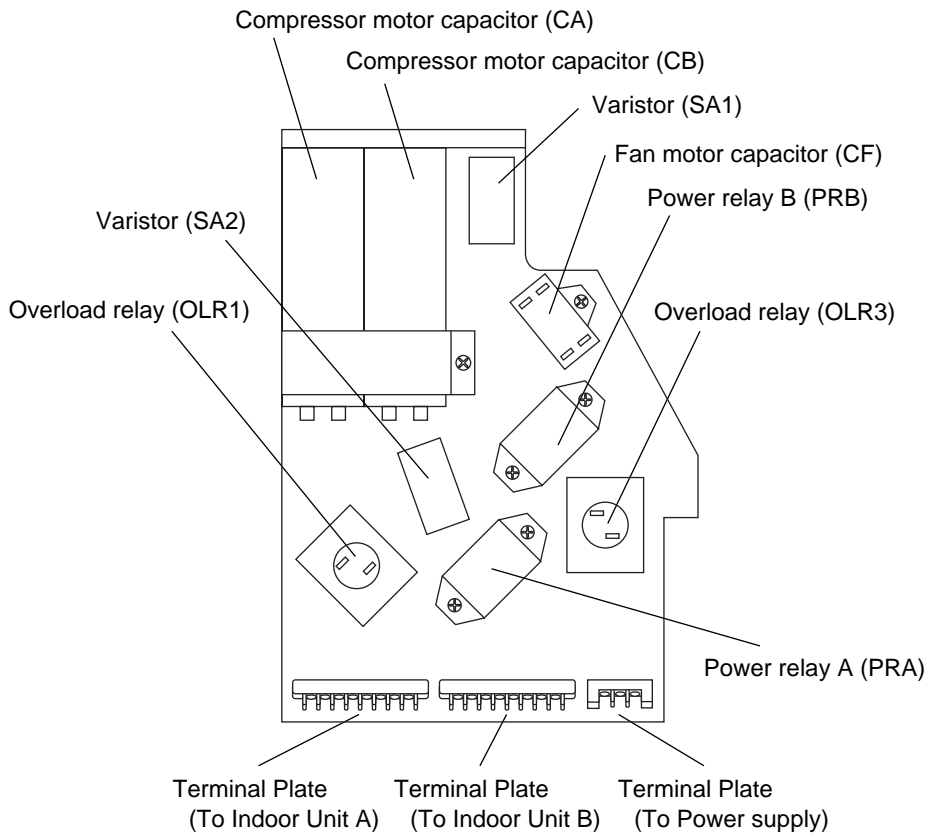

13. CHECKING ELECTRICAL COMPONENTS

13-1. Measurement of Insulation Resistance

- The insulation is in good condition if the resistance exceeds $2M\Omega$.

13-1-1. Power Supply Wires

Clamp the ground wire of the power supply wires with the lead clip of the insulation resistance tester and measure the resistance by placing a probe on either of the power wires. (Fig. 1)

Then measure the resistance between the ground wire and the other power wire. (Fig. 1)

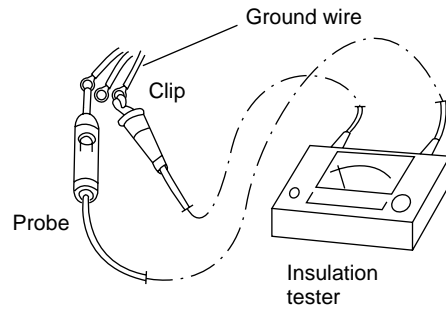

Fig. 1

13-1-2. Indoor Unit

Clamp an aluminum plate fin or copper tube with the lead clip of the insulation resistance tester and measure the resistance by placing a probe on each terminal screw except where the ground line is connected on the terminal plate. (Fig. 2)

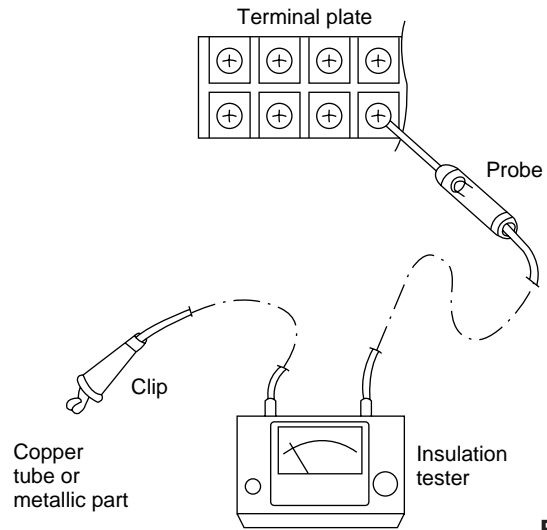

Fig. 2

13-1-3. Outdoor Unit

Clamp a metallic part of the unit with the lead clip of the insulation resistance tester and measure the resistance by placing a probe on each terminal screw where power supply lines are connected on the terminal plate. (Fig. 2)

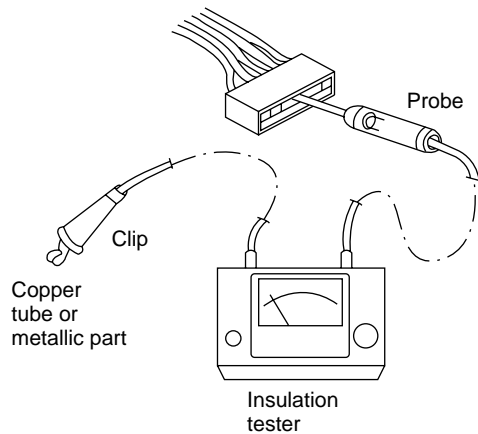

Fig. 3

13-1-4. Measurement of Insulation Resistance for Electrical Parts

Disconnect the lead wires of the desired electric part from terminal plate, capacitor, etc. Similarly disconnect the connector. Then measure the insulation resistance. (Figs. 1 to 4)

Refer to Electric Wiring Diagram.

NOTE

If the probe cannot enter the poles because the hole is too narrow then use a probe with a thinner pin.

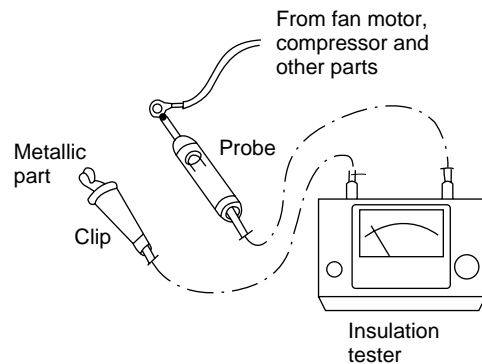

Fig. 4

13-2. Checking continuity of Fuse on PCB Ass'y

- Check for continuity using a multimeter as shown in Fig. 6.

NOTE

Method Used to Replace Fuse on PCB Ass'y

— Indoor PCB Ass'y —

1. Remove the PCB Ass'y from the electrical component box
2. Then pull out the fuse from the PCB Ass'y.(Fig.5a)

— Outdoor PCB Ass'y —

1. Remove the PCB Ass'y from the electrical component box.
2. Pull out the fuse at the metal clasp using pliers while heating the soldered leads on the back side of the PCB Ass'y with a soldering iron (30W or 60W).(Fig.5b)
3. Remove the fuse ends one by one. For replacement insert a fuse of the same rating and solder it. (Allow time to radiate heat during soldering so that the fuse does not melt.)

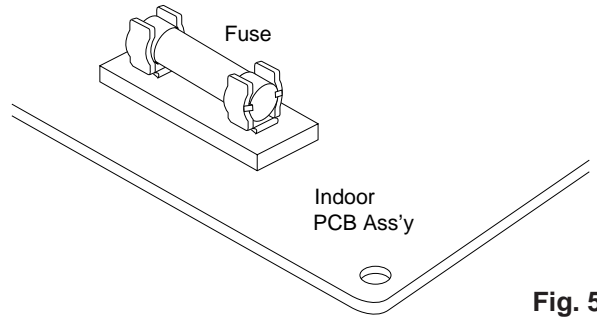

Fig. 5a

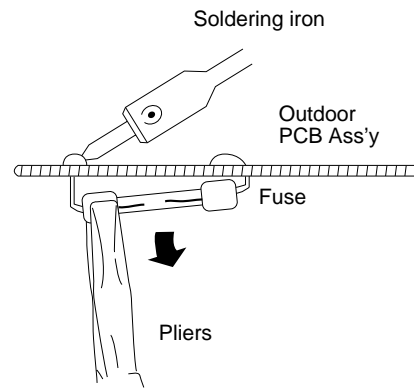

Fig. 5b

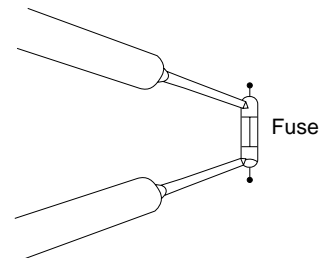

Fig. 6

13-3. Checking Motor Capacitor

Remove the lead wires from the capacitor terminals, and then place a probe on the capacitor terminals as shown in Fig. 7. Observe the deflection of the pointer, setting the resistance measuring range of the multimeter to the maximum value.

The capacitor is “good” if the pointer bounces to a great extent and then gradually returns to its original position.

The range of deflection and deflection time differ according to the capacity of the capacitor.

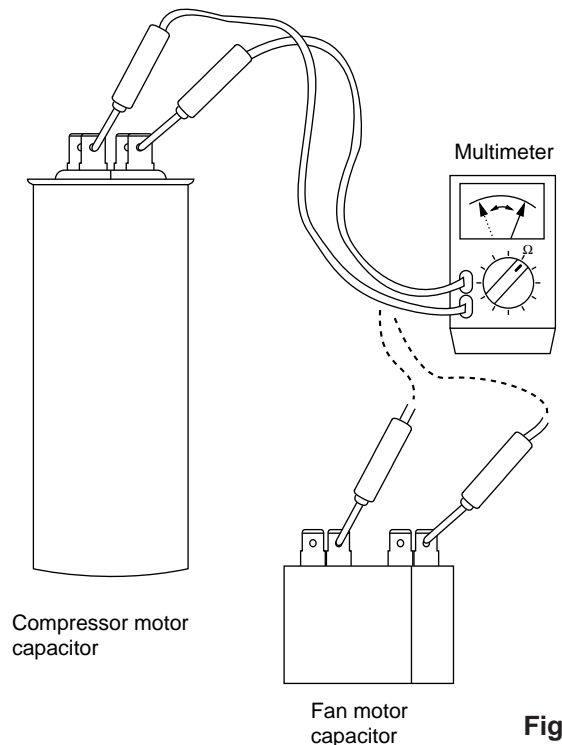

Fig. 7

Table of Contents

	Page
Installation Location	4
Electrical Requirements.....	4
Safety Instructions	4
Name of Parts	5
Using the Remote Control Unit.....	10
Operation with the Remot Control Unit.....	12
1. Operation	12
2. Adjusting the Fan Speed.....	13
3. Night Setback Mode	14
Special Remarks	16
Using the 12-Hour ON and OFF Timer.....	17
Using the 1-Hour OFF Timer	19
Adjusting the Airflow Direction.....	20
Operation without the Remote Control Unit.....	21
Care and Cleaning	21
Tips for Energy Saving	23
Troubleshooting	24
Special Multi System Operations.....	24

Ver. 1: KM97GHS5A-S + MC1827GH5-S
KM97GHS5A/E-S + MC1827GH5-E

SANYO

SANYO Electric Co.,Ltd
Osaka, Japan

SM700252 3/96/200

Printed in Japan