

Компания Полеель - официальный
дистрибьютор **SANYO**

www.poulel.ru
www.sanyo-airservice.ru

т. (495) 101-30-99

Кондиционеры
Сплит-системы
Полупромышленные кондиционеры
Мультizonальные **VRF** системы кондиционирования
Чиллеры

SERVICE MANUAL



FILE NO.

SPW-D253GH56 / SPW-C253GH5
SPW-D253GH56 / SPW-C253GH8
SPW-D363GH56 / SPW-C363GH8
SPW-D483GH56 / SPW-C483GH8

SPLIT SYSTEM AIR CONDITIONER

INDOOR MODEL No.	PRODUCT CODE No.	OUTDOOR MODEL No.	PRODUCT CODE No.
SPW-D253GH56	854 011 56	SPW-C253GH5	854 012 18
SPW-D253GH56	854 011 56	SPW-C253GH8	854 012 19
SPW-D363GH56	854 011 57	SPW-C363GH8	854 012 20
SPW-D483GH56	854 011 58	SPW-C483GH8	854 012 21

Indoor Unit

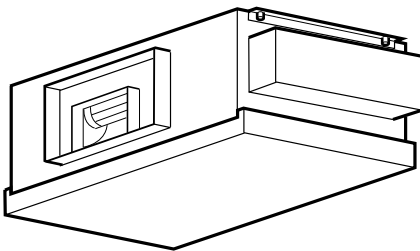

SPW-D253GH56
SPW-D363GH56
SPW-D483GH56

Outdoor Unit

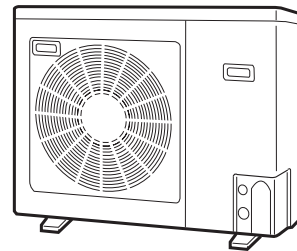

SPW-C253GH5
SPW-C253GH8

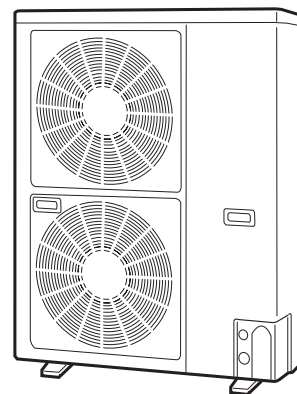

SPW-C363GH8
SPW-C483GH8

Section

1

2

3

4

5

Important

Please Read Before Starting

This air conditioning system meets strict safety and operating standards. As the installer or service person, it is an important part of your job to install or service the system so it operates safely and efficiently.

For safe installation and trouble-free operation, you must:

- Carefully read this instruction booklet before beginning.
- Follow each installation or repair step exactly as shown.
- Observe all local, state, and national electrical codes.
- Pay close attention to all warning and caution notices given in this manual.



WARNING

This symbol refers to a hazard or unsafe practice which can result in severe personal injury or death.



CAUTION

This symbol refers to a hazard or unsafe practice which can result in personal injury or product or property damage.

If Necessary, Get Help

These instructions are all you need for most installation sites and maintenance conditions. If you require help for a special problem, contact our sales/service outlet or your certified dealer for additional instructions.

In Case of Improper Installation

The manufacturer shall in no way be responsible for improper installation or maintenance service, including failure to follow the instructions in this document.

SPECIAL PRECAUTIONS

When Wiring



ELECTRICAL SHOCK CAN CAUSE SEVERE PERSONAL INJURY OR DEATH. ONLY A QUALIFIED, EXPERIENCED ELECTRICIAN SHOULD ATTEMPT TO WIRE THIS SYSTEM.

- Do not supply power to the unit until all wiring and tubing are completed or reconnected and checked.
- Highly dangerous electrical voltages are used in this system. Carefully refer to the wiring diagram and these instructions when wiring. Improper connections and inadequate grounding can cause **accidental injury or death**.
- **Ground the unit** following local electrical codes.
- Connect all wiring tightly. Loose wiring may cause overheating at connection points and a possible fire hazard.

When Transporting

Be careful when picking up and moving the indoor and outdoor units. Get a partner to help, and bend your knees when lifting to reduce strain on your back. Sharp edges or thin aluminum fins on the air conditioner can cut your fingers.

When Installing

...In a Room

Properly insulate any tubing run inside a room to prevent "sweating" that can cause dripping and water damage to walls and floors.

...In Moist or Uneven Locations

Use a raised concrete pad or concrete blocks to provide a solid, level foundation for the outdoor unit. This prevents water damage and abnormal vibration.

...In an area with High Winds

Securely anchor the outdoor unit down with bolts and a metal frame. Provide a suitable air baffle.

...In a Snowy Area (for Heat Pump-type Systems)

Install the outdoor unit on a raised platform that is higher than drifting snow. Provide snow vents.

When Connecting Refrigerant Tubing

- Execute enough ventilation in case refrigerant gas leaks during operations. Be careful not to contact the refrigerant gas with the flame. It will cause the generation of poisonous gas.
- Keep all tubing runs as short as possible.
- Use the flare method for connecting tubing.
- Apply refrigerant lubricant to the matching surfaces of the flare and union tubes before connecting them, then tighten the nut with a torque wrench for a leak-free connection.
- Check carefully for leaks before starting the test run.

NOTE

Depending on the system type, liquid and gas lines may be either narrow or wide. Therefore, to avoid confusion, the refrigerant tubing for your particular model is specified as either "narrow" or "wide" rather than as "liquid" or "gas".

When Servicing

- Turn the power OFF at the main power box before opening the unit to check or repair electrical parts and wiring.
- Keep your fingers and clothing away from any moving parts.
- Clean up the site when finished servicing. Don't forget to check that no metal scraps or bits of wiring have been left inside the unit.

WHO SHOULD USE THIS MANUAL

This service manual is made to assist the service technician apply his knowledge and training to this model air conditioner. This manual is written both for **experienced service persons** and **those who are new** to air conditioning service. To help those with less experience or who are new to this kind of unit we have included more explanations of basic procedures in simple language than is usual in some service manuals. The **experienced technician** will of course find he knows many of these things already and can go directly to the procedures and information he needs; the less experienced technician will better understand what to do even before he arrives on the job, and therefore be better able to work by himself as well as assist the more experienced technician.

TABLE OF CONTENTS

1. SPECIFICATIONS	7
1-1 Unit Specifications	8
1-2 Major Component Specifications	12
(A) Indoor Unit	12
(B) Outdoor Unit	15
1-3 Other Component Specifications	18
1-4 Dimensional Data	20
(A) Indoor Unit	20
(B) Outdoor Unit	21
1-5 Refrigerant Flow Diagram	23
1-6 Operating Range	24
2. PROCESSES AND FUNCTIONS	25
2-1 Room Temperature Control	26
(A) Cooling	26
(B) Heating	27
2-2 Cold Draft Prevention (Heating Cycle)	28
2-3 Automatic Fan Speed (Indoor Unit)	29
(A) Cooling	29
(B) Heating	29
2-4 Outdoor Fan Speed Control	30
(A) Cooling	30
(B) Heating	30
2-5 Freeze Prevention (Cooling)	31
2-6 Condensing Temperature Control (Cooling)	32
2-7 Overload Protection (Heating)	33
2-8 Discharge Temperature Control (Cooling and Heating)	34
2-9 Auto. Mode for Automatic Heating/Cooling Switching	34

2-10	Defrosting Control, Outdoor Heat Exchanger Coil (Heating).....	36
2-11	4-Way Valve, Solenoid Control	37
	(A) Normal Control Mode	37
	(B) AUTO Control Mode.....	38
2-12	Automatic Restart after Power Interruption	38
2-13	Electronic Refrigerant Control Valve	39
2-14	Compressor Discharge Gas Temperature	39
	(A) Cooling	39
	(B) Heating (Except During Defrosting).....	39
2-15	Compressor Current Detection Circuit	40
2-16	Dehumidifying Operation	41
2-17	Electronic Refrigerant Control Valve Control	42
2-18	Voltage Detection Control	43
3.	ELECTRICAL DATA	45
3-1	Indoor Unit (Electric Wiring Diagram, Schematic Diagram)	46
3-2	Outdoor Unit (Electric Wiring Diagram, Schematic Diagram).....	52
4.	SERVICE PROCEDURES	61
4-1	Troubleshooting	62
4-2	Checking the Electrical Components	95
5.	INSTRUCTION MANUAL	109

Introduction: *Read Me First!*

This manual will help you understand and service the air conditioner. To help you find the information you need, we have divided it into 5 main sections. Each section is divided into chapters with charts, tables and explanations to help you find and repair problems.

- ❑ **Section 1: Specifications**, tells you about the physical and electrical make up of the unit, as well as its heating and cooling capacities. Look in this section to find the correct values for components and functions.
- ❑ **Section 2: Processes and Functions**, explains each different part of the cooling and heating cycle, and how each control function reacts to changing conditions to keep the room at the set temperature range.
- ❑ **Section 3: Electrical Data**, which has fold-out schematic and wiring diagrams so you can find the parts you need to check when something is wrong, and see how they should be connected.
- ❑ **Section 4: Service Procedures**, has two main parts, a *diagnostic* chapter to help you find the specific component to replace or adjust, and a chapter with specific procedures and values to guide you in checking the electrical components in the unit.
- ❑ **Section 5: Instruction Manual**, is the same manual the user will have, and it contains general information about how to set and use the features of this particular air conditioner. Knowing this information will help you tell the owner how to use and care for this air conditioner, and also help you install and set the unit correctly.

HOW TO USE THIS MANUAL

You can use this manual both as a *reference* to find specific information about the capacity, functions and construction of this unit, and as a source of information to help you set up and maintain the unit.

When this unit is not working properly, and the cause is not known, you can use the procedures in **Section 3: Servicing Procedures** to find the problem, fix it, and restore the unit to its proper functioning.

This air conditioner has many helpful self diagnostic features to help you identify problem areas quickly.

So you will be ready when a problem happens, we suggest you look this manual over and become familiar with it by following these steps:

1. **Look at the TABLE OF CONTENTS** to get an idea of what is in this manual and where to find it.
2. **Look at the chapter about TROUBLE SHOOTING**, so you are familiar with the way the flow charts work. They are designed to guide you quickly through the possible causes for each kind of problem that is likely to happen to the Unit. Particularly read the introduction to this section, and the parts about the self-diagnosis and error codes which show on the display.
3. **Look at the chapter about CHECKING ELECTRICAL COMPONENTS**. You already know about most of these procedures. This chapter gives you the specific values and methods for these components. If you don't know some of these procedures, you can easily learn them here.
4. **Read the Instruction Manual!** The Instruction Manual is included here because it helps you help the user to set the temperature controls properly and know how to take care of any simple problems that may happen, as well as know when to call for service. The Instruction Manual also has illustrations, care, and installation information not found in the rest of the service manual. It is short, and if you read it carefully, you will be able to answer the customers questions easily, and also know the most efficient ways for setting times and temperatures.

Please use this manual to make your work easier, keep the air conditioner functioning well, and keep your customers satisfied.

1. SPECIFICATIONS

1-1	Unit Specifications	8
1-2	Major Component Specifications	12
	(A) Indoor Unit	12
	(B) Outdoor Unit	15
1-3	Other Component Specifications	18
1-4	Dimensional Data	20
	(A) Indoor Unit	20
	(B) Outdoor Unit	21
1-5	Refrigerant Flow Diagram	23
1-6	Operating Range	24

1-1 Unit Specifications

MODEL No.		Indoor Unit		SPW-D253GH56			
		Outdoor Unit		SPW-C253GH5			
POWER SOURCE		220 - 230 - 240 V / 1 Phase / 50 Hz					
PERFORMANCE				Cooling		Heating	
Capacity	kW			7.3		8	
	BTU / h			25,000		27,000	
Air circulation (Hi/Me/Lo)	m ³ / h			1,380/1,320/1,260			
Moisture removal (High)	Liters/h			3.1		-	
External static pressure(High)	mmAq(Pa)			19(186):at shipment			
ELECTRICAL RATINGS							
Voltage rating	V	220	230	240	220	230	240
Available voltage range	V	198 - 264			198 - 264		
Running amperes*	A	16.6	16.8	16.9	16.7	16.8	17
Max. running amperes**	A	18.7	18.7	18.7	18	17.9	17.8
Power input	kW	3.5	3.56	3.63	3.52	3.58	3.65
Power factor	%	95.8	92.1	89.5	95.8	92.7	89.5
C.O.P	W / W	2.09	2.05	2.01	2.27	2.23	2.19
Max. starting amperes	A	70	73	76	70	73	76
FEATURES							
Controls / Thermostat control				Microprocessor / I.C. thermostat			
Timer				ON/OFF 72-hours			
Fan speeds Indoor/Outdoor				3 and Automatic control/ 2 (Auto)			
Airflow direction (Indoor)				-			
Air filter				Field supply			
Remote controller				Option (Wired:RCS-SH80TG)			
Refrigerant control				Electronic Refrigerant Control Valve			
Drain pump (drain connection)				No (25A,OD32mm)			
Compressor				Rotary			
Operation sound	Indoor - Hi/Me/Lo	dB - A		44 / 43 / 42			
	Outdoor - Hi	dB - A		52			
REFRIGERANT TUBING							
Limit of tubing length		m (ft.)		50 (164)			
Limit of tubing length at shipment		m (ft.)		30 (98)			
Limit of elevation difference between the two units		m (ft.)		Outdoor unit is higher than indoor unit: 50 (164) Outdoor unit is lower than indoor unit: 30 (98)			
Refrigerant tube outer diameter	Narrow tube	mm (in)		6.35 (1 / 4)			
	Wide tube	mm (in)		15.88 (5 / 8)			
Refrigerant amount at shipment		kg		R22 - 3.0			
DIMENSIONS & WEIGHT				Indoor unit		Outdoor unit	
Unit dimensions	Height	mm (in)		420 (16-17/32)		735 (28-30/32)	
	Width	mm (in)		1,065 (41-30/32)		940 (37)	
	Depth	mm (in)		620 (24-13/32)		340 (13-12/32)	
Package dimensions	Height	mm (in)		513 (20-6/32)		826 (32-17/32)	
	Width	mm (in)		1,148 (45-6/32)		1,016 (40)	
	Depth	mm (in)		713 (28-2/32)		416 (16-12/32)	
Net weight	kg (lb)		47 (104)		71 (157)		
Shipping weight	kg (lb)		61 (134)		77 (170)		
Shipping volume	m ³ (Cu. ft.)		0.42 (14.8)		0.349 (12.3)		

DATA SUBJECT TO CHANGE WITHOUT NOTICE

Cooling :

Rating conditions(*) : Indoor air temperature 27 °C DB / 19 °C WB, Outdoor air temperature 35 °C DB

Full load conditions(**) Indoor air temperature 35 °C DB / 25 °C WB, Outdoor air temperature 45 °C DB

Heating :

Rating conditions(*) : Indoor air temperature 20 °C DB, Outdoor air temperature 7 °C DB / 6 °C DB

Full load conditions(**) Indoor air temperature 24 °C DB, Outdoor air temperature 24 °C DB / 15.5 °C WB

1-1 Unit Specifications

MODEL No.	Indoor Unit		SPW-D253GH56					
	Outdoor Unit		SPW-C253GH8					
POWER SOURCE	380 - 400 - 415 V / 3N / 50 Hz							
PERFORMANCE			Cooling			Heating		
Capacity	kW		7.3			8		
	BTU / h		25,000			27,000		
Air circulation (Hi/Me/Lo)	m ³ / h		1,380/1,320/1,260					
Moisture removal (High)	Liters/h		3.1			-		
External static pressure(High)	mmAq(Pa)		19(186):at shipment					
ELECTRICAL RATINGS								
Voltage rating	V		380	400	415	380	400	415
Available voltage range	V		342 - 456			342 - 456		
Running amperes*	A		5.4	5.2	5.1	5.6	5.4	5.4
Max. running amperes**	A		5.9	5.7	5.6	6.4	6.1	5.9
Power input	kW		3.11	3.15	3.2	3.22	3.25	3.3
Power factor	%		87.5	87.4	87.3	87.4	86.9	85
C.O.P	W / W		2.35	2.32	2.28	2.48	2.46	2.42
Max. starting amperes	A		28	30	31	28	30	31
FEATURES								
Controls / Thermostat control	Microprocessor / I.C. thermostat							
Timer	ON/OFF 72-hours							
Fan speeds Indoor/Outdoor	3 and Automatic control/ 2 (Auto)							
Airflow direction (Indoor)	-							
Air filter	Field supply							
Remote controller	Option (Wired:RCS-SH80TG)							
Refrigerant control	Electronic Refrigerant Control Valve							
Drain pump (drain connection)	No (25A,OD32mm)							
Compressor	Rotary							
Operation sound	Indoor - Hi/Me/Lo	dB - A	44 / 43 / 42					
	Outdoor - Hi	dB - A	52					
REFRIGERANT TUBING								
Limit of tubing length	m (ft.)		50 (164)					
Limit of tubing length at shipment	m (ft.)		30 (98)					
Limit of elevation difference between the two units	m (ft.)		Outdoor unit is higher than indoor unit: 50 (164) Outdoor unit is lower than indoor unit: 30 (98)					
Refrigerant tube outer diameter	Narrow tube	mm (in)	6.35 (1 / 4)					
	Wide tube	mm (in)	15.88 (5 / 8)					
Refrigerant amount at shipment	kg		R22 - 3.0					
DIMENSIONS & WEIGHT								
Unit dimensions	Height	mm (in)	420 (16-17/32)			735 (28-30/32)		
	Width	mm (in)	1,065 (41-30/32)			940 (37)		
	Depth	mm (in)	620 (24-13/32)			340 (13-12/32)		
Package dimensions	Height	mm (in)	513 (20-6/32)			826 (32-17/32)		
	Width	mm (in)	1,148 (45-6/32)			1,016 (40)		
	Depth	mm (in)	713 (28-2/32)			416 (16-12/32)		
Net weight	kg (lb)	47 (104)			71 (157)			
Shipping weight	kg (lb)	61 (134)			77 (170)			
Shipping volume	m ³ (Cu. ft.)	0.42 (14.8)			0.349 (12.3)			

DATA SUBJECT TO CHANGE WITHOUT NOTICE

Cooling :

Rating conditions(*) : Indoor air temperature 27 °C DB / 19 °C WB, Outdoor air temperature 35 °C DB
 Full load conditions(**) Indoor air temperature 35 °C DB / 25 °C WB, Outdoor air temperature 45 °C DB

Heating :

Rating conditions(*) : Indoor air temperature 20 °C DB, Outdoor air temperature 7 °C DB / 6 °C DB
 Full load conditions(**) Indoor air temperature 24 °C DB, Outdoor air temperature 24 °C DB / 15.5 °C WB



1-1 Unit Specifications

MODEL No.	Indoor Unit		SPW-D363GH56					
	Outdoor Unit		SPW-C363GH8					
POWER SOURCE	380 - 400 - 415 V / 3N / 50 Hz							
PERFORMANCE				Cooling		Heating		
Capacity	kW		10.6		11.4			
	BTU / h		36,000		39,000			
Air circulation (Hi/Me/Lo)	m ³ / h		1,800/1,680/1,500					
Moisture removal (High)	Liters/h		4.5		-			
External static pressure(High)	mmAq(Pa)		18(176):at shipment					
ELECTRICAL RATINGS								
Voltage rating	V		380	400	415	380	400	415
Available voltage range	V		342 - 456			342 - 456		
Running amperes*	A		5.8	5.7	5.6	5.9	5.7	5.6
Max. running amperes**	A		6.8	6.7	6.5	6.6	6.5	6.5
Power input	kW		3.4	3.44	3.47	3.5	3.55	3.6
Power factor	%		89.1	87.1	86.2	90.1	89.9	89.4
C.O.P	W / W		3.12	3.08	3.05	3.26	3.21	3.17
Max. starting amperes	A		32	34	35	32	34	35
FEATURES								
Controls / Thermostat control	Microprocessor / I.C. thermostat							
Timer	ON/OFF 72-hours							
Fan speeds Indoor/Outdoor	3 and Automatic control/ 2 (Auto)							
Airflow direction (Indoor)	-							
Air filter	Field supply							
Remote controller	Option (Wired:RCS-SH80TG)							
Refrigerant control	Electronic Refrigerant Control Valve							
Drain pump (drain connection)	No (25A,OD32mm)							
Compressor	Rotary							
Operation sound	Indoor - Hi/Me/Lo	dB - A	45 / 44 / 42					
	Outdoor - Hi	dB - A	53					
REFRIGERANT TUBING								
Limit of tubing length	m (ft.)		50 (164)					
Limit of tubing length at shipment	m (ft.)		30 (98)					
Limit of elevation difference between the two units	m (ft.)		Outdoor unit is higher than indoor unit: 50 (164) Outdoor unit is lower than indoor unit: 30 (98)					
Refrigerant tube outer diameter	Narrow tube	mm (in)	9.52 (3 / 8)					
	Wide tube	mm (in)	19.05 (3 / 4)					
Refrigerant amount at shipment	kg		R22 - 3.5					
DIMENSIONS & WEIGHT								
Unit dimensions	Height	mm (in)	420 (16-17/32)			1,235 (48-20/32)		
	Width	mm (in)	1,065 (41-30/32)			940 (37)		
	Depth	mm (in)	620 (24-13/32)			340 (13-12/32)		
Package dimensions	Height	mm (in)	513 (20-6/32)			1,326 (52-7/32)		
	Width	mm (in)	1,148 (45-6/32)			1,016 (40)		
	Depth	mm (in)	713 (28-2/32)			416 (16-12/32)		
Net weight	kg (lb)	50 (110)			94 (207)			
Shipping weight	kg (lb)	64 (141)			101 (223)			
Shipping volume	m ³ (Cu. ft.)	0.42 (14.8)			0.56 (19.8)			

DATA SUBJECT TO CHANGE WITHOUT NOTICE

Cooling :

Rating conditions(*) : Indoor air temperature 27 °C DB / 19 °C WB, Outdoor air temperature 35 °C DB
 Full load conditions(**) Indoor air temperature 35 °C DB / 25 °C WB, Outdoor air temperature 45 °C DB

Heating :

Rating conditions(*) : Indoor air temperature 20 °C DB, Outdoor air temperature 7 °C DB / 6 °C DB
 Full load conditions(**) Indoor air temperature 24 °C DB, Outdoor air temperature 24 °C DB / 15.5 °C WB

1-1 Unit Specifications

MODEL No.		Indoor Unit		SPW-D483GH56			
		Outdoor Unit		SPW-C483GH8			
POWER SOURCE		380 - 400 - 415 V / 3N / 50 Hz					
PERFORMANCE		Cooling			Heating		
Capacity	kW	14			16		
	BTU / h	47,800			54,600		
Air circulation (Hi/Me/Lo)	m ³ / h	2,160/2,100/1,980					
Moisture removal (High)	Liters/h	6.6			-		
External static pressure(High)	mmAq(Pa)	17(167):at shipment					
ELECTRICAL RATINGS							
Voltage rating	V	380	400	415	380	400	415
Available voltage range	V	342 - 456			342 - 456		
Running amperes*	A	9.1	9.2	9.4	9.6	9.6	9.9
Max. running amperes**	A	9.7	9.7	9.9	10.4	10.1	9.8
Power input	kW	5.25	5.5	5.63	5.62	5.81	5.93
Power factor	%	87.7	86.3	83.3	88.9	87.4	83.3
C.O.P	W / W	2.67	2.55	2.49	2.85	2.75	2.7
Max. starting amperes	A	73	75	77	73	75	77
FEATURES							
Controls / Thermostat control		Microprocessor / I.C. thermostat					
Timer		ON/OFF 72-hours					
Fan speeds Indoor/Outdoor		3 and Automatic control/ 2 (Auto)					
Airflow direction (Indoor)		-					
Air filter		Field supply					
Remote controller		Option (Wired:RCS-SH80TG)					
Refrigerant control		Electronic Refrigerant Control Valve					
Drain pump (drain connection)		No (25A,OD32mm)					
Compressor		Scroll					
Operation sound	Indoor - Hi/Me/Lo	dB - A			47 / 46 / 44		
	Outdoor - Hi	dB - A			55		
REFRIGERANT TUBING							
Limit of tubing length	m (ft.)	50 (164)					
Limit of tubing length at shipment	m (ft.)	30 (98)					
Limit of elevation difference between the two units	m (ft.)	Outdoor unit is higher than indoor unit: 50 (164) Outdoor unit is lower than indoor unit: 30 (98)					
Refrigerant tube outer diameter	Narrow tube	mm (in)			9.52 (3 / 8)		
	Wide tube	mm (in)			19.05 (3 / 4)		
Refrigerant amount at shipment	kg	R22 - 4.5					
DIMENSIONS & WEIGHT		Indoor unit			Outdoor unit		
Unit dimensions	Height	mm (in)			450 (17-23/32)		
	Width	mm (in)			1,235 (48-20/32)		
	Depth	mm (in)			940 (37)		
Package dimensions	Height	mm (in)			620 (24-13/32)		
	Width	mm (in)			340 (13-12/32)		
	Depth	mm (in)			513 (20-6/32)		
Net weight	kg (lb)			1,326 (52-7/32)			
Shipping weight	kg (lb)			1,016 (40)			
Shipping volume	m ³ (Cu. ft.)			416 (16-12/32)			
		54 (119)			108 (238)		
		69 (152)			115 (254)		
		0.42 (14.8)			0.56 (19.8)		

DATA SUBJECT TO CHANGE WITHOUT NOTICE

Cooling :

Rating conditions(*) : Indoor air temperature 27 °C DB / 19 °C WB, Outdoor air temperature 35 °C DB

Full load conditions(**) Indoor air temperature 35 °C DB / 25 °C WB, Outdoor air temperature 45 °C DB

Heating :

Rating conditions(*) : Indoor air temperature 20 °C DB, Outdoor air temperature 7 °C DB / 6 °C DB

Full load conditions(**) Indoor air temperature 24 °C DB, Outdoor air temperature 24 °C DB / 15.5 °C WB



1-2 Major Component Specifications

(A) Indoor Unit

MODEL No.		SPW-D253GH56	
Source		220 - 230 - 240 V / 1 phase / 50 Hz	
Remote controller (Option)		RCS - SH80TG (Microprocessor)	
Controller P.C.B. Ass'y		CR - X253GH (Microprocessor)	
Fan (Number...diameter)	mm	Centrifugal (2 ... ø 220)	
Fan Motor			
Model...Nominal output	W	KFC4X - 201B5P ... 200 W	
Source		220 - 230 - 240 V / 1 phase / 50 Hz	
No. of pole...r.p.m. (230 V, High)	rpm.	4 ... 1,004	
Coil resistance (Ambient temperature 20 °C)	Ω	BRN - WHT : 13.75 , ORG - YEL : 2.21 WHT - VLT : 4.47 , YEL - BLK : 10.33 VLT - ORG : 1.20 , BLK - PNK : 12.90	
Safety device			
Operating temperature	Open °C	130 ± 8 °C	
	Close °C	79 ± 15 °C	
Run capacitor	VAC, μF	440 V, 5.0 μF	
Electronic refrigerant control valve			
Solenoid control model		DKV - MOZS550E0	
Coil resistance (at 20 °C)	Ω	ORG - GRY : 46 , YEL - GRY : 46 RED - GRY : 46 , BLK - GRY : 46	
Solenoid control valve model		IKV - 24D12	
Heat exchanger			
Coil		Aluminum plate fin / Copper tube	
Rows...fin pitch	mm	3 ... 2.0	
Face area	m ²	0.233	

1

1-2 Major Component Specifications

(A) Indoor Unit

MODEL No.		SPW-D363GH56	
Source		220 - 230 - 240 V / 1 phase / 50 Hz	
Remote controller (Option)		RCS - SH80TG (Microprocessor)	
Controller P.C.B. Ass'y		CR - X253GH (Microprocessor)	
Fan (Number...diameter)	mm	Centrifugal (1 ... ø 220)	
Fan Motor			
Model...Nominal output	W	KFC4X - 201B5P ... 200 W	
Source		220 - 230 - 240 V / 1 phase / 50 Hz	
No. of pole...r.p.m. (230 V, High)	rpm.	4 ... 1,134	
Coil resistance (Ambient temperature 20 °C)	Ω	BRN - WHT : 13.75 , ORG - YEL : 2.21 WHT - VLT : 4.47 , YEL - BLK : 10.33 VLT - ORG : 1.20 , BLK - PNK : 12.90	
Safety device			
Operating temperature	Open °C	130 ± 8 °C	
	Close °C	79 ± 15 °C	
Run capacitor	VAC, μF	440 V, 7.0 μF	
Electronic refrigerant control valve			
Solenoid control model		EKV-MOZS559E0	
Coil resistance (at 20 °C)	Ω	ORG - GRY : 46 , YEL - GRY : 46 RED - GRY : 46 , BLK - GRY : 46	
Solenoid control valve model		HKV - 30D16	
Heat exchanger			
Coil		Aluminum plate fin / Copper tube	
Rows...fin pitch	mm	4 ... 2.0	
Face area	m ²	0.273	



1-2 Major Component Specifications

(A) Indoor Unit

MODEL No.		SPW-D483GH56	
Source		220 - 230 - 240 V / 1 phase / 50 Hz	
Remote controller (Option)		RCS - SH80TG (Microprocessor)	
Controller P.C.B. Ass'y		CR - X253GH (Microprocessor)	
Fan (Number...diameter)	mm	Centrifugal (1 ... ø 250)	
Fan Motor			
Model...Nominal output	W	KFC4Q - 401A5P ... 400 W	
Source		220 - 230 - 240 V / 1 phase / 50 Hz	
No. of pole...r.p.m. (230 V, High)	rpm.	4 ... 1,077	
Coil resistance (Ambient temperature 20 °C)	Ω	BRN - WHT : 11.05 , ORG - YEL : 4.57 WHT - VLT : 1.80 , YEL - PNK : 7.70 VLT - ORG : 1.00	
Safety device			
Operating temperature	Open °C	130 ± 8 °C	
	Close °C	79 ± 15 °C	
Run capacitor	VAC, μF	440 V, 7 μF × 2	
Electronic refrigerant control valve			
Solenoid control model		EKV - MOZS559E0	
Coil resistance (at 20 °C)	Ω	ORG - GRY : 46 , YEL - GRY : 46 RED - GRY : 46 , BLK - GRY : 46	
Solenoid control valve model		HKV - 30D16	
Heat exchanger			
Coil		Aluminum plate fin / Copper tube	
Rows...fin pitch	mm	4...2.0	
Face area	m ²	0.273	

1

1-2 Major Component Specifications (B) Outdoor Unit

MODEL No.		SPW-C253GH5	
Source		220 - 230 - 240 V / 1 phase / 50 Hz	
Controller P.C.B. Ass'y		CR - C253GH5 (Microprocessor)	
Control circuit fuse		250 V, 3.15 A	
Compressor		Rotary (Hermetic)	
Model number		C - R221H5W	
Source		220 - 240 V / 1 phase / 50 Hz	
Nominal output	W	2200	
Compressor oil	cc	1500	
Coil resistance (Ambient temperature 25 °C)	Ω	C - R : 0.76 , R - S : 3.52 C - S : 2.76	
Safety devices			
Overload relay models		Internal type	
Operating temperature	Open °C	160 ± 5	
	Close °C	87 ± 11	
Crank case heater		240V, 25 W	
Refrigerant amount at shipment		kg	
		R22 - 3.0	
High pressure switch		ACB - 1TB07	
Set pressure	OFF kg/cm ²	30 ^{+2.0} _{+0.5}	
	ON kg/cm ²	24 ± 2.0	
Fan		Propeller	
Number...diameter	mm	1 ø460	
Fan speeds		2 (AUTO)	
Fan motor			
Model		KFC6T - 91C5P	
Source		220 - 230 - 240 V / 1 phase / 50 Hz	
No. of pole rpm (230V, High / Med.)		6...772 / 376	
Nominal output	W	70	
Coil resistance (Ambient temperature 20°C)	Ω	WHT - BRN : 127.3 , VLT - YEL : 15.0 WHT - VLT : 56.7 , YEL - PNK : 7.2	
Safety device		Internal type	
Operating temperature	Open °C	130 ± 8	
	Close °C	79 ± 15	
Run capacitor	VAC, μF	440 V, 6 μF	
Heat exchange			
Coil		Aluminium plate fin / Copper tube	
Rows fin pitch	mm	2 2.0	
Face area	m ²	0.616	

1-2 Major Component Specifications

(B) Outdoor Unit

MODEL No.		SPW-C253GH8	
Source		380 - 400 - 415 V / 3 phase / 50 Hz	
Controller P.C.B. Ass'y		CR - C253GH (Microprocessor)	
Control circuit fuse		250 V, 3.15 A	
Compressor		Rotary (Hermetic)	
Model number		C - R224H8U	
Source		380 - 400 - 415 V / 3 phase / 50 Hz	
Nominal output	W	2400	
Compressor oil	cc	1350	
Coil resistance (Ambient temperature 25 °C)	Ω	T - R : 5.54 , R - S : 5.54 S - T : 5.54	
Safety devices			
Overload relay models		Internal type	
Operating temperature	Open °C	120 ± 5	
	Close °C	98 ± 11	
Crank case heater		240V, 25 W	
Refrigerant amount at shipment		kg	R22 - 3.0
High pressure switch		ACB - 1TB07	
Set pressure	OFF kg/cm ²	30 ^{+2.0} / _{+0.5}	
	ON kg/cm ²	24 ± 2.0	
Fan		Propeller	
Number...diameter	mm	1 ø460	
Fan speeds		2 (AUTO)	
Fan motor			
Model		KFC6T - 91C5P	
Source		220 - 230 - 240 V / 1 phase / 50 Hz	
No. of pole rpm (230 V, High / Med.)		6...772 / 376	
Nominal output	W	70	
Coil resistance (Ambient temperature 20°C)	Ω	WHT - BRN : 127.3 , VLT - YEL : 15.0 WHT - VLT : 56.7 , YEL - PNK : 7.2	
Safety device		Internal type	
Operating temperature	Open °C	130 ± 8	
	Close °C	79 ± 15	
Run capacitor	VAC, μF	440 V, 6 μF	
Heat exchange			
Coil		Aluminium plate fin / Copper tube	
Rows fin pitch	mm	2 2.0	
Face area	m ²	0.616	

1

1-2 Major Component Specifications

(B) Outdoor Unit

MODEL No.		SPW-C363GH8	SPW-C483GH8
Source		380 - 400 - 415 V / 3 phase / 50 Hz	
Controller P.C.B. Ass'y		CR - C253GH (Microprocessor)	
Control circuit fuse		250 V, 3.15 A	
Compressor		Rotary (Hermetic)	Scroll (Hermetic)
Model number		C - R243H8V	ZR61KC - TFD - 522
Source		380 - 400 - 415 V / 3 phase / 50 Hz	
Nominal output	W	2,400	3,700
Compressor oil	cc	1,350	2,130
Coil resistance (Ambient temperature 25 °C)	Ω	T - R : 5.54 , R - S : 5.54 S - T : 5.54	T 1 - T2 : 2.72 , T2 - T3 : 2.72 T 3 - T1 : 2.72
Crank case heater		240 V, 25 W	240 V, 36 W
Safety devices		Internal type	
Overload relay models		Internal type	
Operating temperature	Open °C	120 ± 5	130
	Close °C	98 ± 11	61
Refrigerant amount at shipment		kg	R22 - 3.5 R22 - 4.5
High pressure switch		ACB - 1TB07	
Set pressure	OFF kg/cm ²	30 ^{+2.0} _{+0.5}	
	ON kg/cm ²	24 ± 2.0	
Fan		Propeller	
Number...diameter	mm	2 ø460	
Fan speeds		2 (AUTO)	
Fan motor		KFC6T - 91C5P × 2	
Model		KFC6T - 91C5P × 2	
Source		220 - 230 - 240 V / 1 phase / 50 Hz	
No. of pole rpm (230V, High / Med.)		6...772 / 376	
Nominal output	W	70 W × 2	
Coil resistance (Ambient temperature 20°C)	Ω	BRN - WHT : 127.3 , VLT - YEL : 15.0 WHT - VLT : 56.7 , YEL - PNK : 7.2	
Safety device		Internal type	
Operating temperature	Open °C	130 ± 8	
	Close °C	79 ± 15	
Run capacitor	VAC, μF	440 V, 6 μF × 2	
Heat exchange		Aluminium plate fin / Copper tube	
Coil		Aluminium plate fin / Copper tube	
Rows fin pitch	mm	2 2.0	
Face area	m ²	1.08	

1-3 Other Component Specifications

MODEL No.		Indoor Unit	Outdoor Unit
		SPW-D253GH56	SPW-C253GH5, SPW-C253GH8
Power Transformer		ATR - II215TB	ATR - I65B
Rated			
Primary	V. Hz	AC 230 V, 50 Hz	AC 230 V, 50 Hz
Secondary		10.2V, 1.4 A	14 V, 0.4 A
		14 V, 0.5 A	—
Coil resistance	Ω	WHT – WHT : 110 , BRN – BRN : 0.5 RED – RED : 2.3	WHT – WHT : 300 , BRN – BRN : 2.2
Thermal cut off temperature	°C	145	145
Thermistor (Coil sensor)		PBC - 41E - S36, PBC - 41E - S25, PBC - 41E - S4	
Coil resistance	kΩ	-10 °C : 23.7 , - 5 °C : 18.8 , 0 °C : 15.0 , 5 °C : 12.1 ,	10 °C : 9.7 20 °C : 6.5 30 °C : 4.4 40 °C : 3.1 45 °C : 2.6
Thermistor (Room or coil sensor)		KTEC - 35 - S2	PTC - 51H - S1
Coil resistance	kΩ	0 °C : 16.5 , 40 °C : 2.7 5 °C : 12.8 , 45 °C : 2.2 10 °C : 10.0 , 50 °C : 1.8 20 °C : 6.3 , 55 °C : 1.5 30 °C : 4.0 ,	60 °C : 13.8 , 90 °C : 5.1 70 °C : 9.7 , 100 °C : 3.8 75 °C : 8.2 , 110 °C : 2.8 80 °C : 7.0 , 120 °C : 2.2 85 °C : 5.9 , 130 °C : 1.7
Relay		—	FMCA - 1SZ607
Coil rated	V	—	AC 220 - 240 V
Contact rating	V.A	—	AC 440 V, 13 A
Coil resistance (at 25 °C)	Ω	—	—
Solenoid control valve or coil			
Solenoid control valve		IKV - 24D12	CHV - 0201
Solenoid coil		DKV - MOZS550E0	CHV - 01AJ504D1
Float switch		FS - 3502 - 204	—
Rated (Contact rated)		AC 230 V, 50 W	—

1

1-3 Other Component Specifications

MODEL No.	Indoor Unit		Outdoor Unit	
	SPW-D363GH56	SPW-D483GH56	SPW-C363GH8	SPW-C483GH8
Power Transformer	ATR - II215TB		ATR - I65B	
Rated				
Primary	V. Hz	AC 230 V, 50 Hz	AC 230 V, 50 Hz	
Secondary		10.2V, 1.4 A	14 V, 0.4 A	
		14 V, 0.5 A	—	
Coil resistance	Ω	WHT – WHT : 110 , BRN – BRN : 0.5 RED – RED : 2.3	WHT – WHT : 300 , BRN – BRN : 2.2	
Thermal cut off temperature	°C	145	145	
Thermistor (Coil sensor)	PBC - 41E - S36, PBC - 41E - S25, PBC - 41E - S4			
Coil resistance	kΩ	-10 °C : 23.7 , -5 °C : 18.8 , 0 °C : 15.0 , 5 °C : 12.1 ,	10 °C : 9.7 20 °C : 6.5 30 °C : 4.4 40 °C : 3.1 45 °C : 2.6	
Thermistor (Room or coil sensor)	KTEC - 35 - S2		PTC - 51H - S1	
Coil resistance	kΩ	0 °C : 16.5 , 40 °C : 2.7 5 °C : 12.8 , 45 °C : 2.2 10 °C : 10.0 , 50 °C : 1.8 20 °C : 6.3 , 55 °C : 1.5 30 °C : 4.0	60 °C : 13.8 , 90 °C : 5.1 70 °C : 9.7 , 100 °C : 3.8 75 °C : 8.2 , 110 °C : 2.8 80 °C : 7.0 , 120 °C : 2.2 85 °C : 5.9 , 130 °C : 1.7	
Relay	—		FMCA - 1SZ607	
Coil rated	V	—	AC 220 - 240 V	
Contact rating	V.A	—	AC 440 V, 13 A	
Coil resistance (at 25 °C)	Ω	—	—	
Solenoid control valve or coil				
Solenoid control valve	HKV - 30D16		CHV - 0301	CHV - 0401
Solenoid coil	EKV - MOZS559E0		CHV - 01AJ504D1	
Float switch	FS - 3502 - 204		—	
Rated (Contact rated)	AC 230 V, 50 W		—	

1-4 Dimensional Data

(A) Indoor Unit : 25, 36, 48 Type

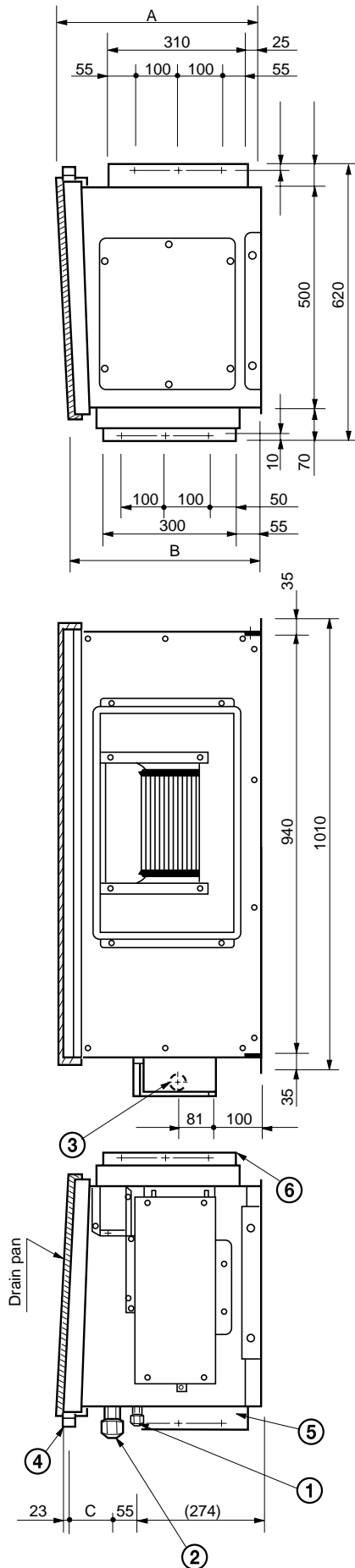

	A	B	C
25, 36 type	420	395	68
48 type	450	425	98

	25 type	36, 48 type
Ref. gas line	∅ 15.88	∅ 19.05
Ref. liquid line	∅ 6.35	∅ 9.52

- ① Refrigerant liquid line
- ② Refrigerant gas line
- ③ Power supply entry
- ④ Drain connection (20 A / VP20)
- ⑤ Duct connection for suction
- ⑥ Duct connection for discharge

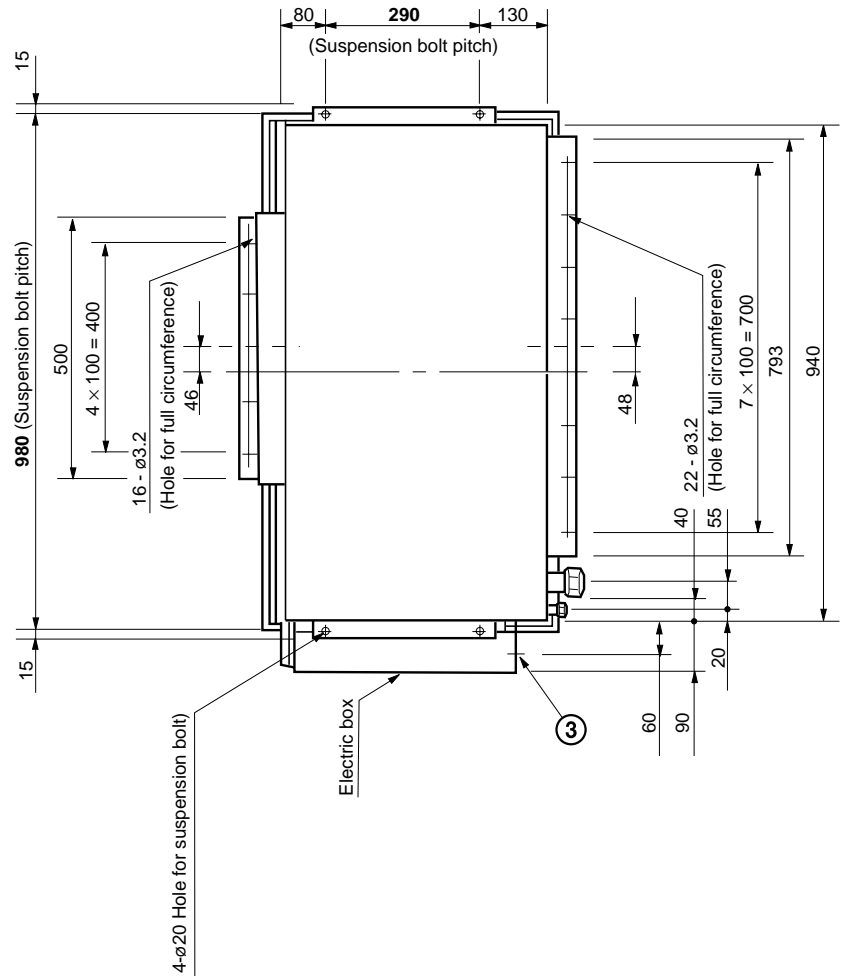
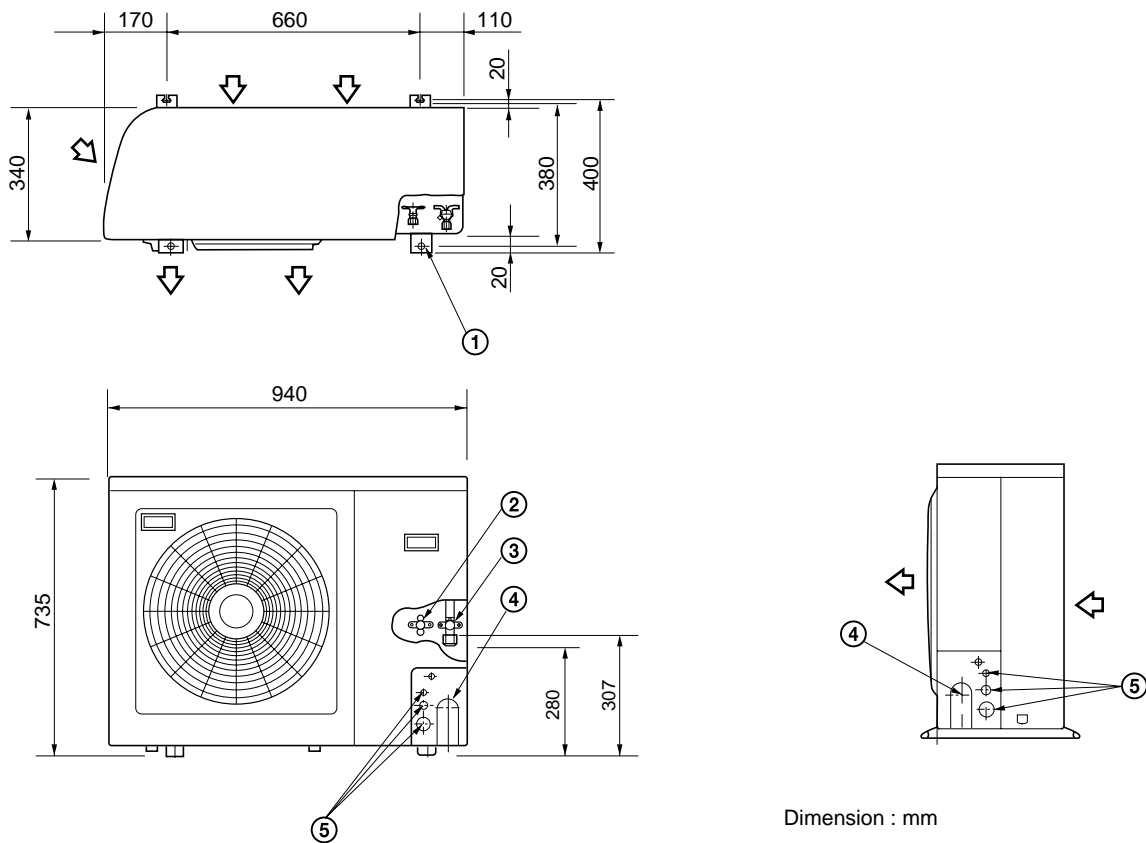

Fig. 1

**(B) Outdoor Unit :SPW-C253GH5
SPW-C253GH8**



Dimension : mm

- ① Hole for anchor bolt (4- ϕ 13)
- ② Refrigerant tube joint (narrow tube)
Flare connection 1/4 in (6.35 mm)
- ③ Refrigerant tube joint (wide tube)
Flare connection 5/8 in (15.88 mm)
- ④ Refrigerant tubing inlet
- ⑤ Power supply inlet

0411_C_S

Fig. 2



**(B) Outdoor Unit :SPW-C363GH8
SPW-C483GH8**

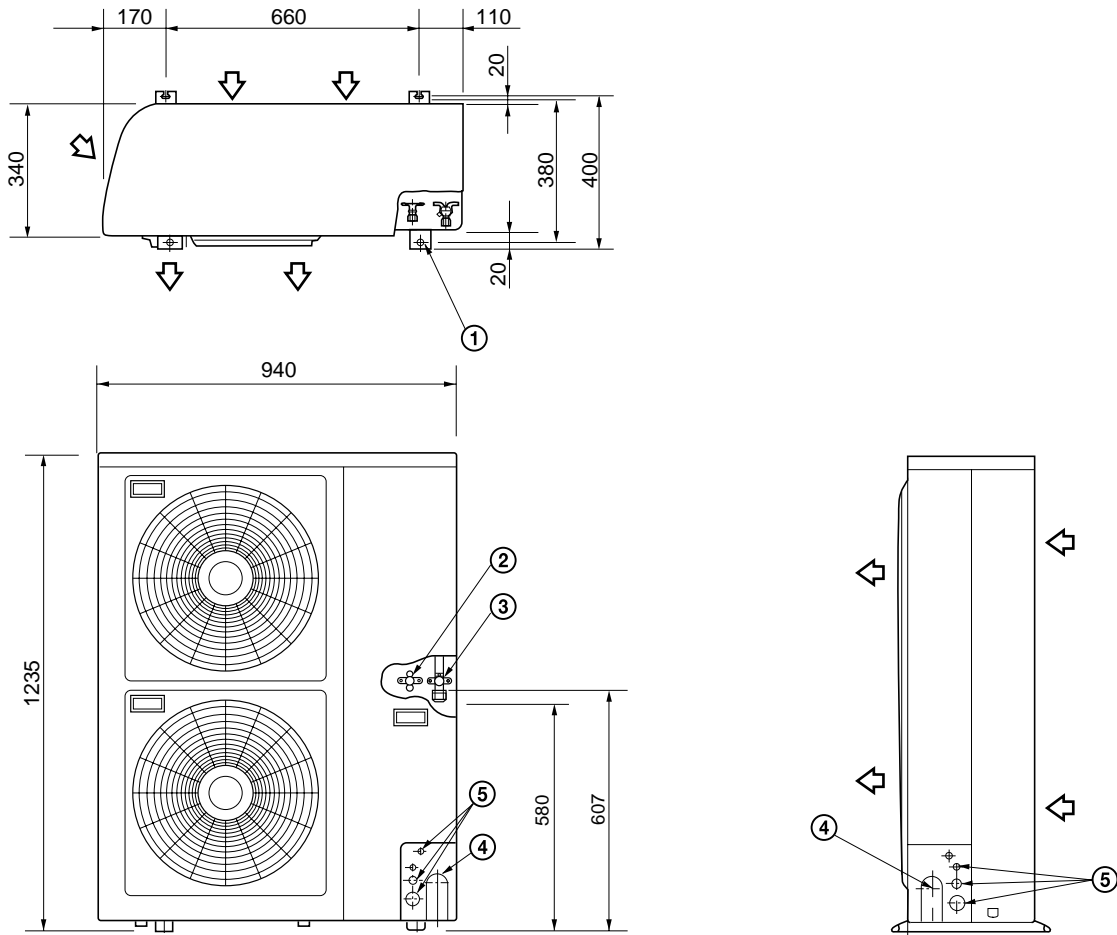

Dimension : mm

- ① Hole for anchor bolt (4- ϕ 13)
- ② Refrigerant tube joint (narrow tube)
Flare connection 3/8 in (9.52 mm)
- ③ Refrigerant tube joint (wide tube)
Flare connection 3/4 in (19.05 mm)
- ④ Refrigerant tubing inlet
- ⑤ Power supply inlet

0412_C_5

Fig. 3

1-5 Refrigerant Flow Diagram

**Outdoor Unit : SPW-C253GH5
SPW-C253GH8**

Indoor Unit : SPW-D253GH56

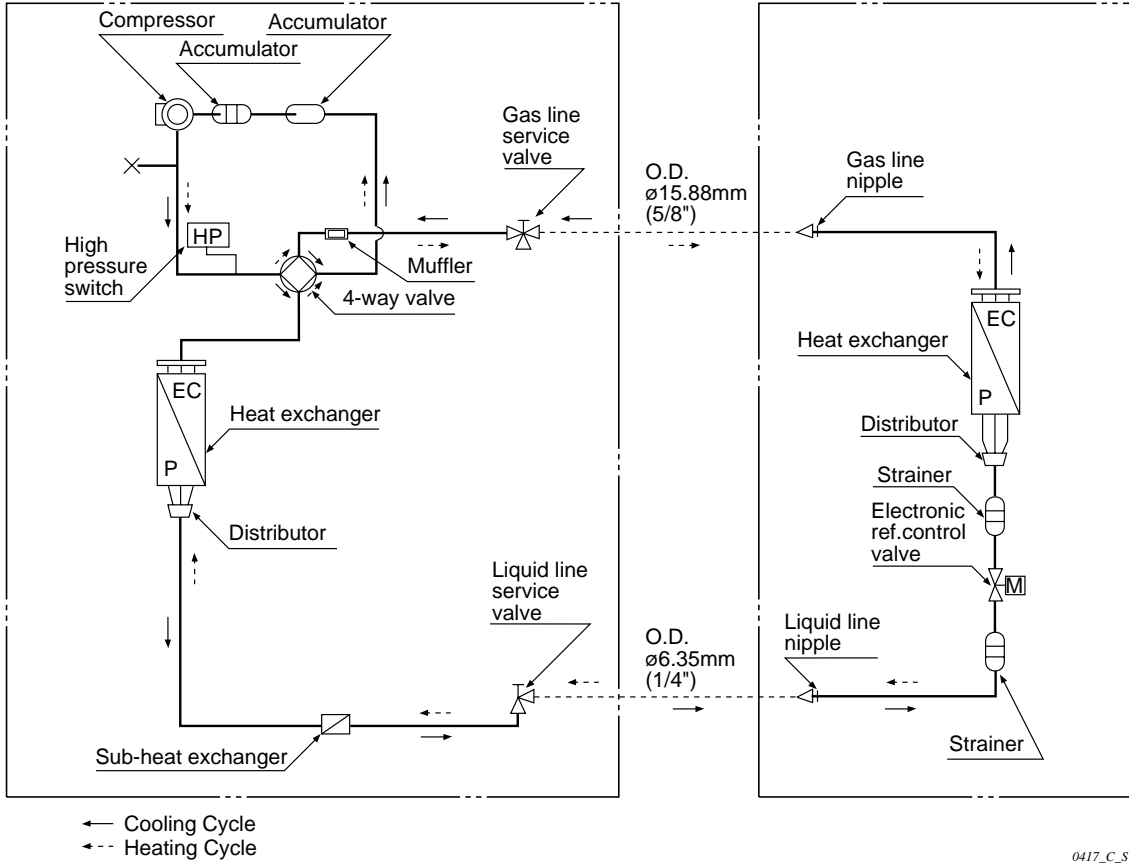

Fig. 4

1

**Outdoor Unit : SPW-C363GH8
SPW-C483GH8**

**Indoor Unit : SPW-D363GH56
SPW-D483GH56**

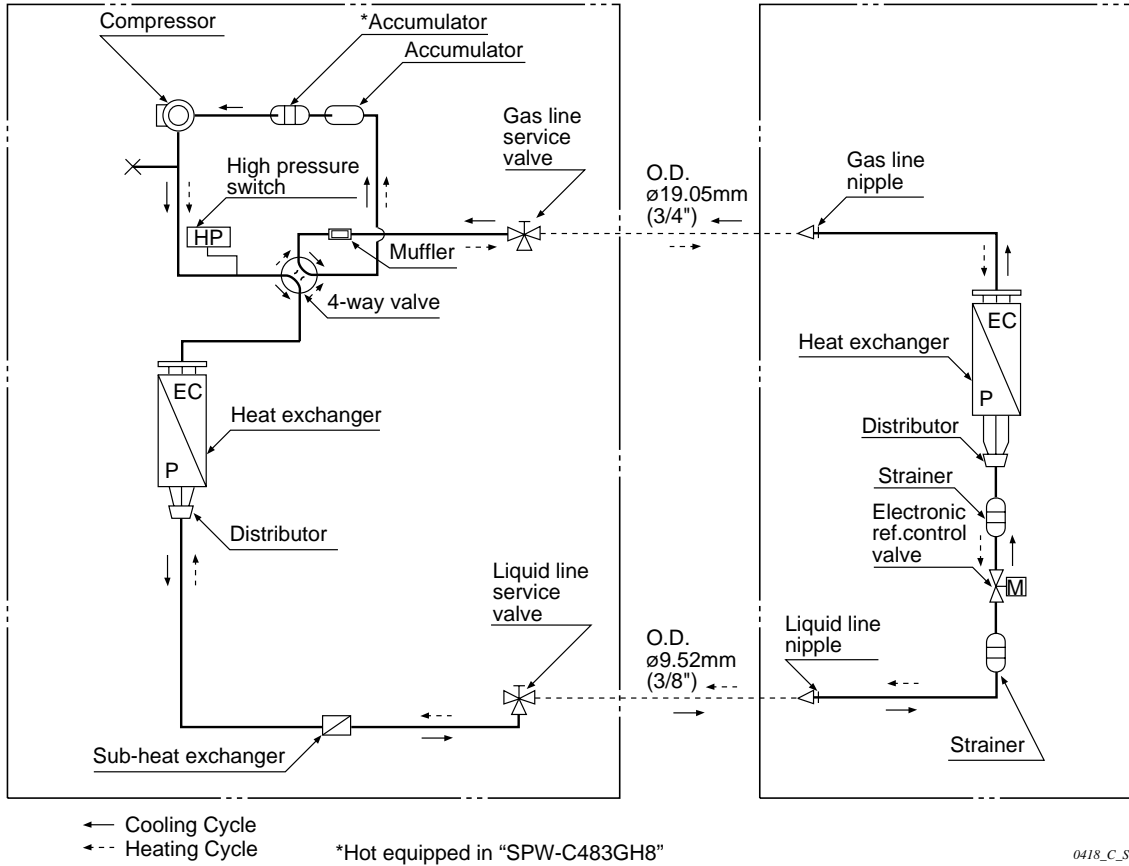

Fig. 5

1-6 Operating Range

	Temperature	Indoor air intake temp.	Outdoor air intake temp.
Cooling	Maximum	35°C DB / 25°C WB	45°C DB
	Minimum	17°C DB / 14°C WB	-5°C DB
Heating	Maximum	27°C DB / — WB	24°C DB / 18°C WB
	Minimum	16°C DB / — WB	-15°C DB / — WB

2. PROCESSES AND FUNCTIONS

2-1	Room Temperature Control	26
	(A) Cooling	26
	(B) Heating	27
2-2	Cold Draft Prevention (Heating Cycle)	28
2-3	Automatic Fan Speed (Indoor Unit)	29
	(A) Cooling	29
	(B) Heating	29
2-4	Outdoor Fan Speed Control	30
	(A) Cooling	30
	(B) Heating	30
2-5	Freeze Prevention (Cooling)	31
2-6	Condensing Temperature Control (Cooling)	32
2-7	Overload Protection (Heating)	33
2-8	Discharge Temperature Control (Cooling and Heating)	34
2-9	Auto. Mode for Automatic Heating/Cooling Switching	34
2-10	Defrosting Control, Outdoor Heat Exchanger Coil (Heating)	36
2-11	4-Way Valve, Solenoid Control	37
	(A) Normal Control Mode	37
	(B) AUTO Control Mode	38
2-12	Automatic Restart after Power Interruption	38
2-13	Electronic Refrigerant Control Valve	39
2-14	Compressor Discharge Gas Temperature	39
	(A) Cooling	39
	(B) Heating (Except During Defrosting)	39
2-15	Compressor Current Detection Circuit	40
2-16	Dehumidifying Operation	41
2-17	Electronic Refrigerant Control Valve Control	42
2-18	Voltage Detection Control	43

2-1 Room Temperature Control

The unit adjusts room temperature by turning the outdoor unit's compressor ON and OFF. This process is controlled by the **thermostat** located in the indoor unit.

The figures on this and the next page show how each part of the system performs as the room temperature changes and the thermostat activates the compressor to start (**thermo ON**) or stop (**thermo OFF**). Fig. 1 shows about the cooling cycle, and Fig. 2 shows about the heating cycle.

(A) Cooling

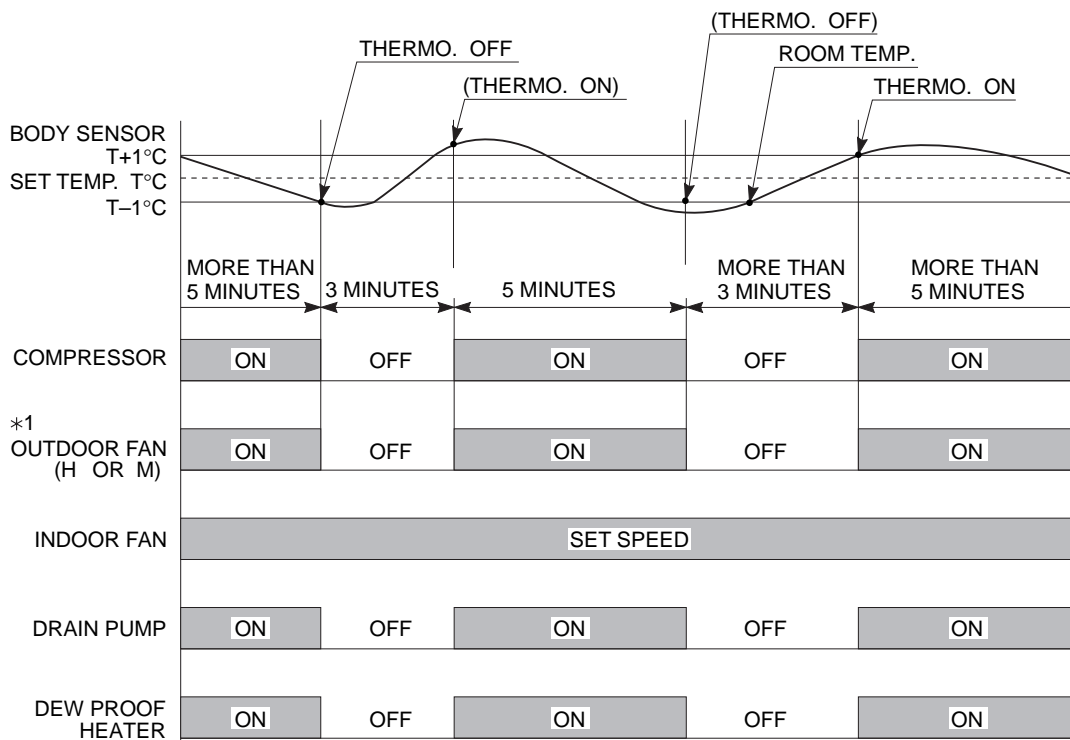

*1. Refer to 2-4 Outdoor Fan Speed Control

0671_X_S

Fig. 1

Chart Summary and Explanations

- Once the compressor **starts**, it keeps running for 5 minutes.
- Once the compressor **stops**, it will not start running again for 3 minutes.
- If you **change** the operation mode (**HEAT**, **DRY**, **COOL**, or **FAN**) during the cooling cycle, the control circuit **stops** the compressor for 3 minutes.
- For 5 minutes after the compressor is first turned on, and for 3 minutes after it is turned off, the compressor is not controlled by the room sensor.
- Thermo ON:** When room temperature rises 1°C (2°C when set on body sensor) above the set temperature T° , ($T^{\circ}+1^{\circ}\text{C}$ or $T^{\circ}+2^{\circ}\text{C}$ when set on body sensor):
Compressor → **ON**
- Thermo OFF:** When the room temperature is -1°C below the set temperature T° :
Compressor → **OFF**

(B) Heating

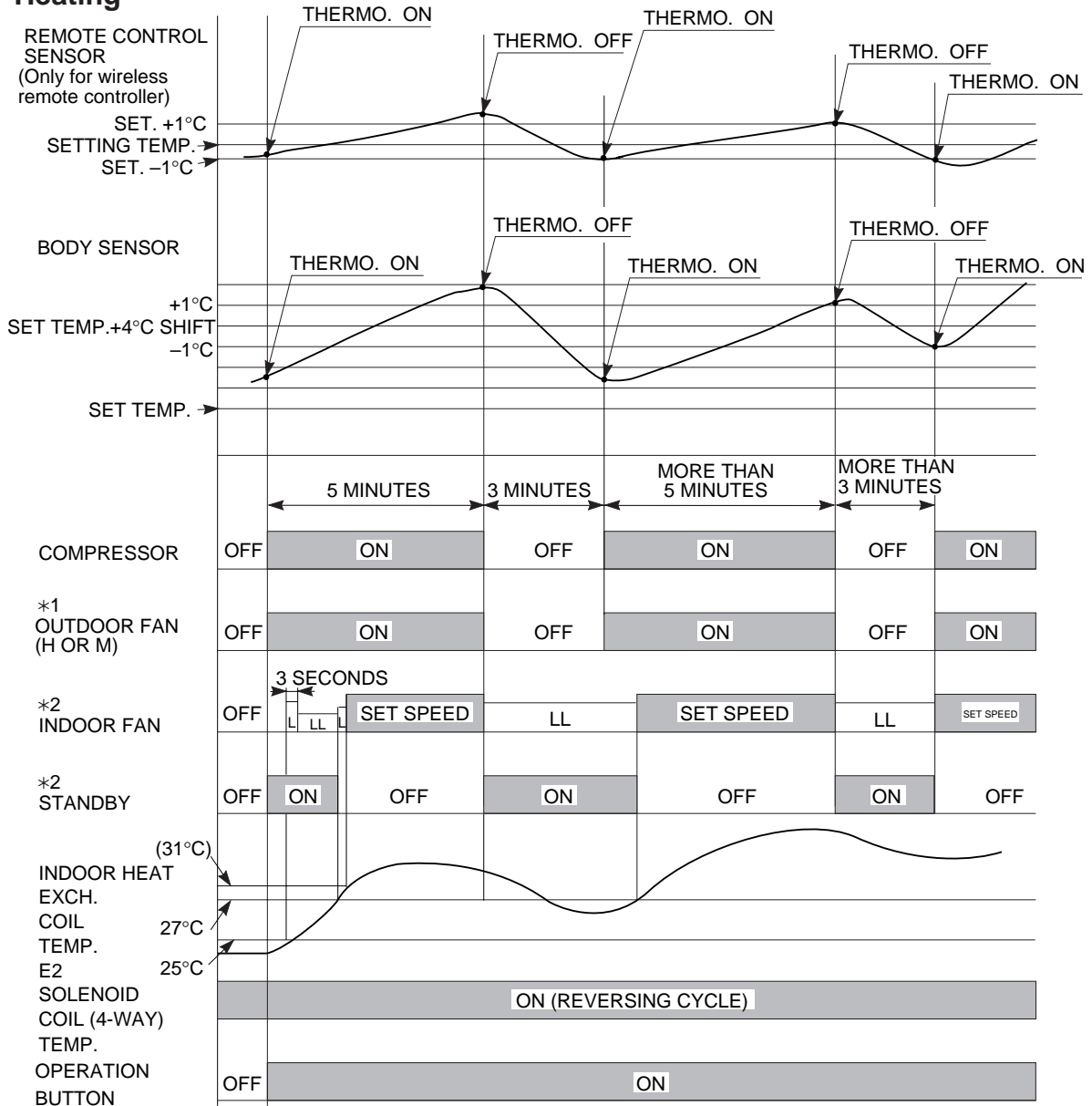

*1. Refer to 2-4 Outdoor Fan Speed Control
 *2. Refer to 2-2 Cold Draft Prevention (Heating)

0672_X_S

Fig. 2

Chart Summary and Explanations

- ❑ Once the compressor starts, it keeps running for 5 minutes.
 - ❑ Once the compressor stops, it will not start running again for 3 minutes.
 - ❑ If you change the operation mode (HEAT, DRY, COOL or FAN) during the heating cycle, the control circuit **stops** the compressor for **3 minutes**.
 - ❑ For 5 minutes after the compressor is first turned on, and for 3 minutes after it is turned off, the compressor is not controlled by the room sensor.
- When set on remote control sensor
- Thermo ON:** When room temperature is -1°C below the set temperature T° .
 Compressor → ON
- Thermo OFF:** When the room temperature is 1°C above the set temperature T° , ($T^{\circ} + 1^{\circ}\text{C}$)
 Compressor → OFF
- When set on body sensor
- NOTE:** In case of Body sensor, operating temperature is shifted to setting temperature $+4^{\circ}\text{C}$.



2-2 Cold Draft Prevention (Heating Cycle)

The cold draft prevention function controls indoor fan speed so a strong draft of cold air will not blow out before the indoor heat exchange coils have warmed up.

- ❑ STANDBY shows on the remote controller when the indoor fan speed is LL (very low) or OFF. This condition occurs in the following 3 cases:
 - During Thermo OFF (refer to 2-1 B). Room Temperature Control, Heating)
 - During the defrosting operation (refer to 2-10 Defrosting Control, Heating)
 - Until either the coil temperature E2 reaches 27°C or when a maximum of 6 minutes has past.
- ❑ The indoor fan motor operates in L instead of LL for 3 seconds as it starts to give the fan an initial boost.

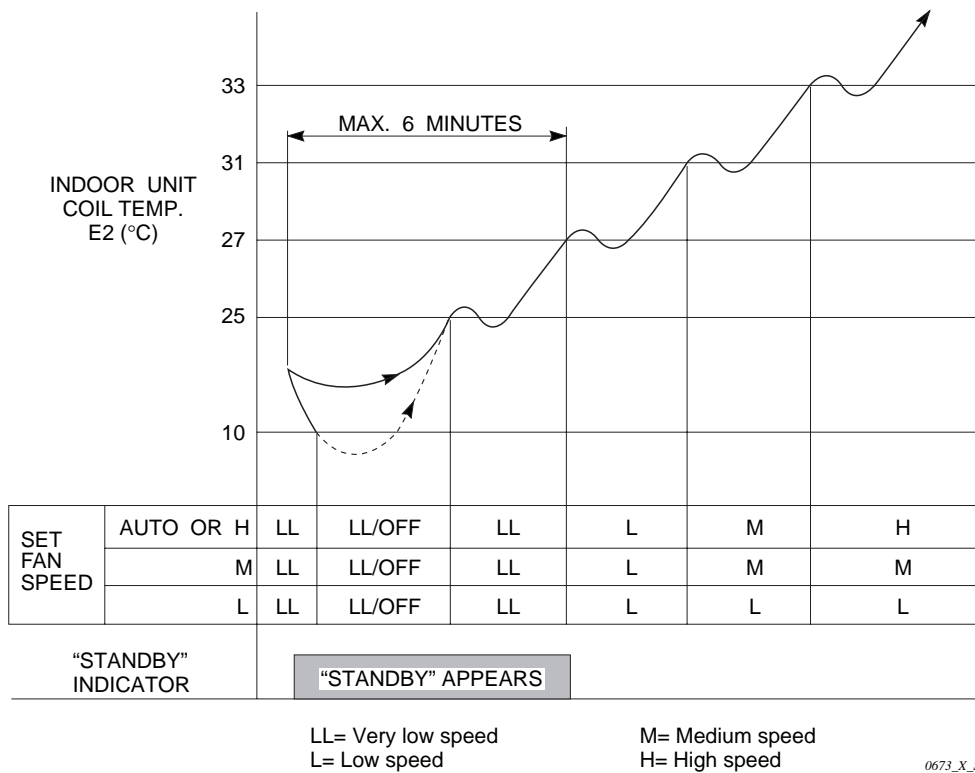

Fig. 3

Chart Summary and Explanations

- ❑ The main idea of this chart is to show that the indoor fan speed increases and gets closer to the set fan speed as the coil temperature **E2** rises.
- ❑ The indoor unit's coil temperature is taken from sensor **E2** located in the middle of the indoor heat exchange coil.
- ❑ The dotted line shows that the indoor fan motor is **OFF**. When the temperature at sensor **E2** falls below 10°C, the indoor fan motor stops running.

2-3 Automatic Fan Speed (Indoor Unit)

By pressing the FAN SPEED button on the remote controller, the fan speed can be set at one of four steps: AUTO., HI., MED., or LO. When set at AUTO. the indoor unit fan speed will be automatically adjusted to the room temperature as the two charts shown below.

(A) Cooling

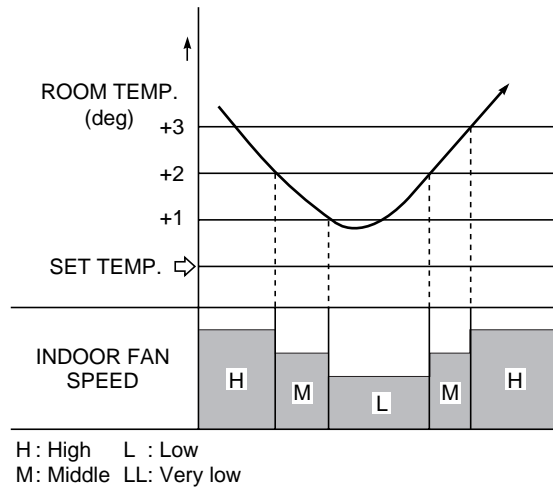

Fig. 4

Chart Explanations and notes

- When the fan speed changes, it keeps the speed step for at least 3 minutes, even if the temperature changes to another speed step during the time.

(B) Heating

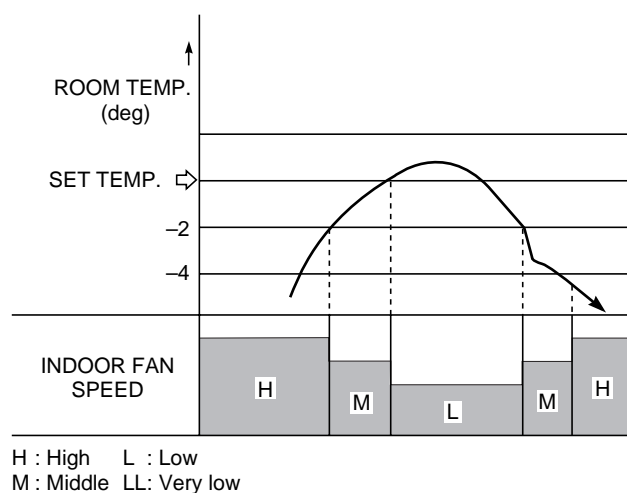

Fig. 5

Chart Explanations and notes

- When the fan speed changes, it keeps the speed step for at least 1 minute, even if the temperature changes to another speed step during the time.

2-4 Outdoor Fan Speed Control

To optimize the performance of air conditioner, the outdoor fan speed is selected automatically according to the outdoor temperature.

- ❑ Note that in both **Cooling** and **Heating** modes, the fan comes on at first at high speed (H mode) for 5 seconds. Since outdoor conditions sometimes make it difficult for the fan to start, this sudden surge of power may be necessary.
- ❑ The outdoor fan operates in H mode for 3 minutes after the compressor stops (excluding defrosting operation period).
- ❑ Charts below show how the outdoor fan speed changes with the change in outdoor temperature.

(A) Cooling

Outdoor unit coil temperature [C2]	Outdoor fan motor (FMo)
Not less than 25° c	H
Not more than 25° c	M

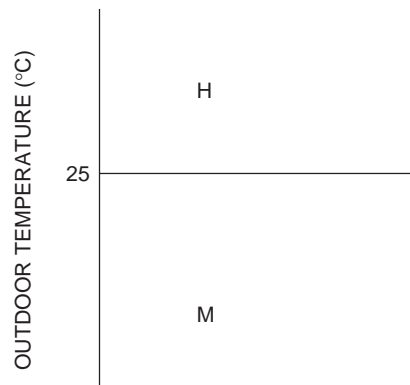

Fig. 6

(B) Heating

Outdoor coil temperature [C2]	Outdoor fan motor (FMo)
Not less than 14° c	M
Not more than 14° c	H

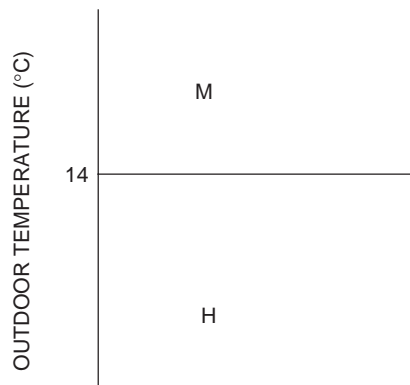

Fig. 7

2-5 Freeze Prevention (Cooling)

Freeze Prevention keeps the indoor heat exchange coil from freezing. Freezing reduces the efficiency of the unit, and frost buildup on the coil blocks cool air circulation from the indoor unit's fan.

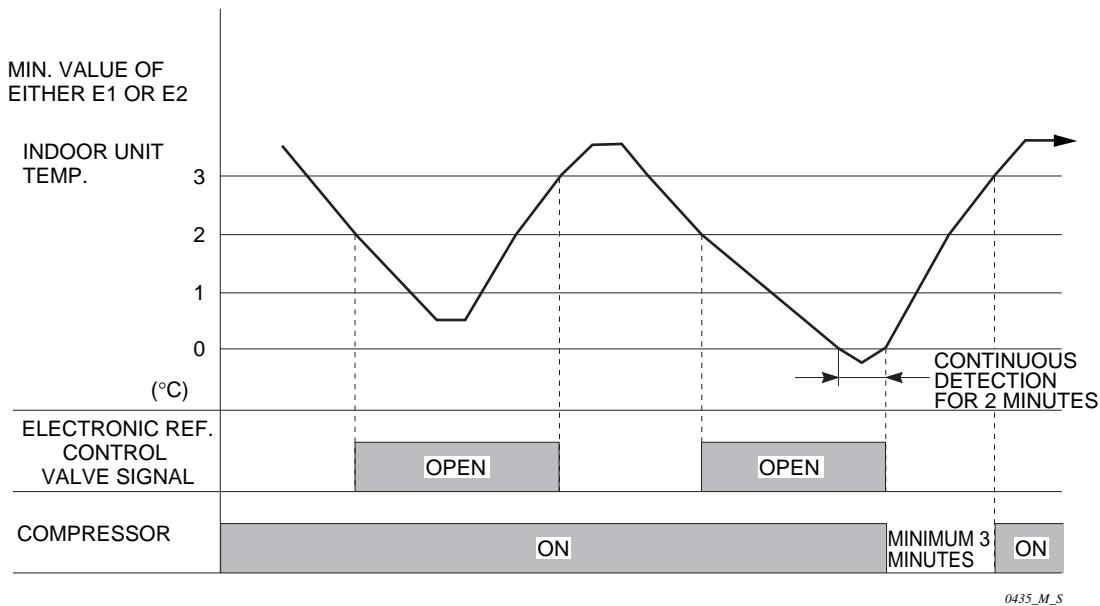

Fig. 8

Note: Freeze prevention is controlled by the temperature at the indoor heat exchanger coil as sensed by either sensor **E1** (located at the entrance of the coil) or sensor **E2** (located on the middle of the coil). Freeze prevention cycle is controlled by the lower temperature sensed at either of the two sensors.

Chart Explanations and notes

- ❑ This chart shows when the **electronic refrigerant control valve** opens to regulate the temperature of the indoor unit coil to prevent freezing.
- ❑ If the refrigerant control is not effective and the temperature continues to drop and stays below 0°C for 2 minutes continuously, the control circuit stops the compressor. The compressor does not start again until the temperature rises above 3°C. The compressor stops for 3 minutes minimum.

2-6 Condensing Temperature Control (Cooling)

Condensing temperature is controlled by the outdoor heat exchanger coil temperature as sensed by sensor **C2**.

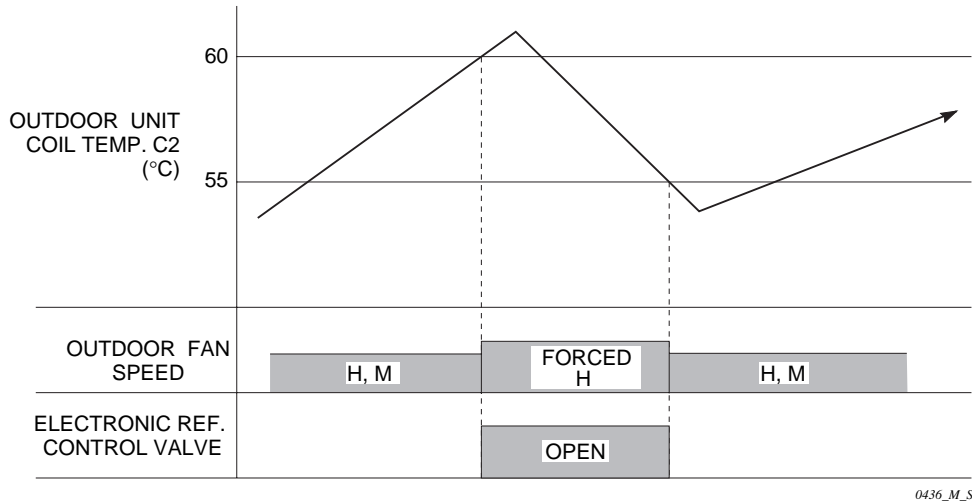

0436_M_S

Chart Explanations and notes

- ❑ This chart shows how the outdoor fan speed and the electronic refrigerant control valve react to coil temperature to control condensing temperature.
- ❑ Sensor **C2** is located in the middle of the outdoor unit heat exchange coil.
- ❑ When **C2** rises above 60°C the electronic refrigerant control valve opens at 50 steps/30 seconds, and the outdoor fan speed is forced to change to high (H) until **C2** falls below 55°C.

Fig. 9

2-7 Overload Protection (Heating)

This function prevents the air conditioner from overloading.

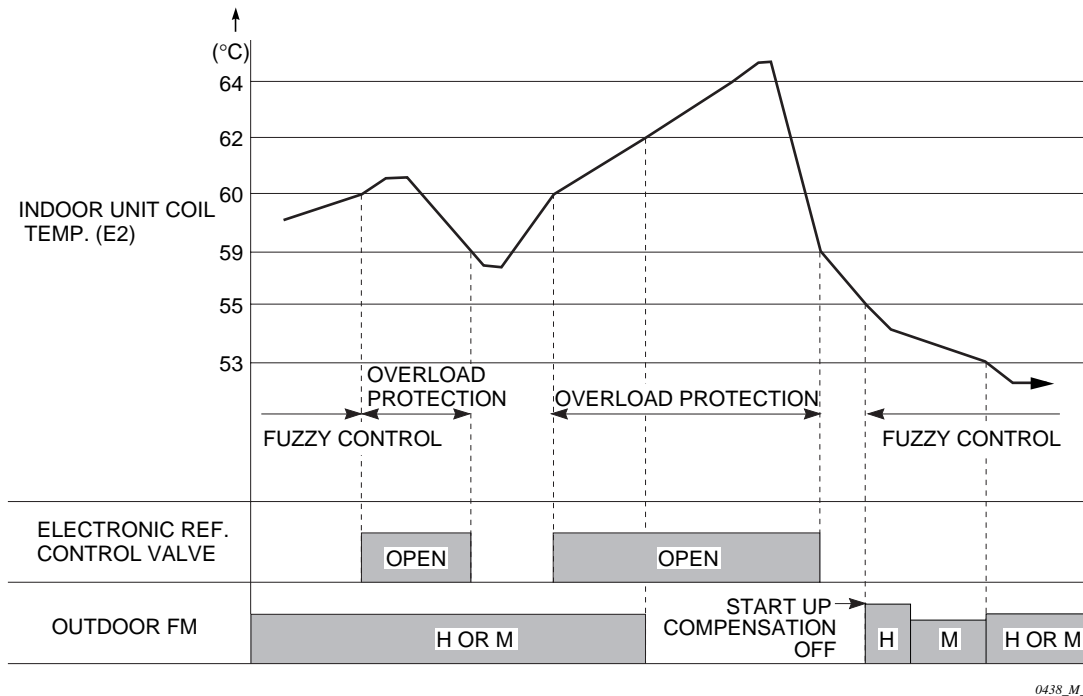

0438_M_S

Fig. 10

Chart Explanations and notes

- ❑ This chart shows how the outdoor fan speed and the electronic refrigerant control valve react to coil temperature to keep the indoor heat exchanger coil from overloading.
- ❑ When sensor **E2** rises above 60°C the electronic refrigerant control valve opens at 50 steps/30 seconds until **E2** falls below 59°C.
- ❑ Sensor **E2** is located in the middle of the indoor unit heat exchange unit.
- ❑ When sensor **E2** rises above 62°C, the control circuit stops the outdoor fan motor till the temp. drops to 55°C
- ❑ Fuzzy control controls the electronic refrigerant control valve.

2-8 Discharge Temperature Control (Cooling and Heating)

This function prevents the compressor motor from burnout by overheating.

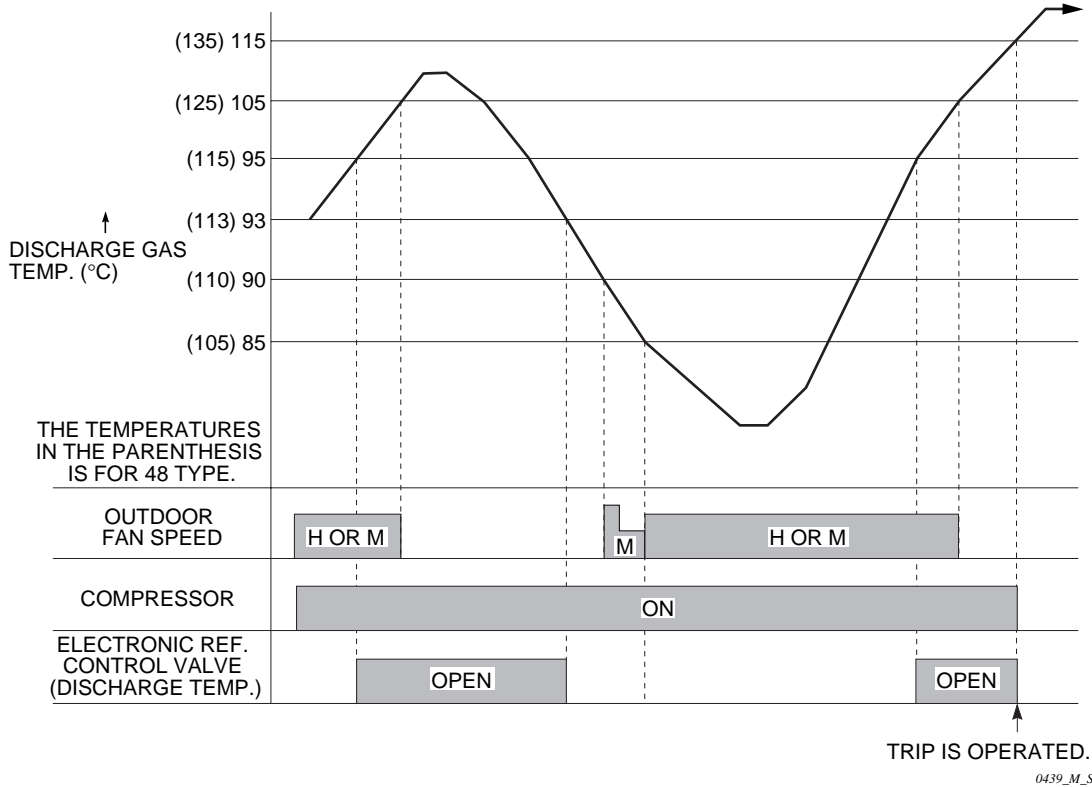

Fig. 11

Chart Summary and Explanations

- ❑ Discharge temperature is sensed by **TH8** (discharge gas sensor).
- ❑ When the temperature rises **above 95°C** the electronic refrigerant control valve opens at 50 steps/30 seconds until the temperature falls **below 93°C**.
- ❑ During **HEATING** operation, when the temperature rises **above 105°C**, the control circuit stops the outdoor fan motor until the temperature falls below 90°C. Please note that this control does not function during **COOLING** operation.
- ❑ For both **COOLING** and **HEATING** modes, if the temperature reaches **115°C** (135°C for 48 type) the operation shuts down and alarm **P3** appears on the remote controller.
- ❑ The outdoor fan speed is controlled on discharge temp. at heating mode.

2-9 Auto. Mode for Automatic Heating/Cooling Switching

- ❑ When the AUTO mode is selected, the microprocessor calculates the difference between the set temperature and the room temperature, and automatically switches to the COOLING or HEATING mode to maintain the desired temperature.

Room temp. \geq Set temp. \rightarrow COOLING

Room temp. $<$ Set temp. \rightarrow HEATING

This means that if the room temperature is **higher or equal to** the set temperature, **COOLING** operation starts. If the room temperature is **lower** than the set temperature, **HEATING** operation starts.

2-9 Auto. Mode for Automatic Heating/Cooling Switching

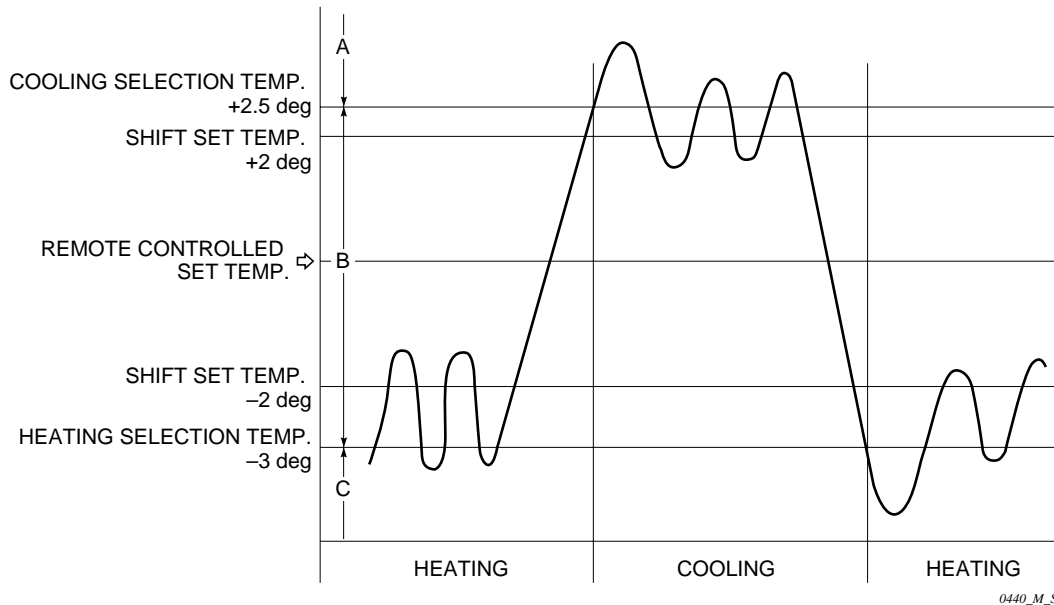

Fig. 12

Chart summary and Explanations

- ❑ This chart shows how the Operation Mode (**COOLING** or **HEATING**) is determined by the microprocessor taking the room temperature into consideration. It also shows the temperature points at which the cooling or heating mode is switched, when the AUTO mode is selected.
- ❑ After operation starts, the set temperature shifts automatically by +2 deg. at cooling and by -2 deg. at heating. For example, if cooling is selected, the set temperature changes from 20° C to 22° C.
(The display of the remote controller remains 20° C.)
- ❑ The change of the operation mode (heating to cooling, cooling to heating) by the change of the room temperature during the operation is as follows.
Heating to Cooling; Room temp. \geq Shifted temp + 0.5 deg.
Cooling to Heating; Room temp. \leq Shifted temp -1.0deg.
For example, if the room temperature rises above 22.5 °C (=22+0.5) during the cooling operation at the room temperature 20° C set by the remote controller, the operation changes to cooling. When the room temperature lowers below 17° C (=18-1.0) thereafter, the operation changes to heating again.
- ❑ In heating operation, using the body sensor, room temperature control is designed so that room air temp. is sensed as 4 deg. lower than suctioned air at indoor unit taking into account of the temperature gap between upper part and lower part of the room.
- ❑ Within 10 minutes after the compressor turns OFF, the operation does not change to cooling (heating), even when the room temperature changes from C to A (A to C).
- ❑ When switching from cooling (heating) to heating (cooling), the actuation of the 4 way valve will delay about 30-50 seconds after the compressor turns ON.

2-10 Defrosting Control, Outdoor Heat Exchanger Coil (Heating)

When the outdoor temperature is low, frost may form on the outdoor heat exchanger coil. When this occurred, the defrosting system operates. The microprocessor in the outdoor unit monitors the relationship between the temperature of the outdoor heat exchanger coil and the outdoor temperature so it can defrost when necessary.

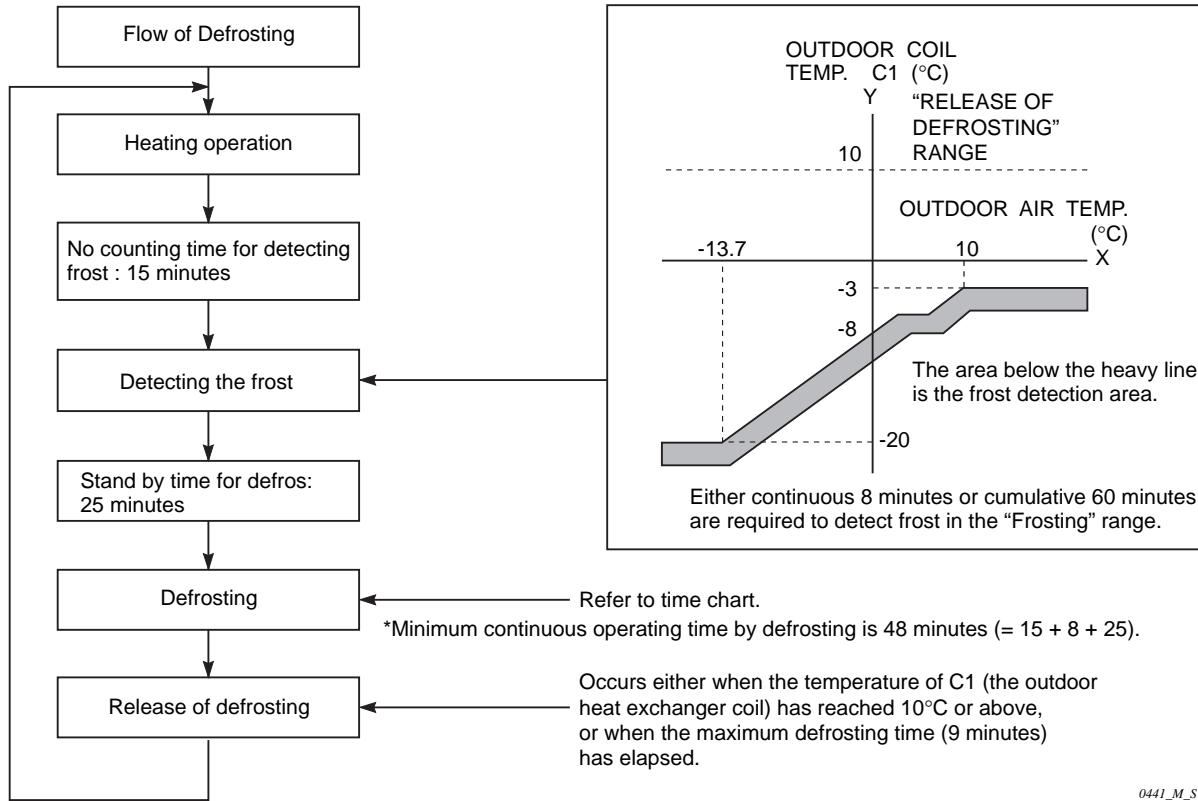

0441_M_S

Fig. 13

Time Chart for Defrosting

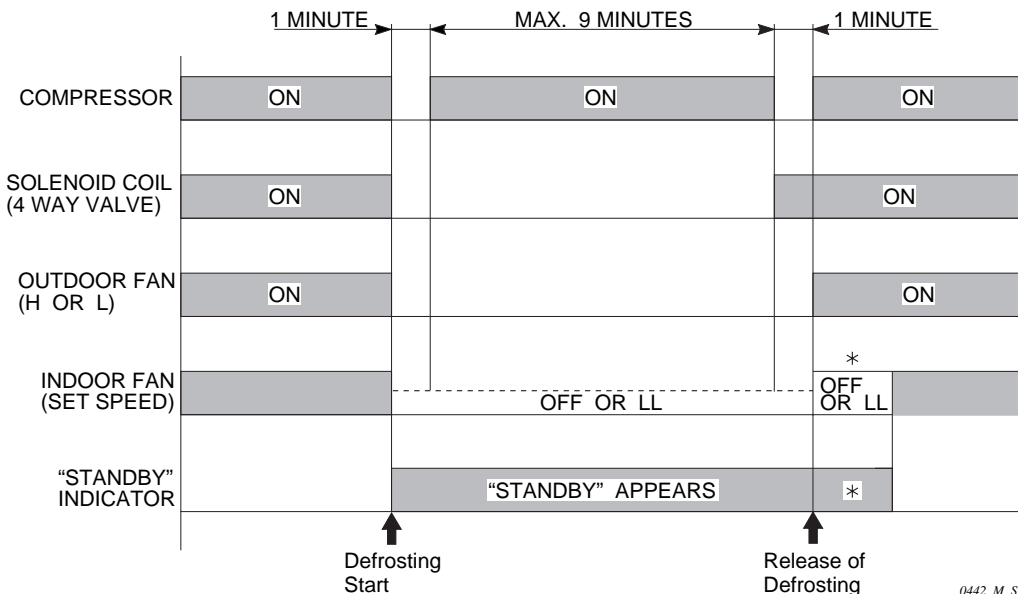

0442_M_S

Fig. 14

- During the defrost cycle, **STANDBY** appears on the remote controller.
- *.....**Cold Draft Prevention** may operate occasionally

2-11 4-Way Valve, Solenoid Control

The basic function of the 4-way valve is to direct the refrigerant in the correct direction according to the Operation Mode (**COOLING** or **HEATING**) selected.

The following two charts show conditions of the controls and functions listed in the left hand column when the solenoid is **ON** or **OFF**. Chart (A) on this page shows the relationships when the temperature control is in **NORMAL** mode, and Chart (B) on the next page shows the relationships when the remote controller is set to **AUTO** mode.

(A) Normal Control Mode

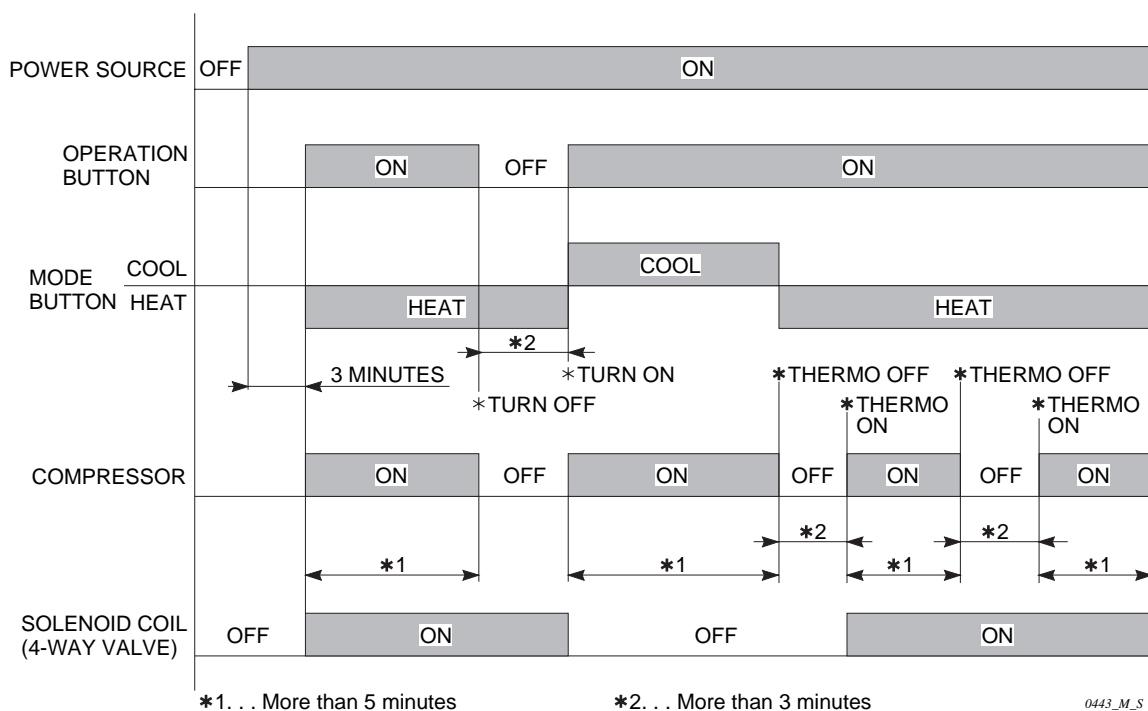

Fig. 15

Chart Summary and Explanations

- ❑ For the first 3 minutes after power is applied, the 4-way valve remains OFF and the compressor will not operate, even if the ON button is pushed.
- ❑ If the 4-way valve is turned OFF with the compressor operating, the air conditioner operates in COOLING mode. See Table below.
- ❑ If the 4-way valve is turned ON with the compressor operating, the air conditioner operates in HEATING mode. See Table below.

Operation Mode	4-way valve solenoid	Compressor
COOLING	OFF	ON
HEATING	ON	

(B) AUTO Control Mode

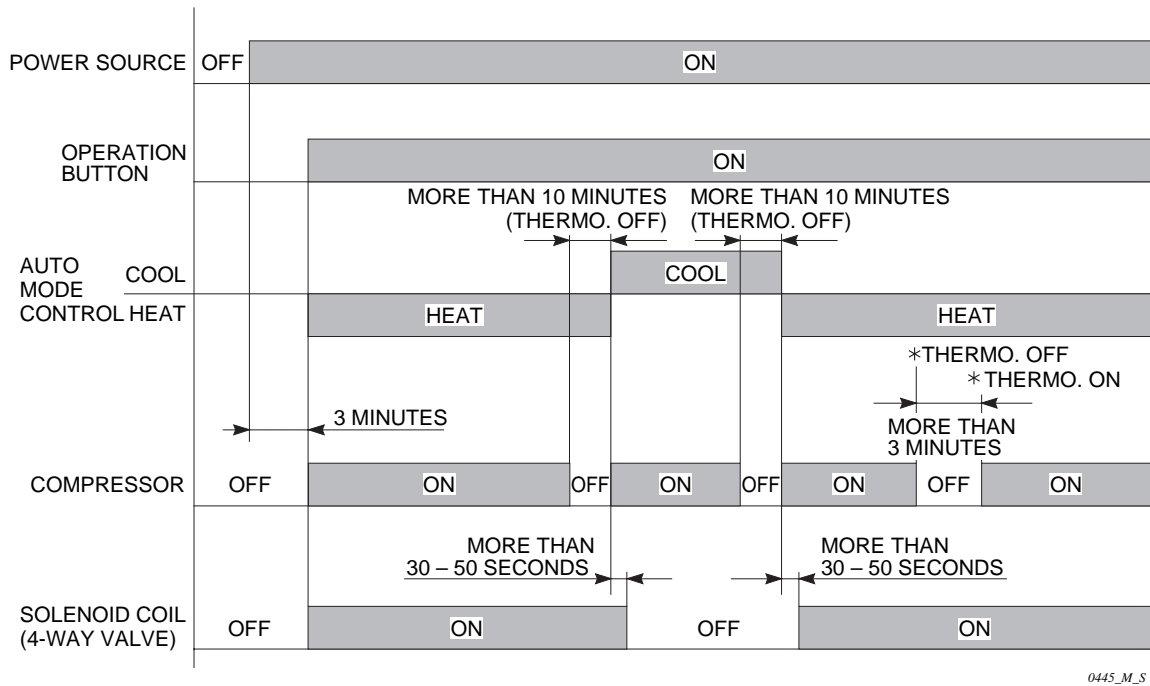
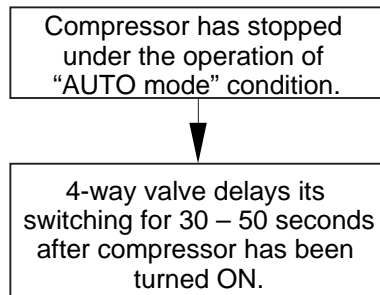

Fig. 16

When the Compressor has stopped while in **AUTO** mode, the 4-way valve switches on (heating) or off (cooling) within 1 minute according to the following conditions:



0446_M_S

Fig. 17

2-12 Automatic Restart after Power Interruption

This air conditioner has a power failure recovery function.

2-13 Electronic Refrigerant Control Valve

- ❑ This valve allows very precise and smooth control of the amount of refrigerant flow in the system. Since the valve is operated by a step motor, the control circuits can open or close it in very exact amounts, so the degree of heating or cooling can be changed by just a little, or changed very quickly or slowly.

(Completely close 0 step)

(Full open 480 step)

Model	Min. open		Max. open
	HEAT	COOL	
25 type	100 step	120 step	480 step
36 type	90 step	90 step	
48 type	100 step	110 step	

❑ Fuzzy Control

Fuzzy Control is a controlling system to control electronic refrigerant control valve using fuzzy logic. It regulates the functions of heating and cooling, as well as some of the processes inside the unit, by taking account of many different conditions of temperature, fan speed, etc. These control circuits work automatically to send just the right amount of refrigerant through the **Electronic Refrigerant Control Valve**.

2-14 Compressor Discharge Gas Temperature

(A) Cooling

Indoor temp. (°C)	20 – 25		26 – 28	29 – 32
Outdoor temp. (°C)	13 or below	14 – 16	27 – 35	36 – 43
Compressor discharge gas temp. (°C)	40 – 80	40 – 90	60 – 100	70 – 105

(B) Heating (Except During Defrosting)

Indoor temp. (°C)	18 – 21		22 – 25			26 – 30		
Outdoor temp. (°C)	0 or below	1 – 10	0 or below	1 – 10	11 – 21	0 or below	1 – 10	11 – 21
Compressor discharge gas temp. (°C)	40 – 80	50 – 90	40 – 90	50 – 100	60 – 105	50 – 90	60 – 100	70 – 105

- ❑ Operate the unit at least 30 minutes to stabilize the discharge temperature.
- ❑ The above discharge temperature was measured with a 15m tubing length. The temperature may vary with tubing length.

2-15 Compressor Current Detection Circuit

- ❑ The Compressor Current Detection Circuit detects the compressor current and, depending on the current range, can stop the compressor motor so it will not be damaged by overcurrent.
- ❑ Overcurrent can be caused by several factors, particularly mechanical seizing of the compressor or liquid backflow. Either of these conditions can hold the compressor to run, and thus drawing so much current that the motor can burn out.

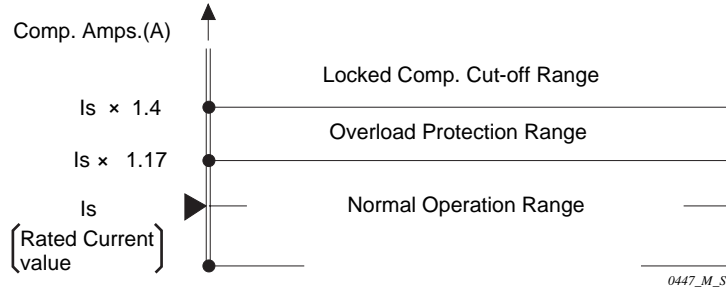

Fig. 18

2

Outdoor Model	Rated Current Value Is (A)	Overload Protection Is x 1.17 (A)	Locked Compressor Cut-off Is x 1.4 (A)
SPW-C253GH5	24.0	28.08	33.6
SPW-C253GH8	7.1	8.3	9.9
SPW-C363GH8	7.5	8.8	10.5
SPW-C483GH8	10.4	12.2	14.6

Chart Summary and Explanations

- ❑ **Overload Protection**
 - When the detected current is 1.17 – 1.4 times greater than the rated current value (Is) and continues for 30 seconds, both compressor and outdoor fan stop (Thermostat **OFF**).
 - After 3-minute pause, if the air conditioner is ready for Thermostat **ON**, it starts again. However, if the condition mentioned above repeats **twice within 30 minutes**, the remote controller displays the alarm message **H01, compressor overload**.
- ❑ **Locked Compressor Cut-off**
 - When the detected current is **1.4 times greater** than the rated current value (Is) and **continues for 2 seconds**, both compressor and outdoor fan stop (Thermostat **OFF**).
 - After 3-minute pause, if the air conditioner is ready for Thermostat **ON**, it starts again. However, if the condition mentioned above repeats **twice**, the remote controller displays the alarm message **H02, compressor locked**.
- ❑ **Failure of Compressor Current Detection**
 - When the Compressor Current Detection Circuit fails to detect the compressor current **within 2 seconds after compressor starts**, both compressor and outdoor fan stop (Thermostat **OFF**).
 - After 3-minute pause, if the air conditioner is ready for Thermostat **ON**, it starts again. However, when the circuit fails to detect the current twice in a row, the remote controller displays alarm message **H03, Failure of compressor Current Detection**.

2-16 Dehumidifying Operation

Dehumidifying operation uses the cooling cycle to remove moisture from the air, but by running an indoor fan at a low speed, to dehumidify without greatly lowering room temperature. In this mode, the microprocessor automatically controls the ON-OFF operation between +2 deg. and -2 deg. of the set temperature.

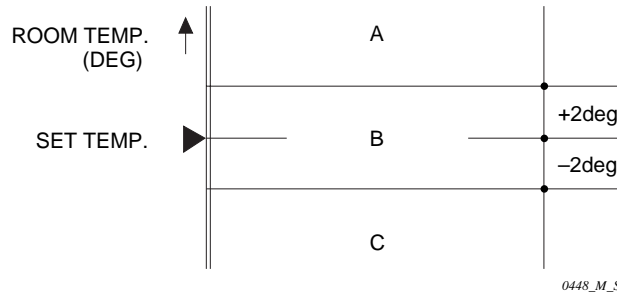

Fig. 19

- A range:** When the room temperature is in this range, cooling operation starts. However, when the temperature is below 18°C, the cooling operation does not start.
- B range:** When the room temperature is in this range, the air conditioner automatically repeats the dehumidifying cycle of 5 minutes **ON**, 3 minutes **OFF** – see Fig. 22 for details.
- C range:** When the room temperature is in this range, the microprocessor shuts off the air conditioner.

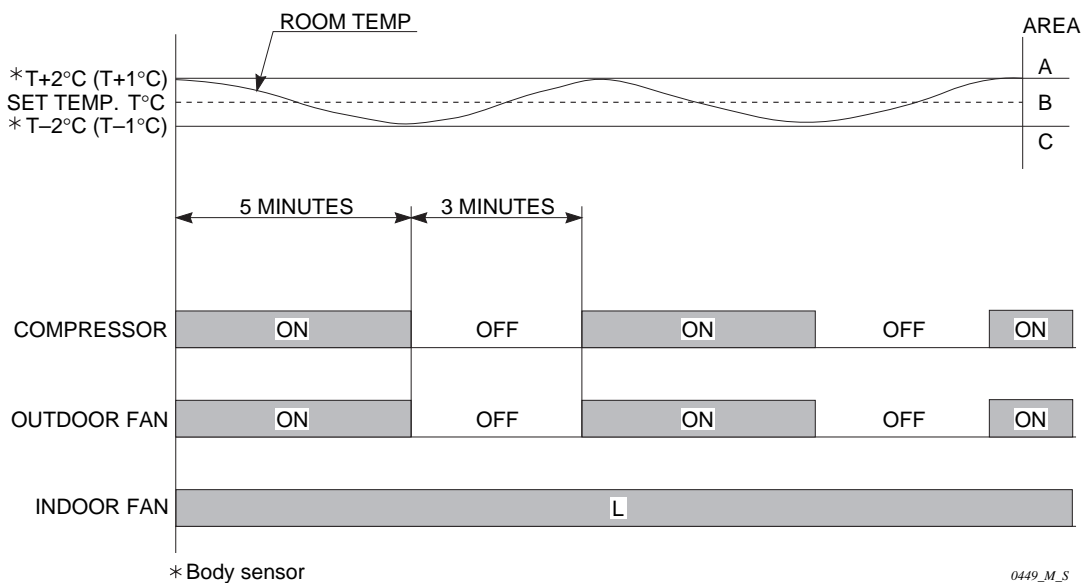

Fig. 20

- The indoor fan speed is automatically set to L and cannot be adjusted to M or H.
- When the set temperature is either 18 or 19°C, the set temperature is considered the same as 20°C.
- Room temperature is monitored every 8 minutes when it is in the B range to select the best operation mode.

2-17 Electronic Refrigerant Control Valve Control

The circulation volume of the refrigerant is controlled by a pulse type electronic control valve.

When the power is switched ON, the opening degree of the electronic control valve is controlled between 90 and 480 steps after setting the initial step at the time when the thermostat is ON.

Contents and Order of control

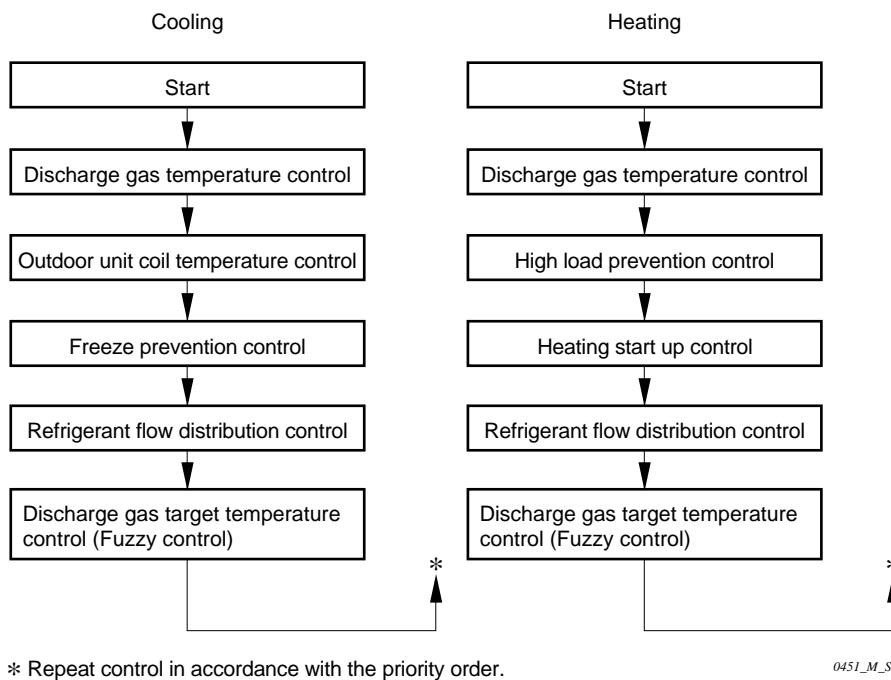

Even though the operation is performed every 30 seconds, the control of discharge gas temperature, high load prevention, outdoor unit coil temperature and freeze prevention activates when it occurs.

(1) Refrigerant flow distribution control

At the control of flexible combination (a plural number of indoor units are set), the opening degree of the electronic control valve is controlled by the indoor unit coil temperature.

Cooling: indoor unit coil E2 temperature (located at the middle of coil)

Heating: indoor unit coil E1 temperature (located at the outlet of coil)

(2) Fuzzy control (optimal refrigerant flow rate control)

By outputting the fuzzy estimation result corresponding to the fuzzy input variables (the indoor unit coil temp., the deviation between the actual discharge gas temp. and the target discharge gas temperature calculated from the outdoor unit coil temperature and the change thereof), the electronic refrigerant valve is controlled so that the unit can perform its maximum ability in accordance with the indoor and outdoor temperature conditions at the operation.

2-18 Voltage Detection Control

When the power voltage falls below 160 V (voltage between N phase and each phase) or rises above 260 V, the "P2" alarm is issued to protect the compressor and electrical components.

3. ELECTRICAL DATA

3-1	Indoor Unit (Electric Wiring Diagram, Schematic Diagram)	46
3-2	Outdoor Unit (Electric Wiring Diagram, Schematic Diagram)	52

3-1 Indoor Unit

① SPW-D253GH56

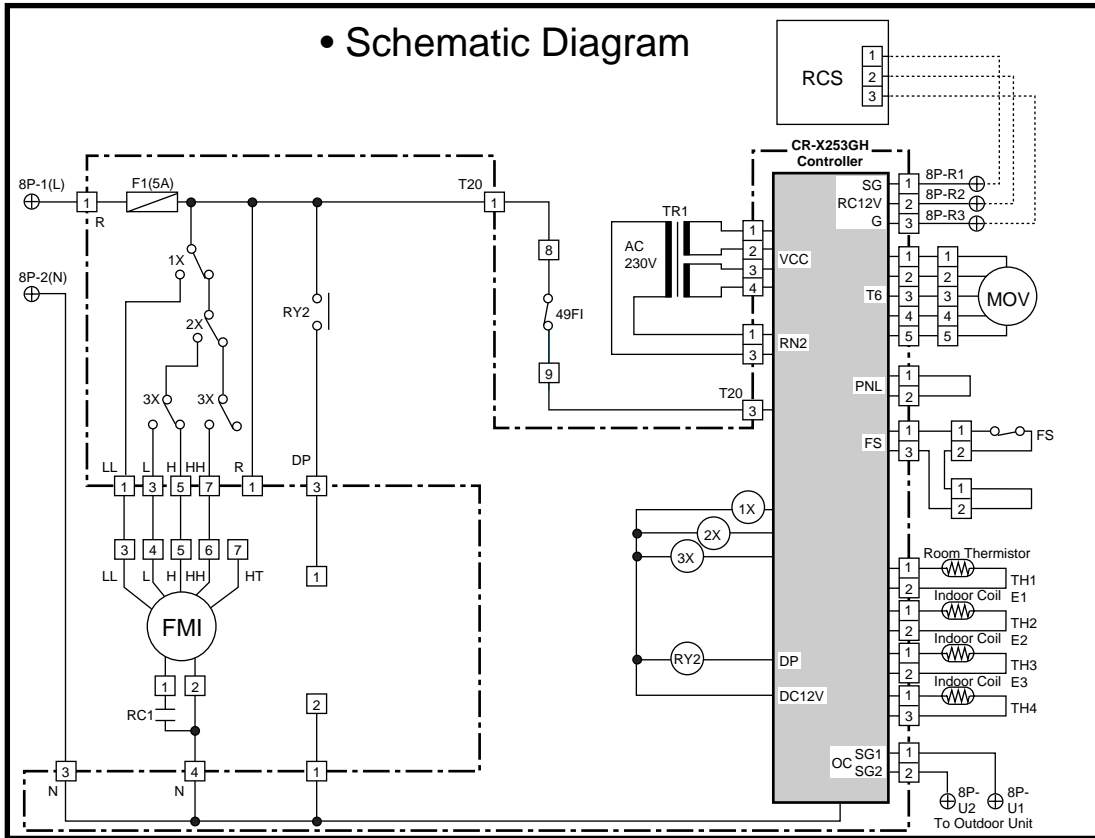

Symbols	Description	Symbols	Description
FMI	Indoor Fan Motor	TH4	Thermistor (Indoor Coil E3)
49FI	Indoor Motor Thermal Protector	CR-X253GH	Indoor Controller
RC1	Running Capacitor	⊕	Terminal Plate
F1	Fuse	□	Connector
TR1	Power Transformer	⊕	Terminal
1X-3X	Auxiliary Relay	FS	Float Switch
RY2	Auxiliary Relay		
MOV	Motor Operated Valve		
RCS	Remote Control Switch		
TH1	Room Thermistor		
TH2	Thermistor (Indoor Coil E1)		
TH3	Thermistor (Indoor Coil E2)		

© 854-2-5268-426-00-1 (D)

3-1 Indoor Unit

① SPW-D363GH56

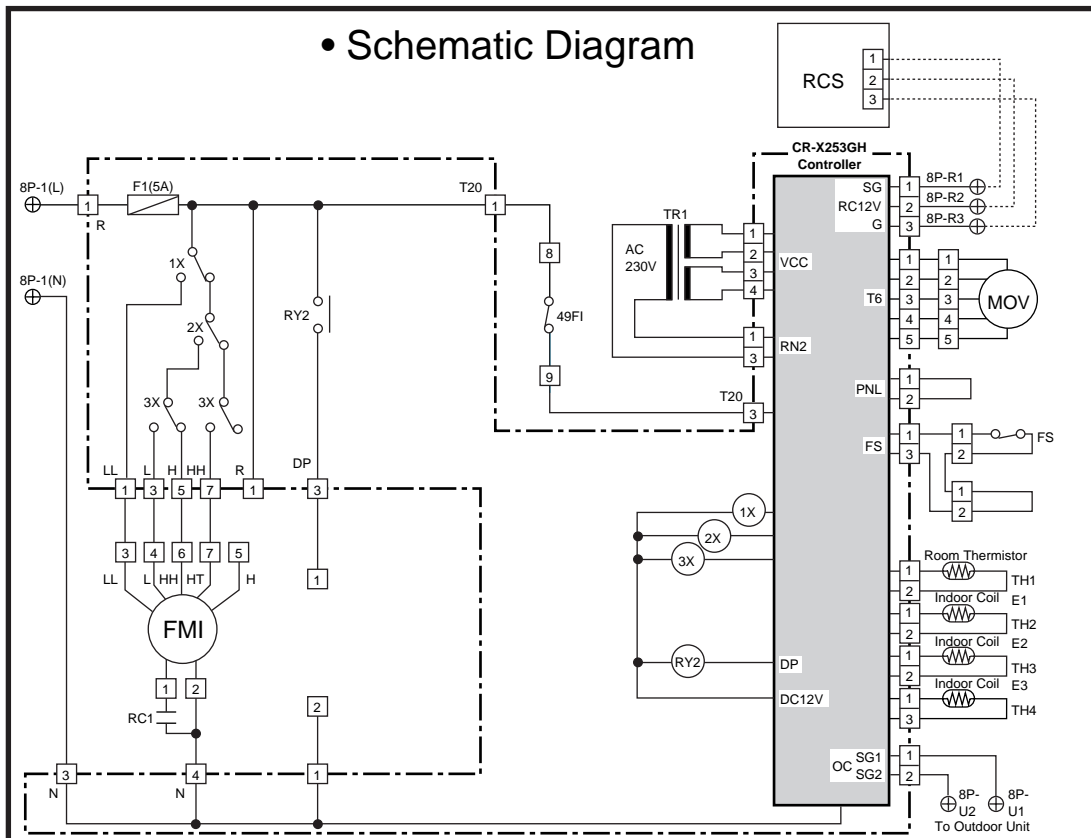

Symbols	Description	Symbols	Description
FMI	Indoor Fan Motor	TH4	Thermistor (Indoor Coil E3)
49FI	Indoor Motor Thermal Protector	CR-X253GH	Indoor Controller
RC1	Running Capacitor	⊕	Terminal Plate
F1	Fuse	□	Connector
TR1	Power Transformer	⊕	Terminal
1X-3X	Auxiliary Relay	FS	Float Switch
RY2	Auxiliary Relay		
MOV	Motor Operated Valve		
RCS	Remote Control Switch		
TH1	Room Thermistor		
TH2	Thermistor (Indoor Coil E1)		
TH3	Thermistor (Indoor Coil E2)		

© 854-2-5268-427-00-1 (D)

3-1 Indoor Unit

① SPW-D483GH56

• Electric Wiring Diagram

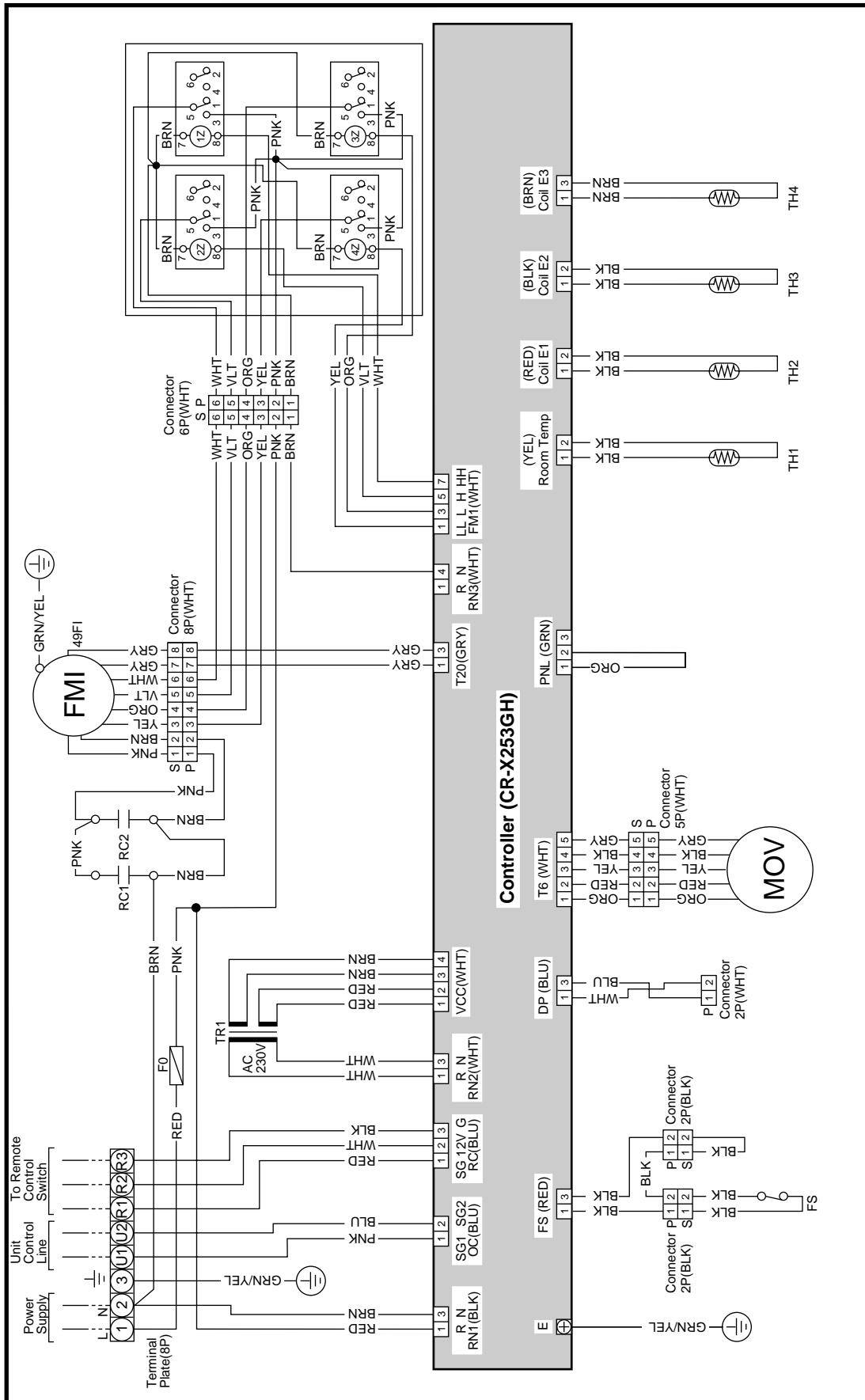

④ 854-2-5268-428-00-1 (D)

3-1 Indoor Unit

① SPW-D483GH56

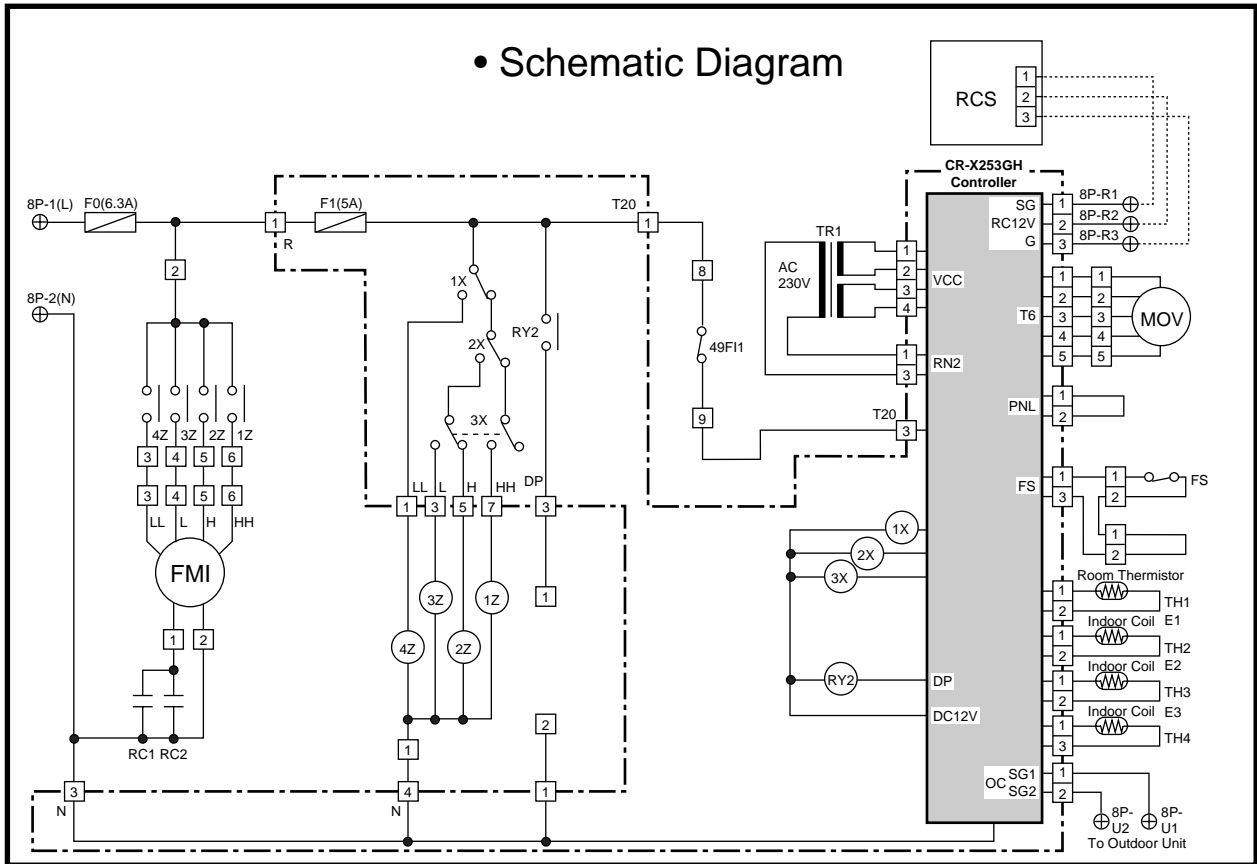

Symbols	Description	Symbols	Description
FMI	Indoor Fan Motor	TH4	Thermistor (Indoor Coil E3)
49FI	Indoor Motor Thermal Protector	CR-X253GH	Indoor Controller
RC1, 2	Running Capacitor	⊕	Terminal Plate
F0, 1	Fuse	□	Connector
TR1	Power Transformer	⊙	Terminal
1X-3X	Auxiliary Relay	FS	Float Switch
RY2	Auxiliary Relay	1Z-4Z	Auxiliary Relay
MOV	Motor Operated Valve		
RCS	Remote Control Switch		
TH1	Room Thermistor		
TH2	Thermistor (Indoor Coil E1)		
TH3	Thermistor (Indoor Coil E2)		

© 854-2-5268-428-00-1 (D)

3-2 Outdoor Unit

① SPW-C253GH5

• Electric Wiring Diagram

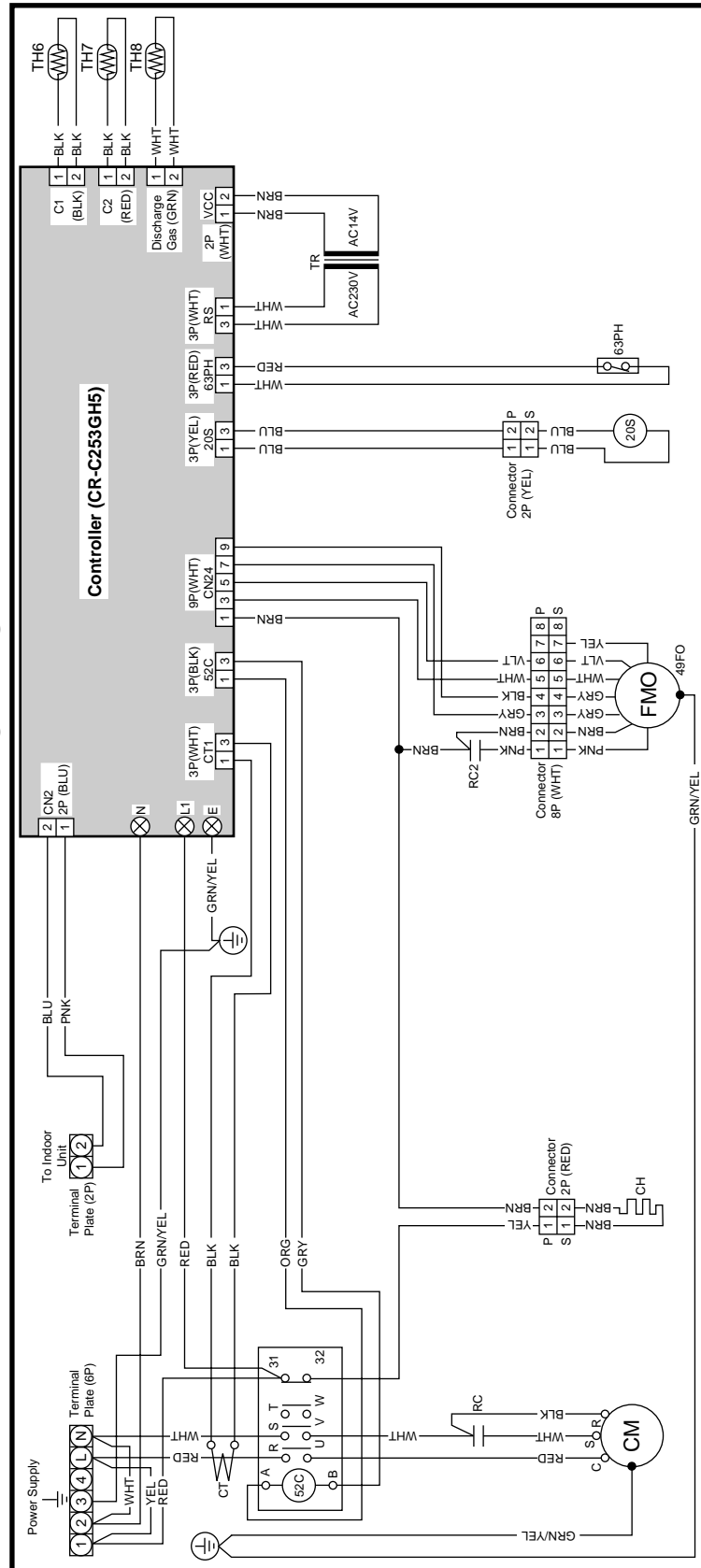

④ 854-2-5268-452-00-2 (C253GH5)

3-2 Outdoor Unit

① SPW-C253GH5

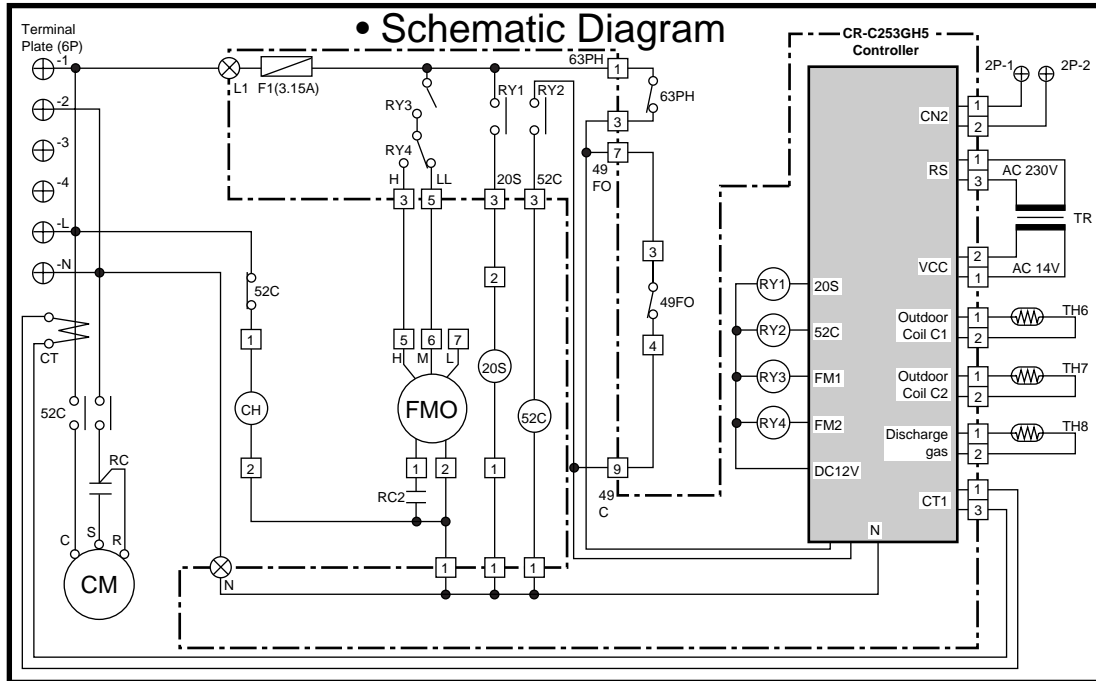

Symbols	Description	Symbols	Description
CM	Compressor Motor	CR-C253GH5	Outdoor Controller
FMO	Outdoor Fan Motor	RY1~4	Auxiliary Relay
52C	Compressor Motor Magnetic Contactor	⊕	Terminal Plate
49FO	Outdoor Fan Motor Thermal Protector	⊗	Terminal
63PH	High Pressure Switch	□	Connector
CT	Current Transmitter		
RC,RC2	Running Capacitor		
TR	Power Transformer		
CH	Crank Case Heater		
20S	Four Way Valve		
F1	Fuse		
TH6	Thermistor (Outdoor Coil C1)		
TH7	Thermistor (Outdoor Coil C2)		
TH8	Thermistor (Discharge Gas)		

© 854-2-5268-452-00-2 (C253GH5)



3-2 Outdoor Unit

② SPW-C253GH8

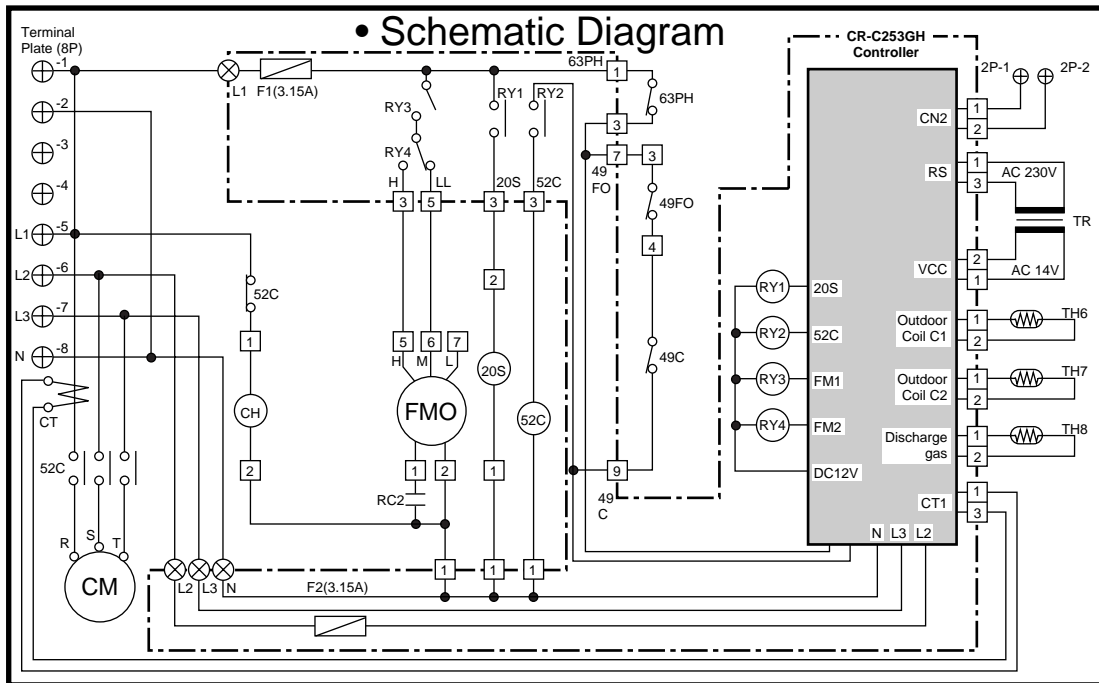

Symbols	Description	Symbols	Description
CM	Compressor Motor	CR-C253GH	Outdoor Controller
FMO	Outdoor Fan Motor	RY1~4	Auxiliary Relay
52C	Compressor Motor Magnetic Contactor	⊕	Terminal Plate
49C	Compressor Motor Thermal Protector	⊗	Terminal
49FO	Outdoor Fan Motor Thermal Protector	□	Connector
63PH	High Pressure Switch		
CT	Current Transmitter		
RC2	Running Capacitor		
TR	Power Transformer		
CH	Crank Case Heater		
20S	Four Way Valve		
F1,2	Fuse		
TH6	Thermistor (Outdoor Coil C1)		
TH7	Thermistor (Outdoor Coil C2)		
TH8	Thermistor (Discharge Gas)		

© 854-2-5268-453-00-0 (C253GH8)



3-2 Outdoor Unit

③ SPW-C363GH8

• Electric Wiring Diagram

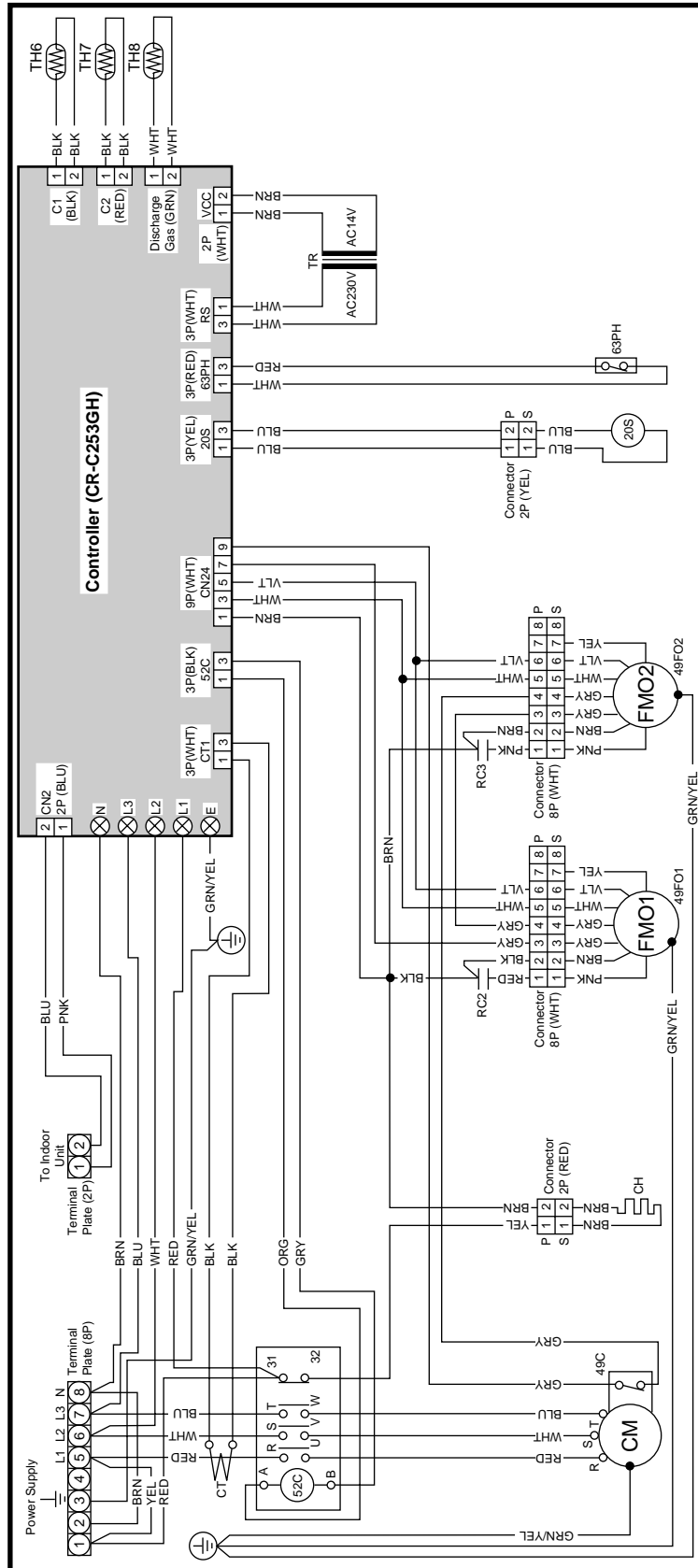

④ 854-2-5268-454-00-1 (C363GH8)

3-2 Outdoor Unit

③ SPW-C363GH8

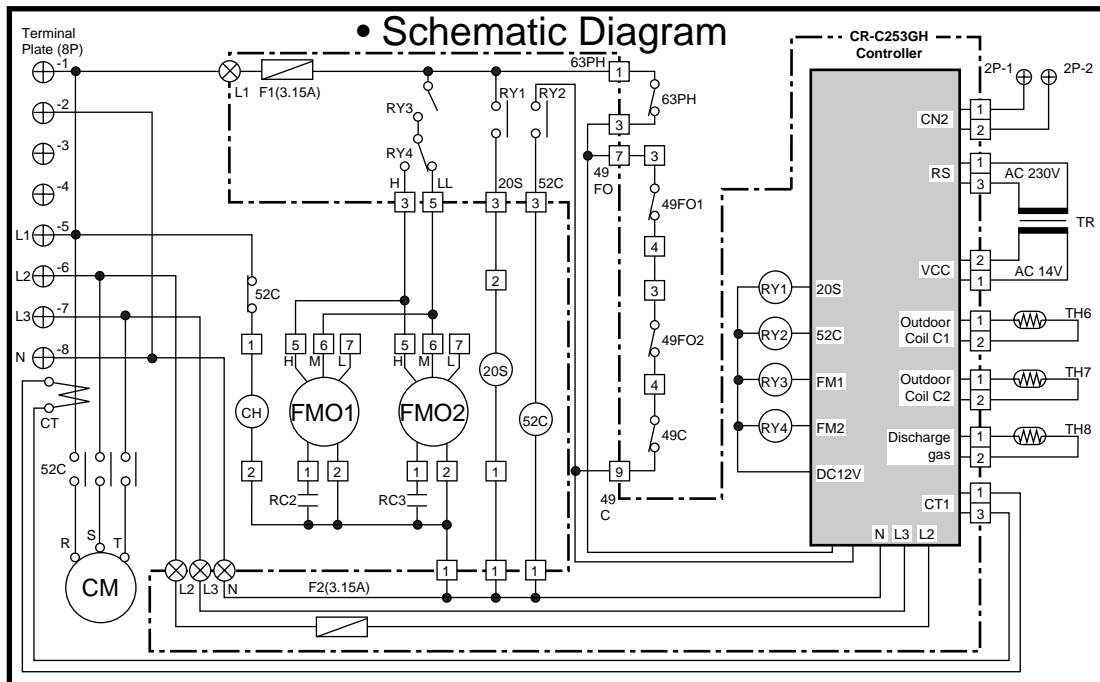

Symbols	Description	Symbols	Description
CM	Compressor Motor	CR-C253GH	Outdoor Controller
FMO1,2	Outdoor Fan Motor	RY1~4	Auxiliary Relay
52C	Compressor Motor Magnetic Contactor	⊕	Terminal Plate
49C	Compressor Motor Thermal Protector	⊗	Terminal
49FO1,2	Outdoor Fan Motor Thermal Protector	□	Connector
63PH	High Pressure Switch		
CT	Current Transmitter		
RC2,3	Running Capacitor		
TR	Power Transformer		
CH	Crank Case Heater		
20S	Four Way Valve		
F1,2	Fuse		
TH6	Thermistor (Outdoor Coil C1)		
TH7	Thermistor (Outdoor Coil C2)		
TH8	Thermistor (Discharge Gas)		

© 854-2-5268-454-00-1 (C363GH8)



3-2 Outdoor Unit

④ SPW-C483GH8

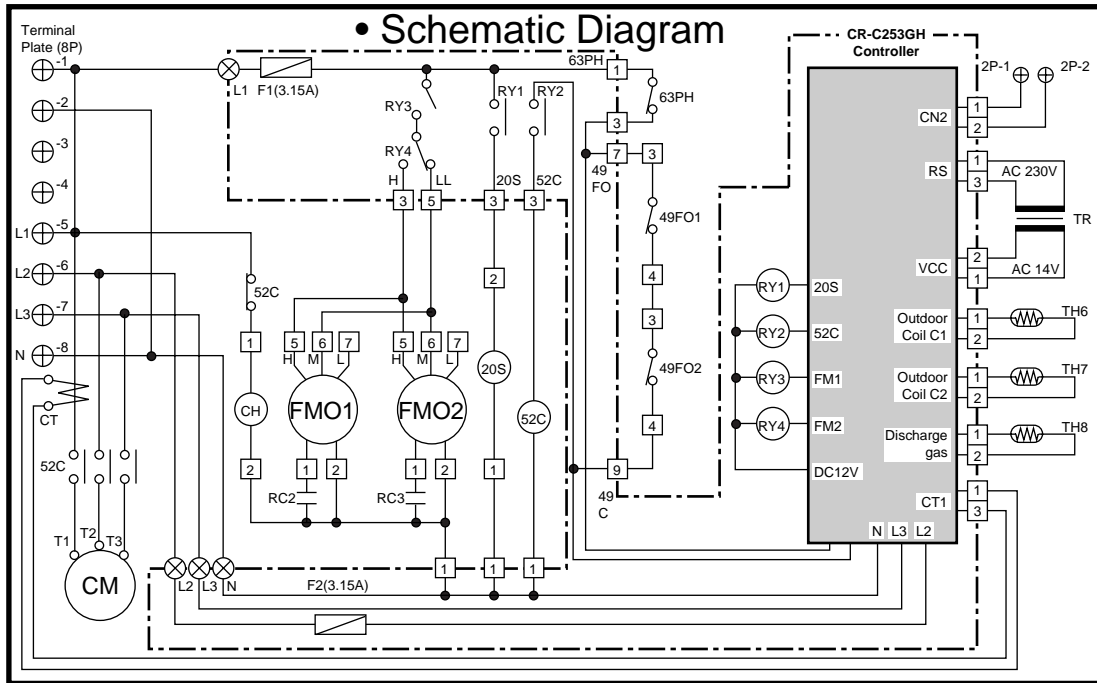

Symbols	Description	Symbols	Description
CM	Compressor Motor	CR-C253GH	Outdoor Controller
FMO1,2	Outdoor Fan Motor	RY1~4	Auxiliary Relay
52C	Compressor Motor Magnetic Contactor	⊕	Terminal Plate
49FO1,2	Outdoor Fan Motor Thermal Protector	⊗	Terminal
63PH	High Pressure Switch	□	Connector
CT	Current Transmitter		
RC2,3	Running Capacitor		
TR	Power Transformer		
CH	Crank Case Heater		
20S	Four Way Valve		
F1,2	Fuse		
TH6	Thermistor (Outdoor Coil C1)		
TH7	Thermistor (Outdoor Coil C2)		
TH8	Thermistor (Discharge Gas)		

© 854-2-5268-457-00-2 (C483GH8)



4. SERVICE PROCEDURES

4-1	Troubleshooting	62
(1)	Check before and after Troubleshooting	63
(2)	General Troubleshooting Flow Chart: Diagnosis and Remedy	65
(3)	Meanings of alarm messages	67
(4)	LED Indication on the Outdoor Unit's P.C.B. Ass'y	69
(5)	Symptoms and parts to inspect	70
(6)	Procedures When a Specific Component Does Not Work	80
(7)	Service Functions of Remote Controller	82
4-2	Checking the Electrical Components	95
(1)	Measurement of Insulation Resistance	95
(2)	Checking the Protective Devices	97
(3)	Checking the Electrical Parts	98
(4)	Sensor and Solenoid Layout Diagram.....	101
(5)	Thermistor Characteristic Curve.....	103
(6)	PCB Setting.....	104
(7)	R.C Address Setting Method.....	105
(8)	Automatic Address Setting Method	106
(9)	Displaying Indoor / Outdoor Unit Combination Numbers	106
(10)	Items to Check Prior to Test Run	107
(11)	Test Run Procedure	108

4-1 Troubleshooting

This section explains:

- What the LED codes mean
- What the remote control unit display screen messages mean
- How to use the flow charts to find and solve problems
- How to use the self-diagnostic tests to find parts that aren't working right

This unit is made to be trouble free, and not need much service. However, with time, moving parts wear out, electronic components break down, and sometimes misuse damages the unit.

The purpose of this section is to help you when the unit is not working properly.

Sometimes your experience will tell you right away where to look for a problem, and when you find it you will know how to fix it at once.

Often, however, all you have is a *symptom* like “poor cooling” or “outside fan doesn't come on.” Now you must find out the cause of the problem, and then how to fix it. This section provides several ways to help you go from the symptom to the cause and then the solution.

The first chart, **General Troubleshooting Flow Chart** is divided into two sections: Poor heating and Poor Cooling. Under each heading you will find the main things that can go wrong and cause either of these problems. Sometimes you can start with this chart and find the problem right away, but often you will come here for more suggestions after you have looked at the error code on the remote control unit display. This chart gives you the “big picture” of problems and solutions.

The other main tool we explain here is the use of the **Alarm Messages**. When a certain part fails or a safety device has shut the unit down, any alpha-numeric codes appears on the display to guide you to the problem.

By understanding the code you can often go right to the problem area and then, with this manual and your knowledge of air conditioning, find the solution.

(1)-1 Check before and after Troubleshooting (SPW-C253GH5)

Many problems may happen because of wiring or power supply problems, so you should check these areas first. Problems here can cause false results in some of the other tests, and so should be corrected first.

①. Check power supply wiring

- Check the power supply wires are correctly connected between terminal No. 1 & 2 on the 3P terminal plates in the indoor unit and the outdoor unit.

②. Check inter-unit wiring

- Check that inter-unit control wiring (DC low voltage) is correctly connected between the indoor unit and outdoor unit.

Power Supply: 50 Hz, single-phase, 220-230-240 V

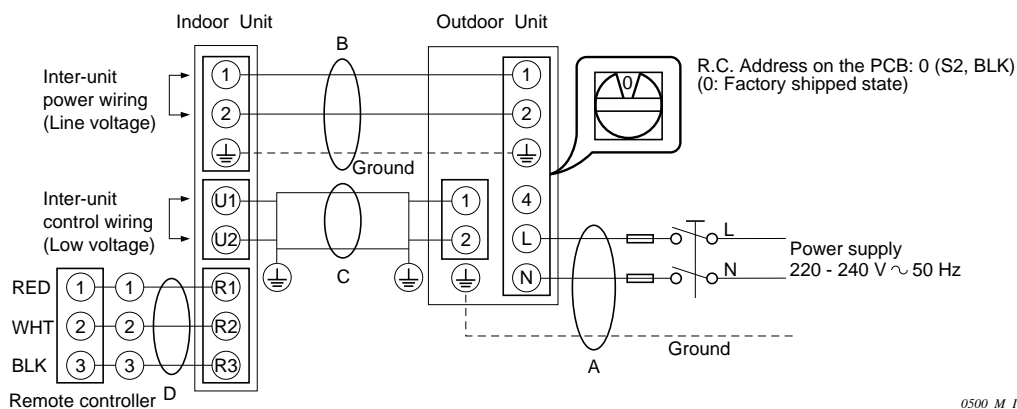

Fig. 28

③. Check power supply

- Check that voltage is within the specified range ($\pm 10\%$ of the rating).
- Check that power is being supplied.



If the following troubleshooting must be done with power being supplied, be careful not to touch any uninsulated live part that can cause ELECTRIC SHOCK.

④. Check the lead wires and connectors in indoor and outdoor units.

- Check that the sheath of lead wires is not damaged.
- Check that the lead wires are firmly connected at the terminal plate.
- Check that the wiring is correct.

(1)-2 Check before and after Troubleshooting (SPW-C253GH8, C363GH8, C483GH8)

Many problems may happen because of wiring or power supply problems, so you should check these areas first. Problems here can cause false results in some of the other tests, and so should be corrected first.

①. Check power supply wiring

- Check that power supply wires are correctly connected to terminal No.5 through No.8 on the 8P terminal plate in the outdoor unit.
- Check the power supply wires are correctly connected between terminal No.1 and 2 on the 3P terminal plate in the indoor unit and terminal No.1 and 2 on the 8P terminal plate in the outdoor unit.

②. Check inter-unit wiring

- Check that inter-unit control wiring (DC low voltage) is correctly connected between the indoor unit and outdoor unit.

Power Supply: 50 Hz, 3-phase, 380-400-415 V

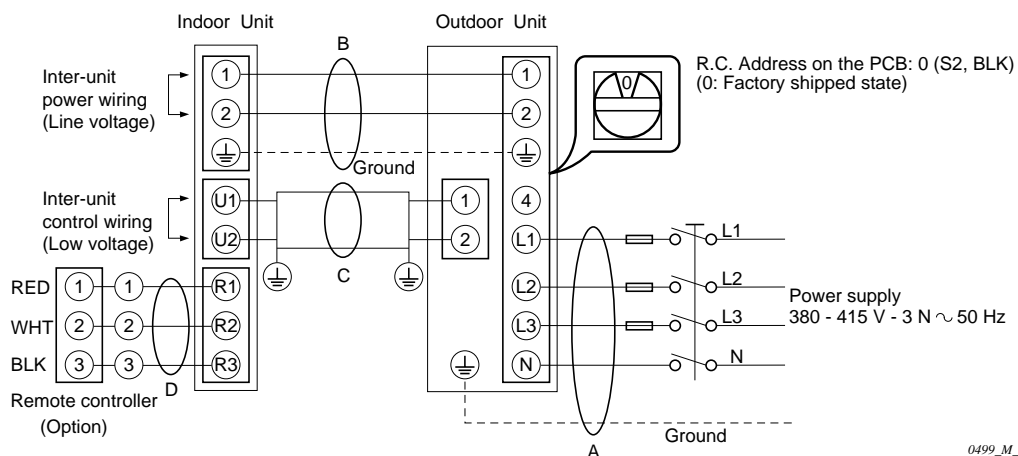

0499_M_I

Fig. 29

③. Check power supply

- Check that voltage is within the specified range ($\pm 10\%$ of the rating).
- Check that power is being supplied.



If the following troubleshooting must be done with power being supplied, be careful not to touch any uninsulated live part that can cause ELECTRIC SHOCK.

④. Check the lead wires and connectors in indoor and outdoor units.

- Check that the sheath of lead wires is not damaged.
- Check that the lead wires are firmly connected at the terminal plate.
- Check that the wiring is correct.

(2) General Troubleshooting Flow Chart: Diagnosis and Remedy

When you have found a major problem, such as refrigerant not flowing in the system or reduced air circulation, come to this section and find the box listing the problem. Connected to the box are the main causes of the problem and their remedies. To find out which malfunction is happening in your case, check the remote controller for an Alarm Message, and follow the steps in section 3).

(A) Cooling

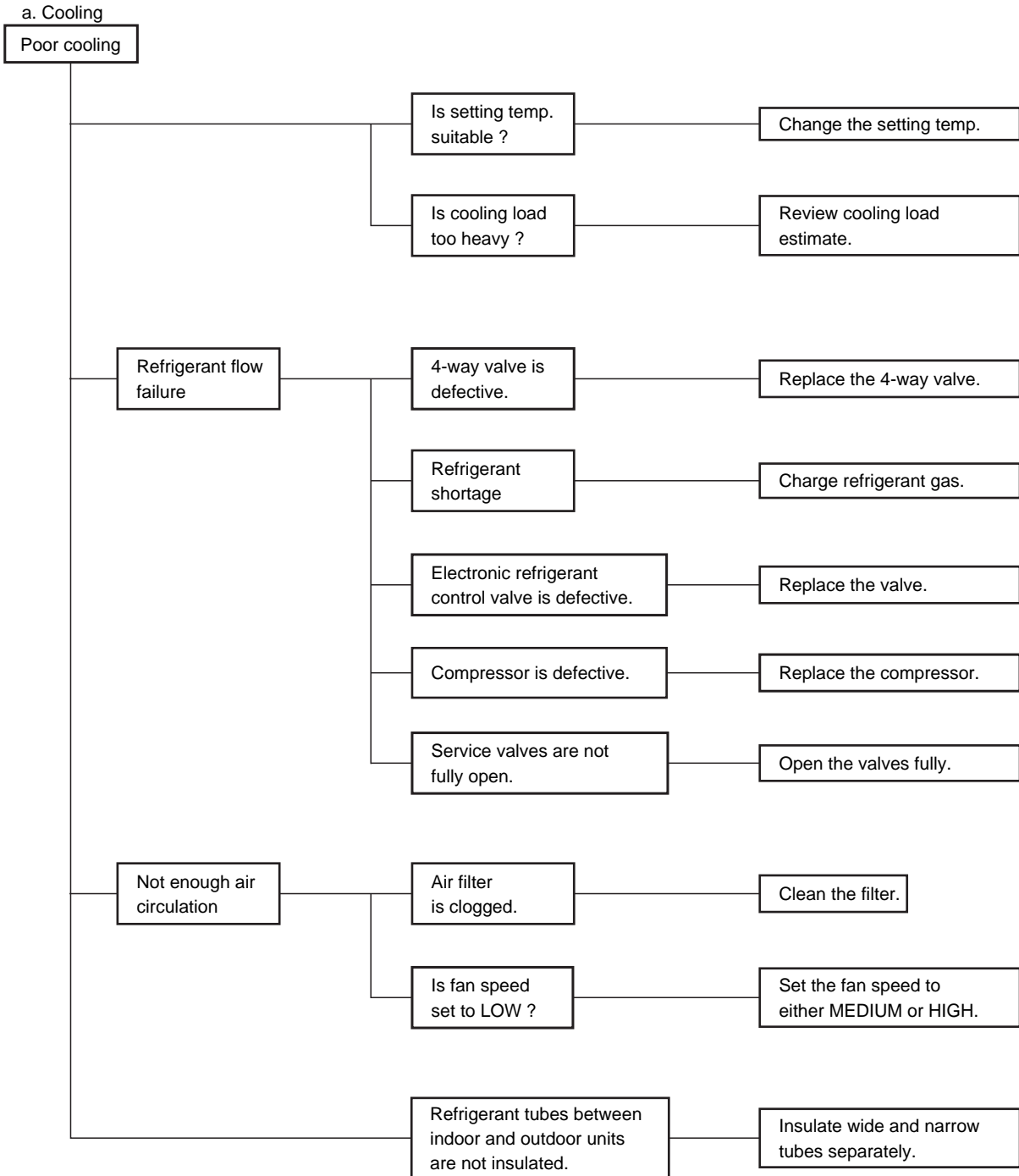

0458_M_I

(B) Heating

b. Heating

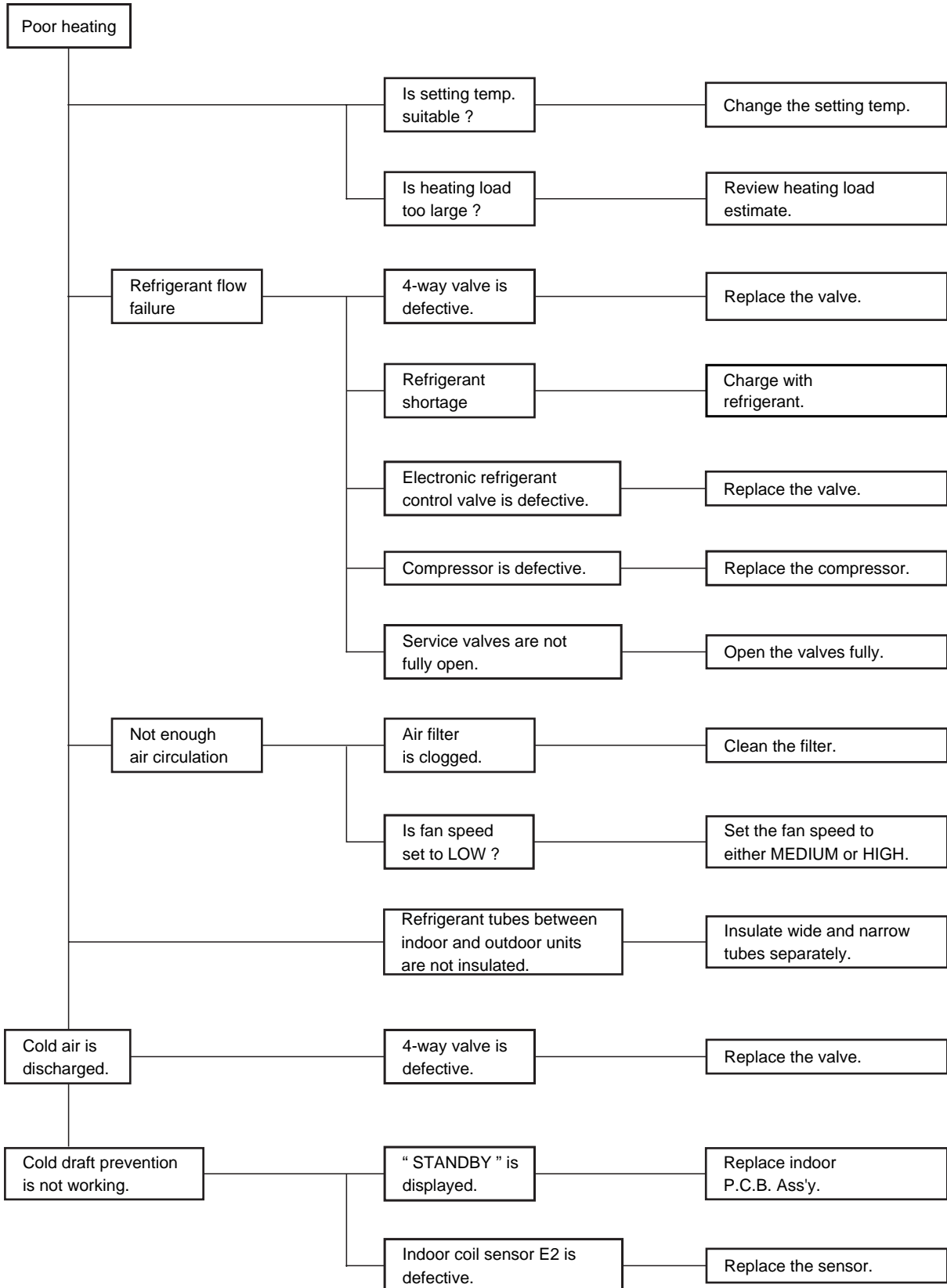

0459_M_I

4

(3) Meanings of alarm messages

If an error occurred in the air conditioner, the error condition is presented by indicating the error code in the wired remote controller display or by the combination of lamp statuses for operation, timer and heat stand-by (OFF status and flashing status).

Possible causes of troubles		Wired remote controller display	Wireless remote controller display	
• Serial communication errors • Mis-setting	Remote controller is detecting unusual signal from indoor unit.	Error receiving of serial communications signal.	E01	
		Error transmitting of serial communications signal.	E02	
	• Indoor unit is detecting unusual signal from the remote controller or group control. (No serial communications signal)		E03	✧: Operation lamp
	Improper setting of indoor unit or remote controller.	Indoor unit address setting is duplicated.	E08	●: Timer lamp
		Remote controller address (RCU.ADR) is duplicated.	E09	●: Heat stand-by lamp
	Indoor unit is detecting unusual signal from signal option.	Error transmitting of serial communications signal	E10	
		Error receiving of serial communications signal.	E11	
	Improper setting of indoor unit or remote controller.	When using flexible combination control, main indoor unit address setting is duplicated. (judged by outdoor unit.)	E14	
	Indoor unit is detecting unusual signal from outdoor unit.	Error receiving of serial communications signal.	E04	Heat stand-by lamp flashes
		Error transmitting of serial communications signal	E05	
	Outdoor unit is detecting unusual signal from indoor unit.	Error receiving of serial communications signal. (Confirmation error of unit numbers included)	E06	●: Operation lamp
		Error transmitting of serial communications signal.	E07	●: Timer lamp
	Auto. address setting is not correct.	No. of judged indoor units or total capacity of indoor units is small.	E15	✧: Heat stand-by lamp
		No. of judged indoor units or total capacity of indoor units is large.	E16	
Indoor unit is detecting unusual signal from another indoor unit.	Error transmitting of serial communications signal	E17		
	Error receiving of serial communications signal.	E18		
• Mis-setting	Improper setting of indoor unit or remote controller.	Indoor unit group address is not correct.	L01	
		Model setting of indoor unit is not matching the outdoor unit.	L02	
		When using group control, main indoor unit address setting is duplicated. (judged by indoor unit.)	L03	
		Outdoor unit address is duplicated.	L04	
		Improper wiring between indoor units. (There is a group connection wiring in case of individual control.)	L07	
		Indoor unit address (or group address) is not set.	L08	
		Capacity code of indoor unit is not set.	L09	
		Improper wiring of group control wiring.	L11	
Indoor unit model setting is improper (capacity)	L13			
Improper wiring connections of ceiling panel.		P09	●: Operation lamp	
• Activation of protective device	Protective device in indoor unit is activated.	Thermal protector in indoor fan motor is activated.	P01	
		Float switch is activated.	P10	
	Protective device in outdoor unit is activated.	• Thermal protector in outdoor fan motor is activated. • PC or AC Compressor thermal protector is activated. • Power supply voltage is unusual. (The voltage is more than 260 V or less than 160 V between L and N phase.)	P02	Operation lamp and heat stand-by lamp flash alternately.
		Discharge gas temperature of PC comp. is unusual.	P03	✧: Operation lamp
		High pressure switch is activated.	P04	●: Timer lamp
		Negative phase or voltage drops.	P05	✧: Heat stand-by lamp
		Other indoor unit is warning.	P31	



Possible causes of troubles			Wired remote controller display	Wireless remote controller display
<ul style="list-style-type: none"> • Thermistor failure 	Indoor thermistor is either open or short.	Indoor coil temp. (E1 = TH2) cannot be detected.	F01	Operation lamp and heat stand-by lamp flash alternately. ☆: Operation lamp ☆: Timer lamp ●: Heat stand-by lamp
		Indoor coil temp. (E2 = TH3) cannot be detected.	F02	
		Indoor room temperature cannot be detected.	F10	
	Outdoor thermistor is either open or short.	Discharge gas temp.A (PC compressor=TH0A) cannot be detected.	F04	
		Outdoor coil liquid temp. (C1 = TH0E) cannot be detected.	F06	
		Outdoor coil gas temp. (C2 = TH0C) cannot be detected.	F07	
		Scroll protection thermostat	F09	
<ul style="list-style-type: none"> • Non volatile memory IC (EEPROM) is abnormal (Indoor control panel) 			F29	
<ul style="list-style-type: none"> • Fault with compressor and its circuit 	Protective device for compressor is activated.	PC compressor motor is overloaded.	H01	●: Operation lamp ☆: Timer lamp ●: Heat stand-by lamp
		PC compressor motor is locked.	H02	
		Compressor current detection circuit is defective.	H03	
		Scroll protection thermostat	H04	
		No detection of scroll protection thermostat	H05	
		Low-pressure switch	H06	
		Power supply voltage between phases is unbalanced.	H17	
		Standard comp. contactor (Mg SW)is chattering.	H18	

☆: flashes

●: OFF

(4) LED Indication on the Outdoor Unit's P.C.B. Ass'y

If something goes wrong with the outdoor unit, **LED** lamps on the **outdoor P.C.B. Ass'y** light up to show the cause of the trouble, in addition to the Alarm message on the remote controller.

LED 2 on P.C. board	LED 1 on P.C. board	Remote controller	Possible cause of trouble
●	●	No message	Normal
●	○	E06, E07, L04	Outdoor unit serial communication signal is abnormal. Outdoor unit address is duplicated.
●	*	No message	Other outdoor units are performing auto address and detecting refrigerant shortage.
○	●	P02	FMo • CM thermal protection is in operation. Power supply voltage is abnormal.
○	○	P04, P05	High voltage SW activates Negative phase protector activates.
○	*	F04~F09	Sensor is abnormal. (Open or short)
*	●	H01, H02	Abnormal compressor current value is detected.
*	○	H04, H05	Scroll thermal protection failure is detected.
* Flash at the same time	*	E15, E16	Auto address failure
* Flash alternately	*	"SETTING" flashes.	Auto address is in operation.

NOTE ●: LED lamps OFF ○: LED lamps ON (lights up) *: LED lamps ON (flashes)

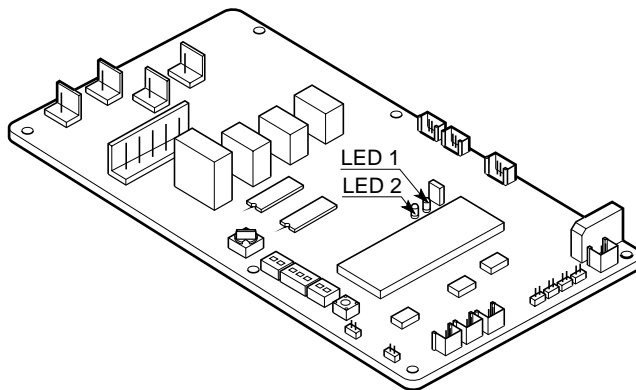

0654_C_1

Fig. 30



*** REFRIGERANT SHORTAGE**

Note particularly that a **shortage of refrigerant** is only shown by the **outdoor P.C.B. Ass'y LEDs** and the Alarm Message does not appear on the Indoor Remote Controller . The compressor keeps running even when the refrigerant is less, so when you find the LED indication on the **outdoor P.C.B. Ass'y**, stop the air conditioner immediately to avoid the compressor damage.

(5) Symptoms and parts to inspect

- Symptom: LCD on the remote controller does not display and remote controller does not operate.

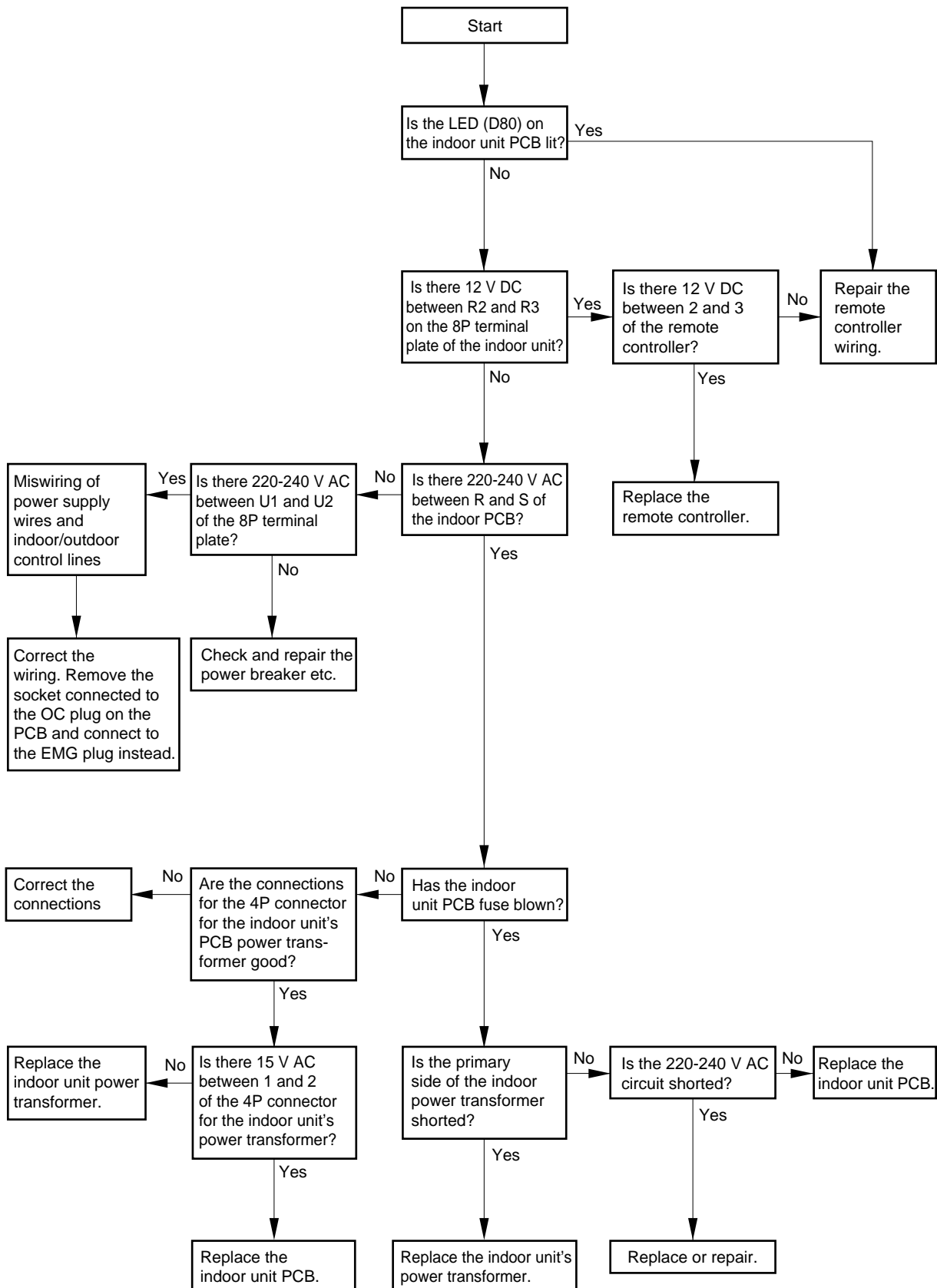

2) Symptom: LCD on the remote controller displays “CHECK E01”. (Unusual communication between remote controller and indoor unit.)

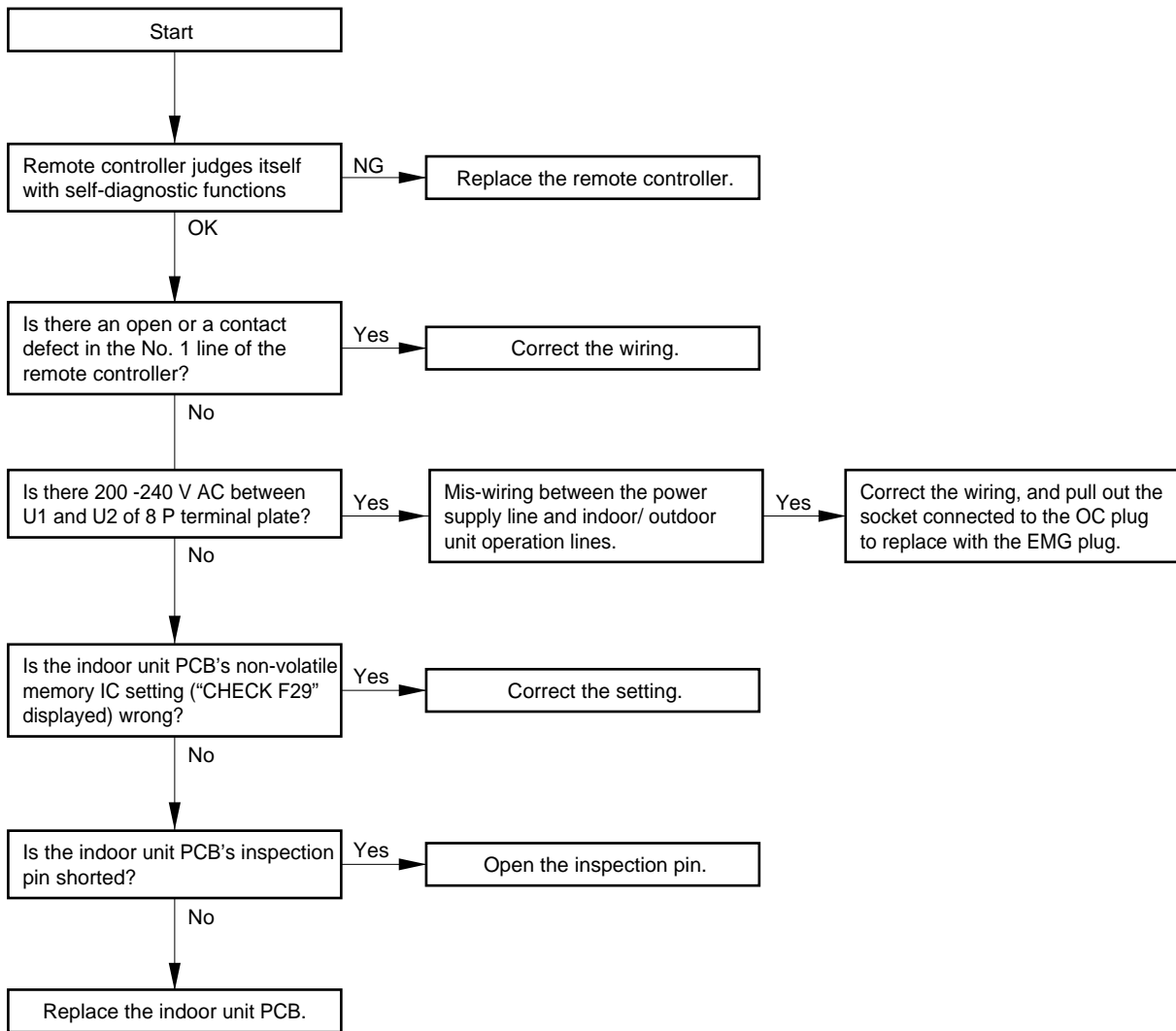

0655_M_1

3) Symptom: LCD on the remote controller displays “CHECK E02”. (Unusual communication between remote controller and indoor unit)

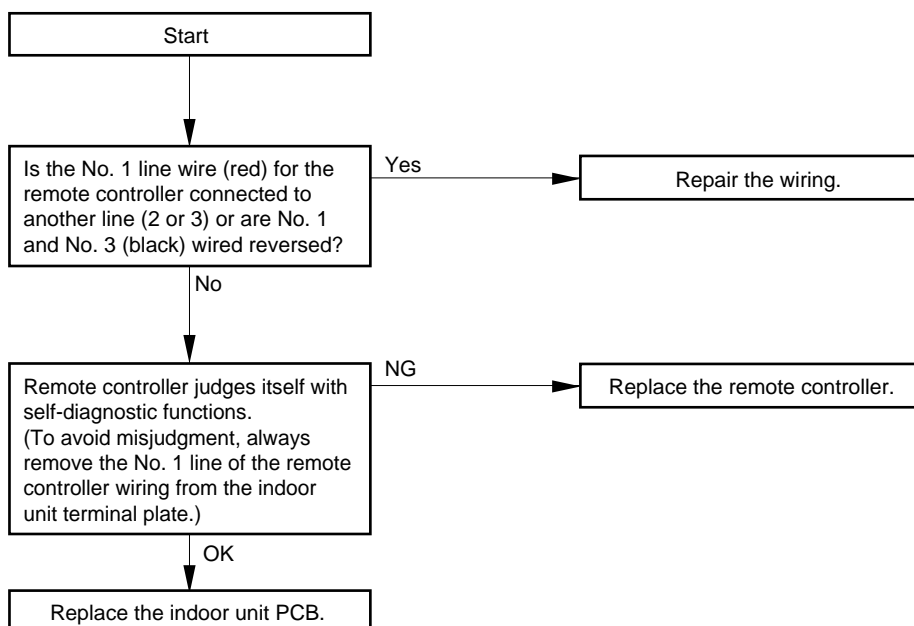

0334_M_1

SM830036

- 4) Symptom: LCD on the remote controller is displaying “CHECK E04”. (Unusual communication between the indoor and outdoor units.)

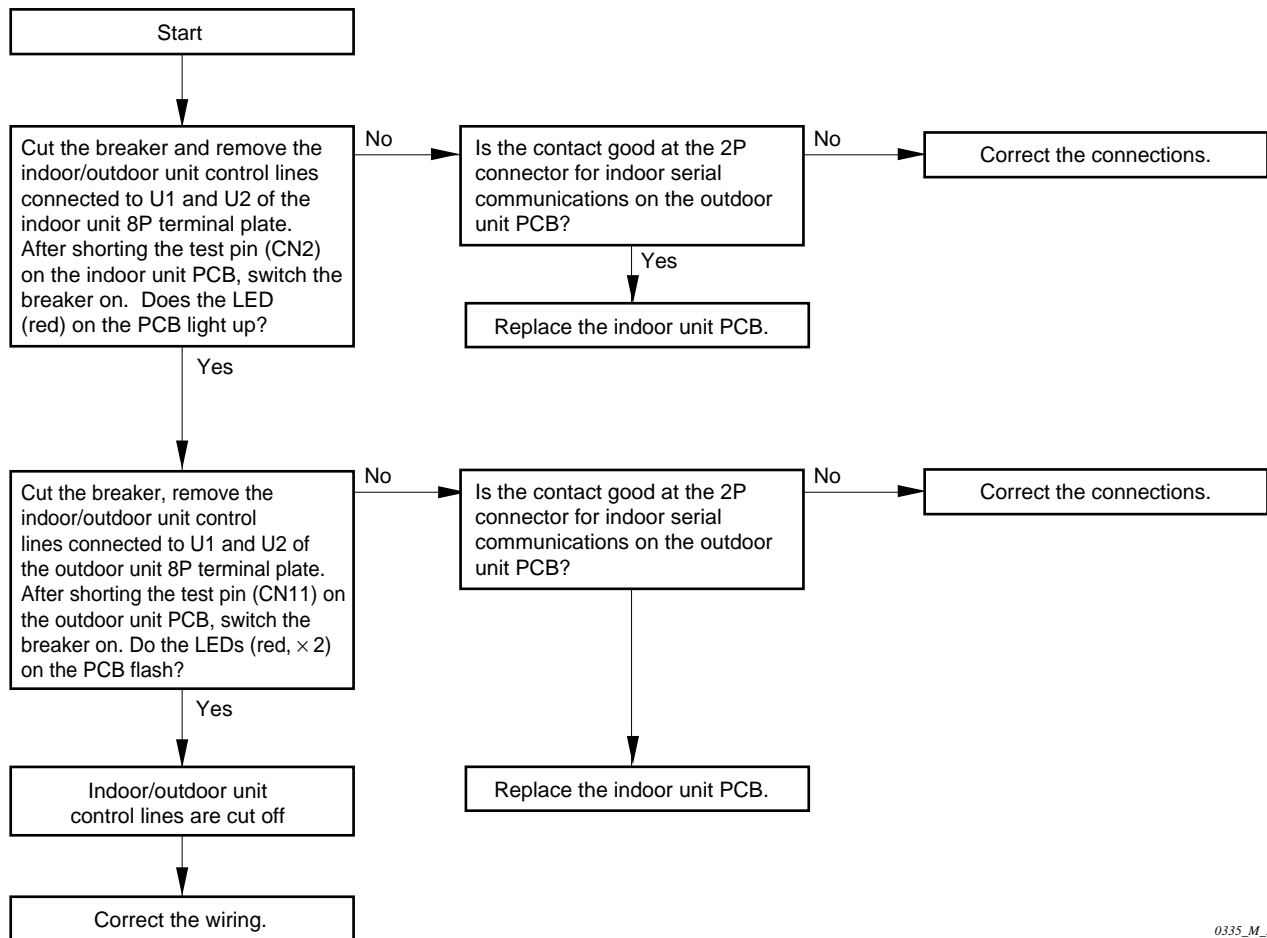

0335_M_I

- 5) Symptom: LCD on the remote controller is displaying “CHECK E05”. (Unusual communication between the indoor and outdoor units)

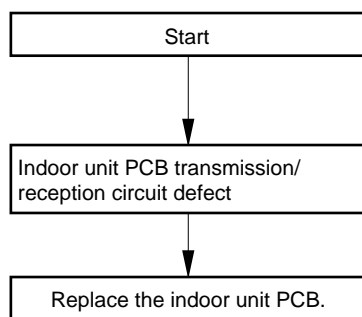

0336_M_I

- 6) Symptom: LCD on the remote controller is displaying “CHECK E06”. (Unusual communication between the indoor and outdoor units)

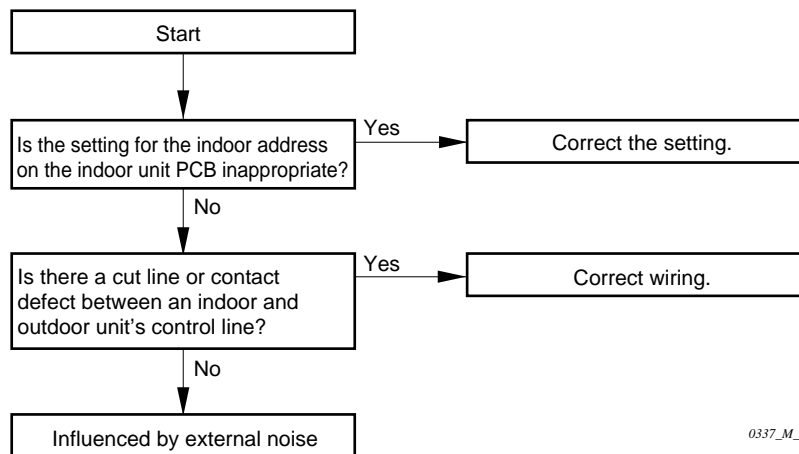

* See the section of INSTALLATION INSTRUCTION concerning with flexible combination system.

- 7) Symptom: LCD on the remote controller is displaying “CHECK E08”. (Duplicate indoor unit address setting)

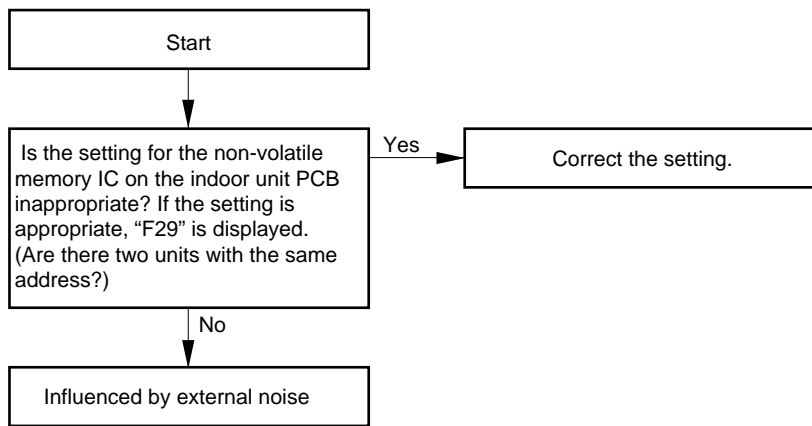

* See the section of INSTALLATION INSTRUCTION concerning with flexible combination system.

- 8) Symptom: LCD on the remote controller is displaying “CHECK E09”. (Duplicate setting of RCU address switch of remote controllers)

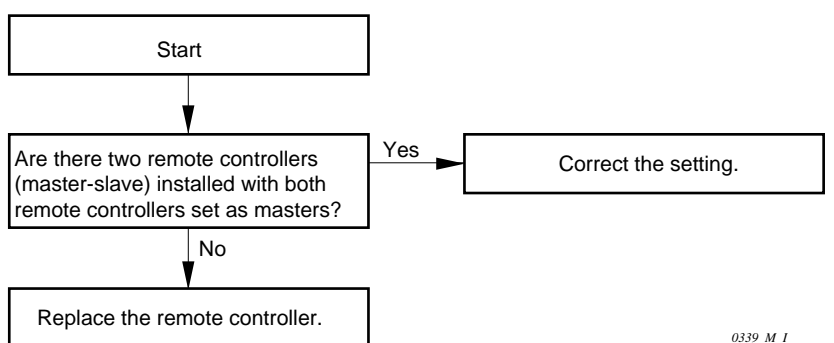

* See the section of INSTALLATION INSTRUCTION concerning with controlling remote controller switches when there are two remote controllers.

- 9) Symptom: LCD on the remote controller displays “CHECK P01”. (Indoor fan protection thermostat operation warning)

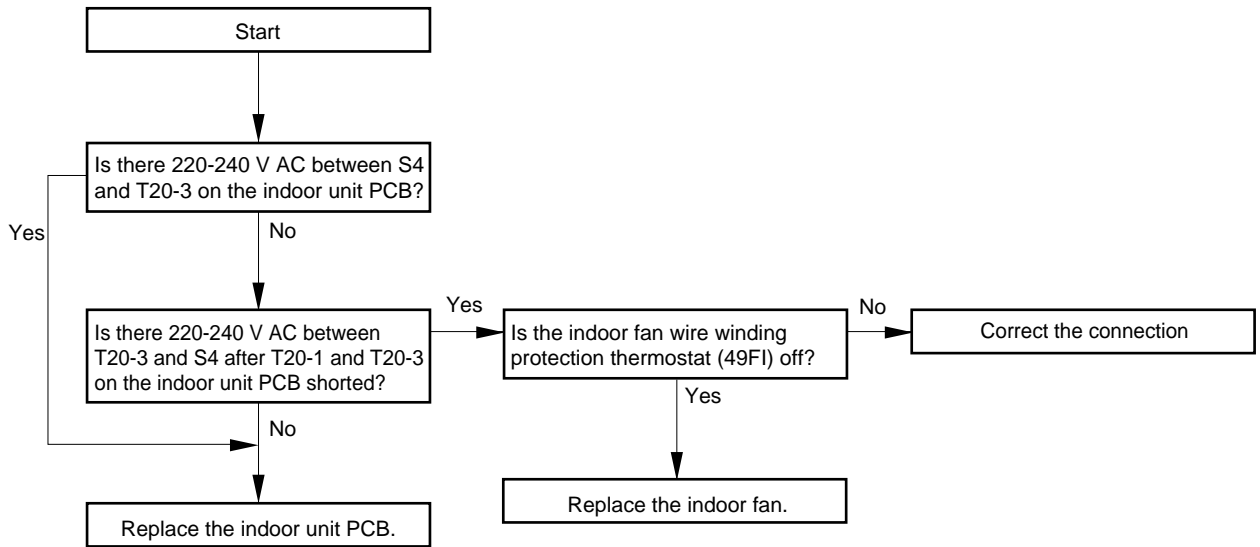

0340_M_I

- 10) Symptom: LCD on the remote controller displays “CHECK P10”. (Indoor float switch operation warning)

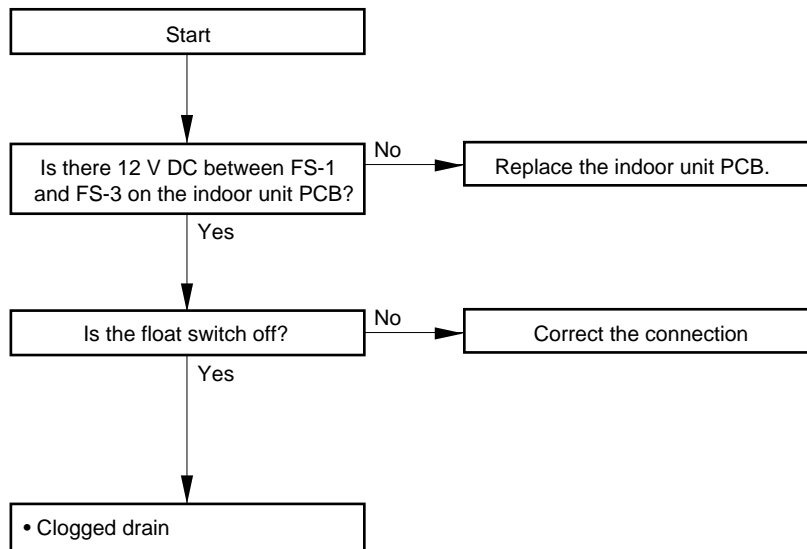

0703_M_I

11) Symptom: LCD on the remote controller displays “CHECK P02”. (Compressor / outdoor fan protection thermostat operation warning / power supply voltage abnormality)

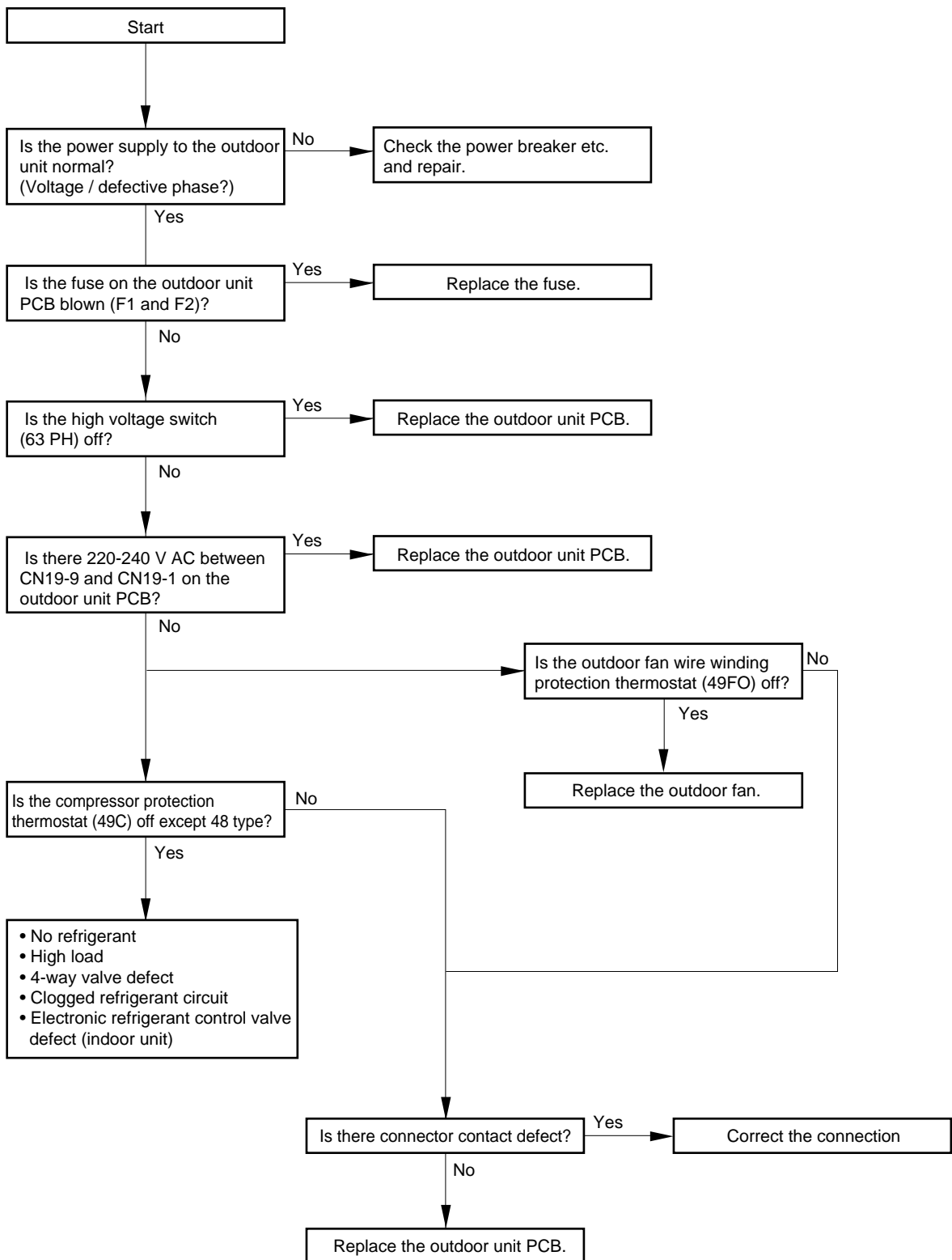

0342_M_1

12) Symptoms: LCD on the remote controller displays “CHECK P03”.
(Alarm for unusual discharge temp. of compressor)

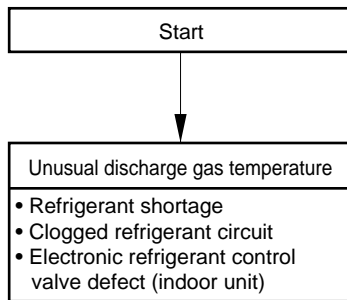

0343_M_I

13) Symptom: LCD on the remote controller displays “CHECK P04”. (High-pressure switch activation warning)

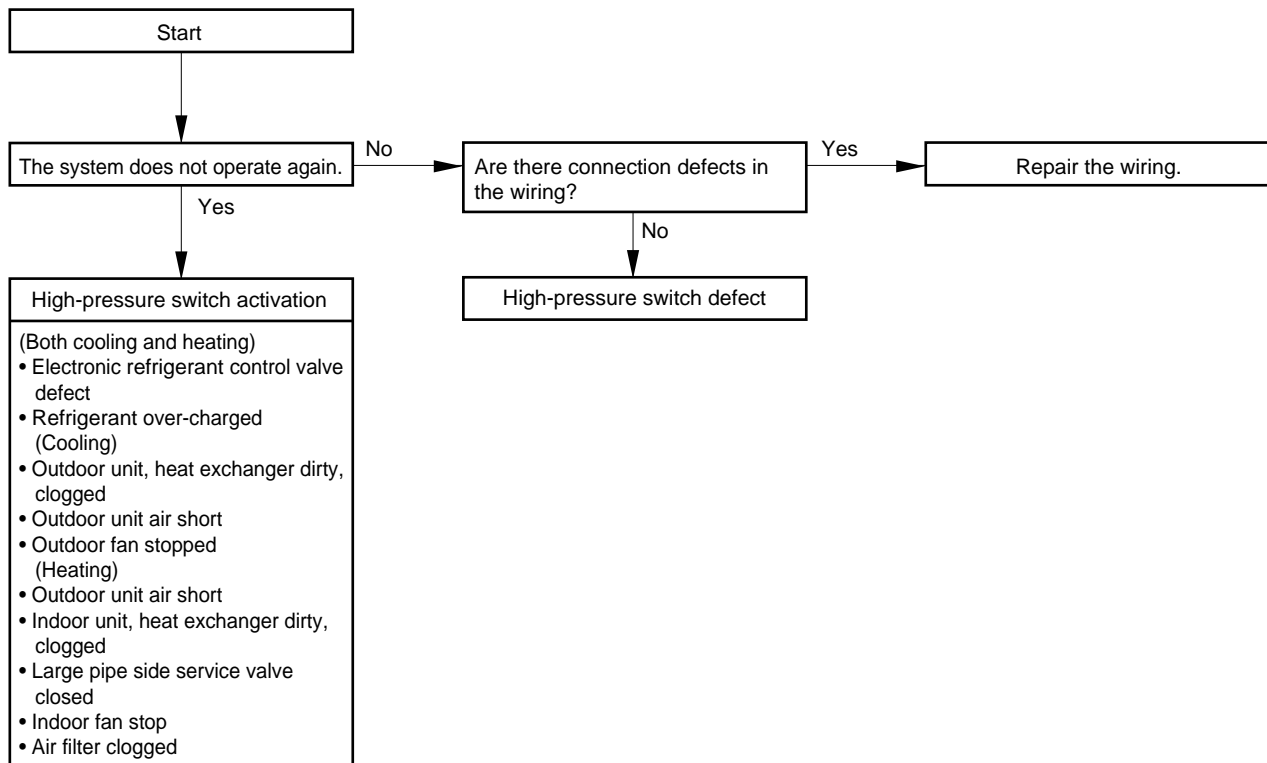

0344_M_I

14) Symptom: LCD on the remote controller displays “CHECK P05”. (Negative phase detection operation warning)

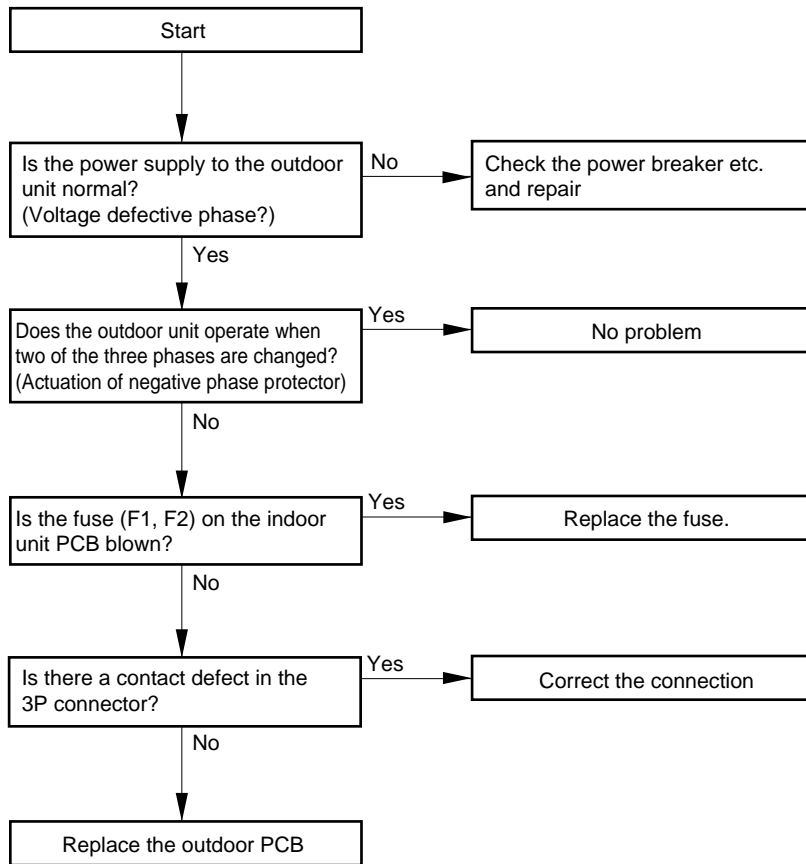

0345_M_I

15) Symptom: LCD on the remote controller displays “CHECK E15”.

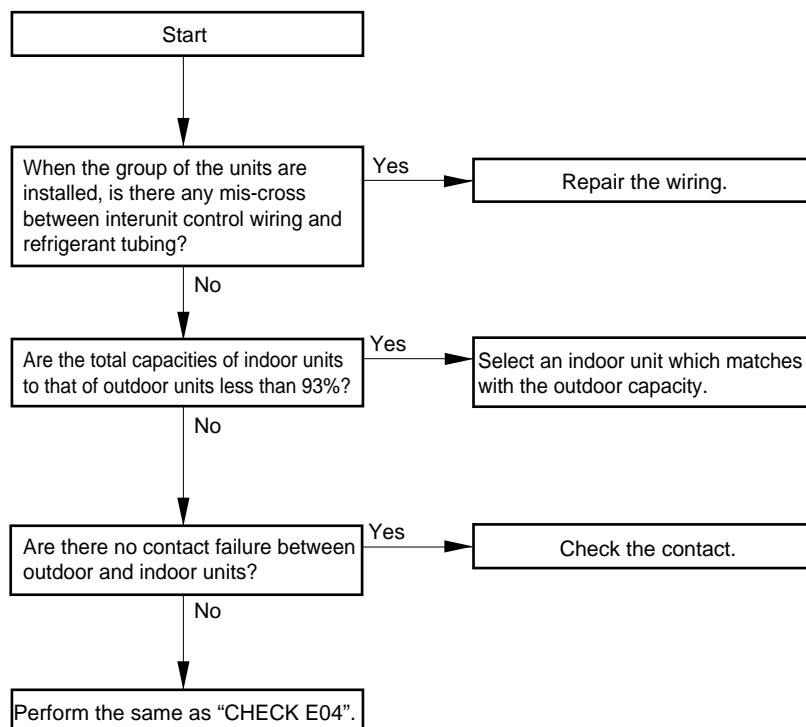

0646_M_S

16) Symptom: LCD on the remote controller displays “CHECK E16”.

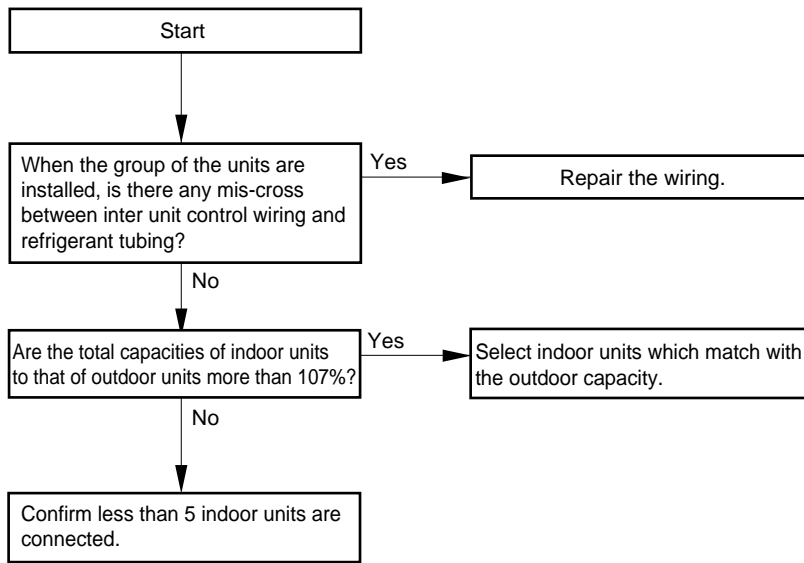

0647_M_S

17) Symptom: LCD on the remote controller displays “CHECK L13”.

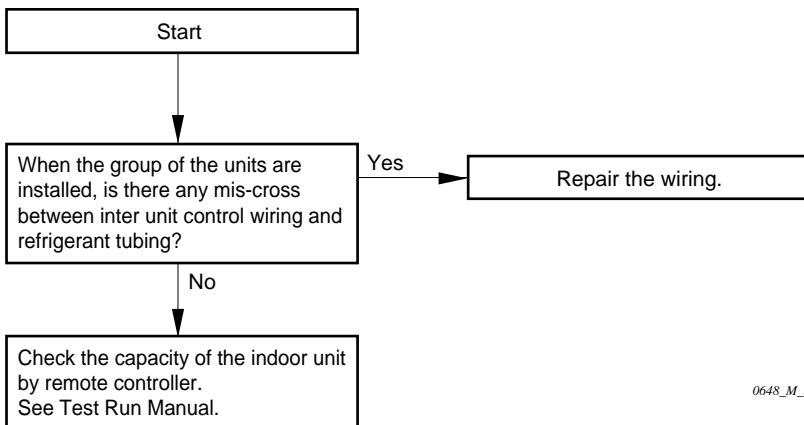

0648_M_S

4

18) “Check P9” is displayed on the remote control unit.

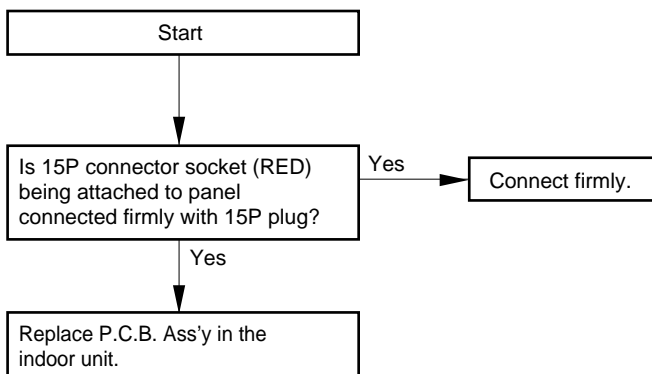

0649_M_S

19) Symptom: LCD on the remote controller displays “CHECK H01, H02, H03”. (PC compressor current detection)

* Please check the related part described in the following chart after confirming the code setting (S4) of the outdoor unit’s capacity on the PCB in the outdoor unit.

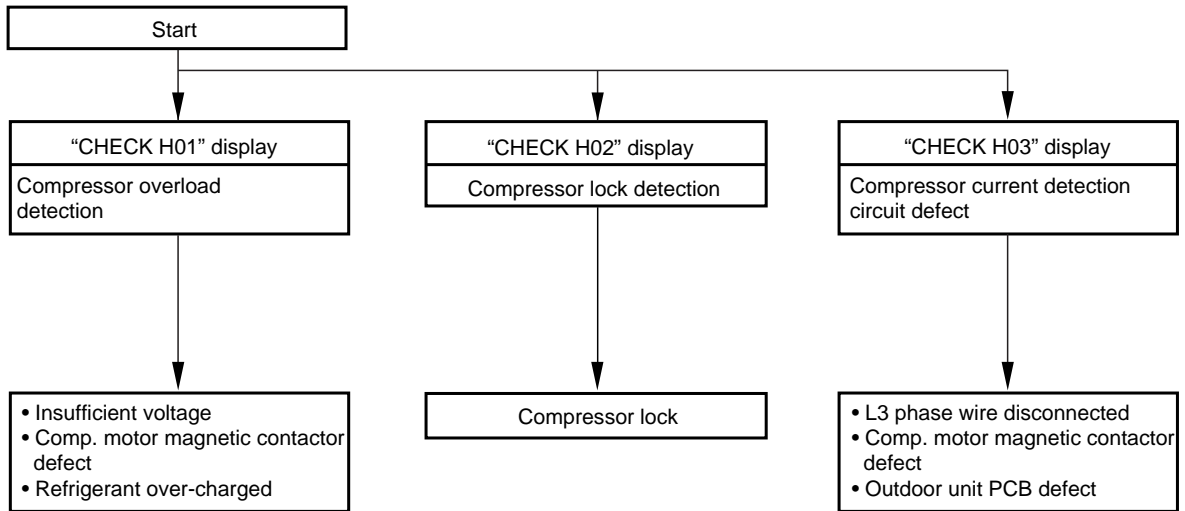

0346_M_I

20) Check the indoor unit (When the alarm of communication failure is not activated)

- If the electronic control valve failure occurred in Flexible Combination system (simultaneous operation system), one indoor unit would not be operated normally, then the other units won't be operated either. Due to this, try to detect the troubled unit and correct it.

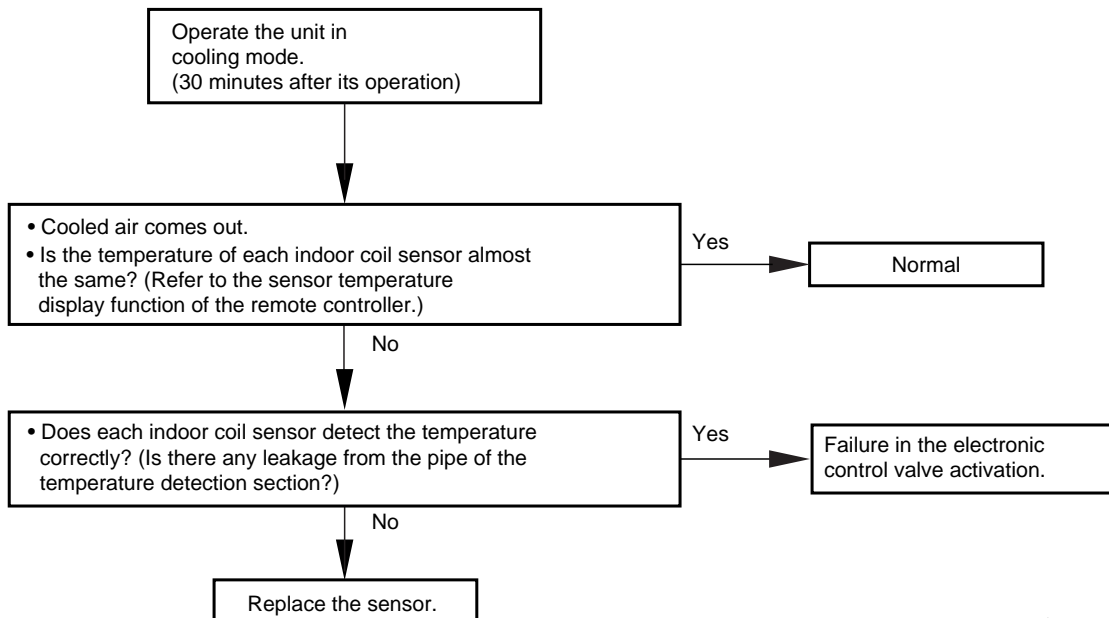

0460_M_I

(6) Procedures When a Specific Component Does Not Work

1) Indoor fan does not operate.

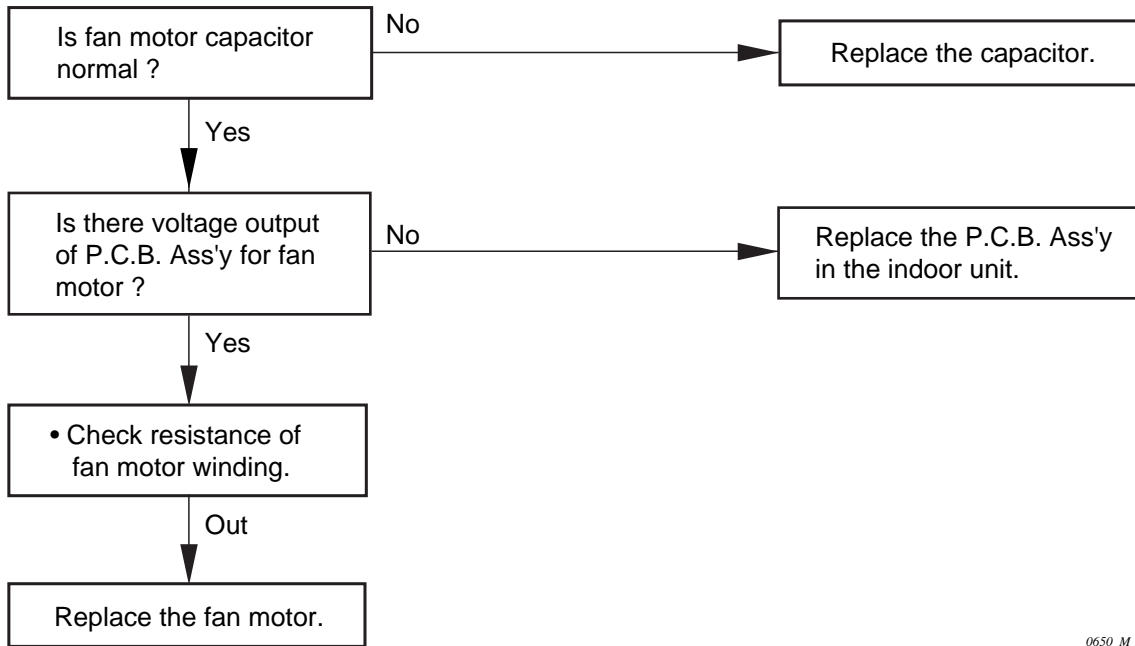

0650_M_S

2) Compressor motor does not operate.

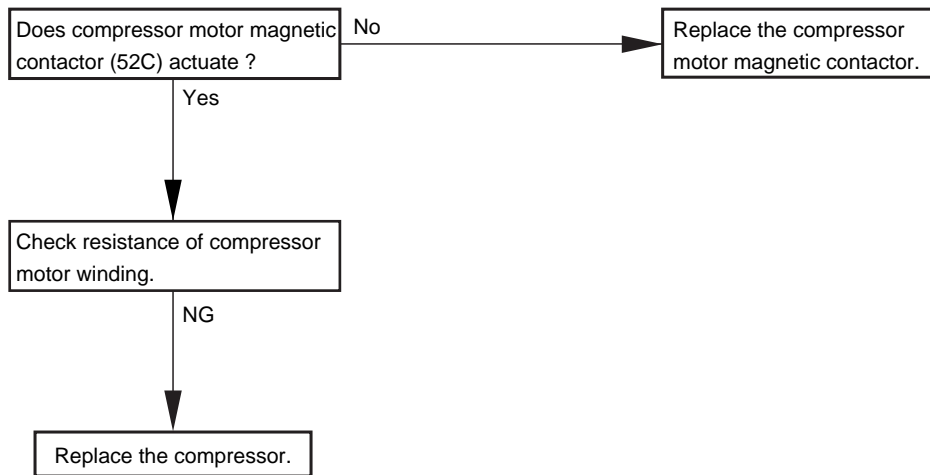

0461_M_1

3) Outdoor fan does not operate.

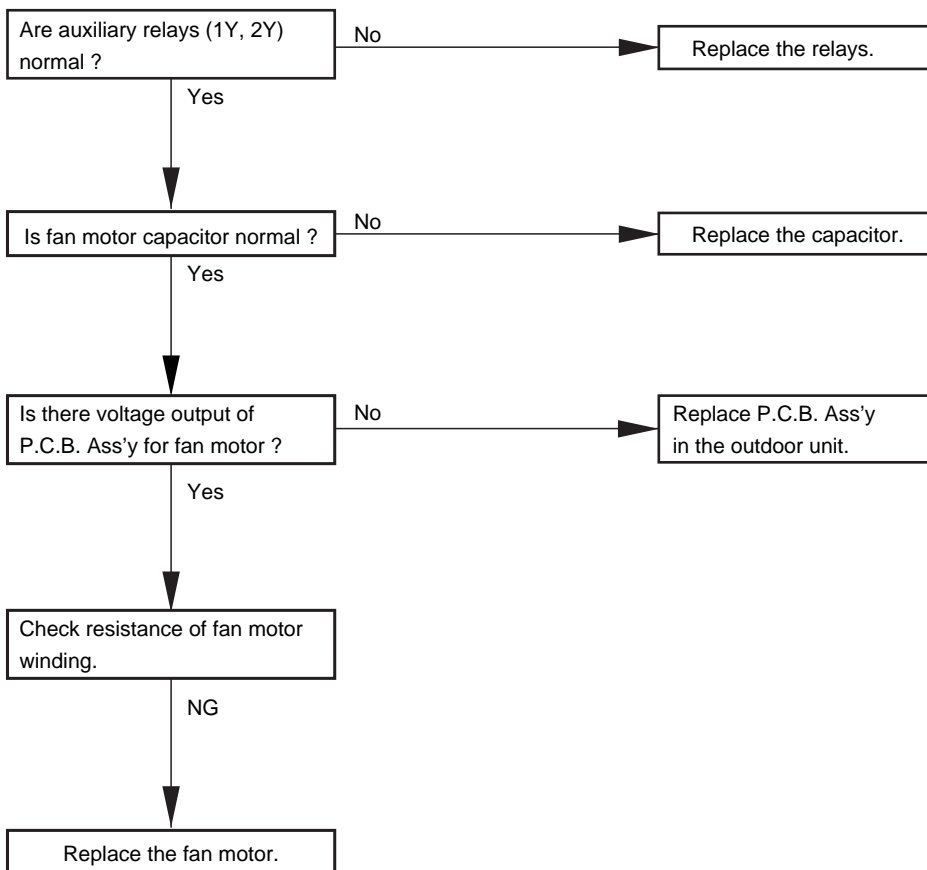

0462_M_1

(7) Service Functions of Remote Controller

From the remote controller you can control both the operation and settings of the unit as well as perform several useful service checks. This section explains how to use the remote controller on the following items from (A) to (J).

- (A) Set service check switches.
- (B) Use the test run procedure.
- (C) Check the sensor temperature readings.
- (D) Find out about past service problems.
- (E) Check the remote controller itself for correct operation.
- (F) Excute the auto. address operation.
- (G) Confirm and change the indoor unit address.
- (H) Change the shift temperature in heating mode
- (I) Set the indoor unit address.

(A) Set service check switches

The service check switch (RCU.CK) is located on the back of the remote controller's P.C.B. Ass'y as follows :

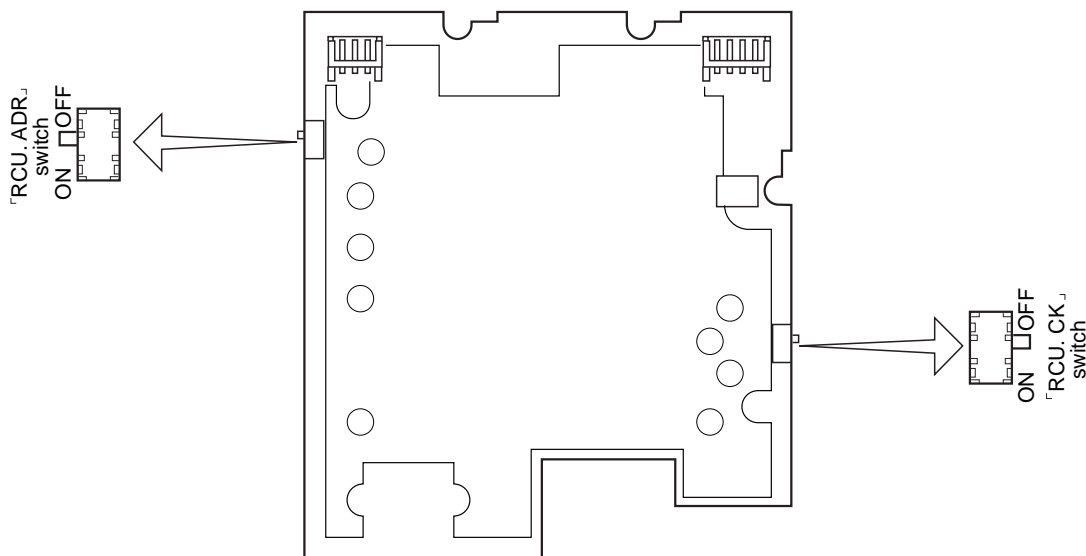

The followings are the correct switch settings for ordinary use of the unit. Only change the settings temporarily for making service checks. When you finish the settings, **be sure to return them to the standard settings** shown here.

- RCU.CK** switch - Refer to section (E) “ **Checking the remote controller for correct operation**”
(Remote Control Unit, Check)
- RCU.ADR** switch - Keep the switch **OFF** all the time except in case of sub remote controller
(Remote Control Unit, Address)

(B) Use the test run procedure

- ❑ The purpose of the test run function is to let you control the operation of the unit directly without turning the unit on or off by thermostat. As indicated in the following procedure, be sure to stop test run operation when you finish the procedure, or the air conditioner may be damaged.
- ❑ To protect the air conditioner from overloading, the outdoor unit will not start running for 3 minutes after power is applied or the unit is turned OFF.

- a Press the **TEST / CHK** button at the bottom right on the remote controller.
- b Press the **ON / OFF** operation button to start the test run.
- c Press the **MODE** button to select either **COOLING** or **HEATING** mode.
- d When the test run starts, "TEST" shows on the remote controller's display.
- e During the test run, the air conditioner runs continuously and the thermostat does not control the system.
- f After the test run, be sure to press the **TEST / CHK** button once again to finish this mode and make sure "TEST" is not shown on the display.

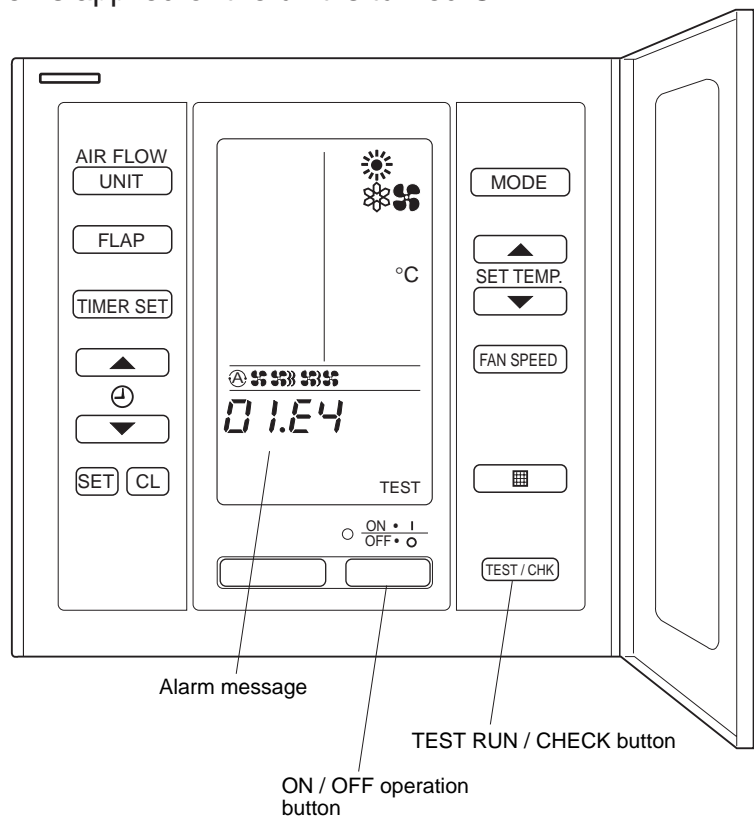

0355_M_I



The TEST RUN button is used only for servicing the air conditioner. Do not press this button in normal operation, or the system may be damaged.

(C) Check the sensor temperature readings

The air conditioner has thermo sensors which are used to control the unit.

- ❑ Each sensor has an address which is made up of the indoor unit address, and the sensor address. The indoor unit address is used only when several units are hooked up to one remote controller (group control). If there is only one unit, made up of one indoor and one outdoor unit, then only the sensor address should be put in, as shown in the procedure below.

Follow this procedure to display the temperature of each sensor:

- a) On the remote controller, press both **TEST / CHK** and **CL** buttons at the same time for more than 4 seconds.

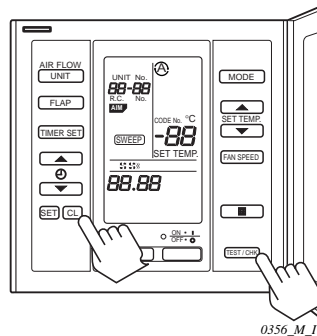

- b) The UNIT No., the address and temperature of the sensors instead of its usual information will flash on the display.
- ❑ Following example shows the UNIT No. (Indoor unit address) is fixed at **01-01**.
 - ❑ In case of group control, select the UNIT NO. (Indoor unit address) which you want to check with **UNIT** button.
 - ❑ Each time you press the **▲**, **▼** (SET TEMP.) button you can select a different sensor, and the display shows the sensor address and temperature as shown below.

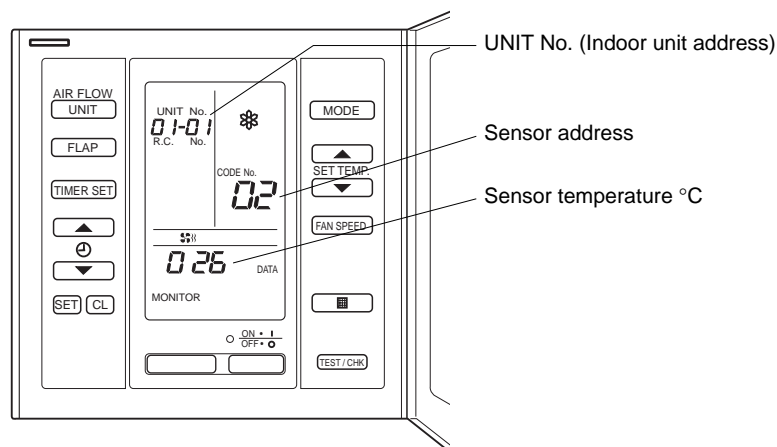

NOTE

Do not press **TIMER SET** button during the procedure.

Refer to the table below for the relationship between the sensor address and the location of the sensor.

Relationship between the sensor address and the location of sensor

Sensor Address (CODE No.)		Location of Sensor (Themistor)	
Indoor Unit	01	—	
	02	TH1	Indoor air suction Temp.
	03	TH2	Indoor coil Temp. (E1)
	04	TH3	Indoor coil Temp. (E2)
	05	—	
Outdoor Unit	06	—	
	07	—	
	08	—	
	09	—	
	0A	TH0A	Discharge gas Temp. A
	0B	TH0B	Scroll protection thermostat
	0C	—	
	0D	TH0D	Outdoor coil liquid Temp. (C2)
	0E	TH0E	Outdoor coil liquid Temp. (C1)
	0F	—	
	10	—	
	11	—	
	12	—	
	13	—	
14	—		

NOTE

In case there are no sensor equipped with the unit, “- -” is shown on the display.

© Resetting the remote controller display to previous mode.

- To reset the display, press **TEST / CHK** button, then the remote controller will return to previous mode.

(D) Find out about past service problems

The remote controller can memorize the **max. 4 most recent alarm messages**, so you can see problems the unit has had, if any. Knowing what has already occurred and been fixed helps you to know what to check at present.

- This function is usable even if the unit is not working.
- To display the past error codes, follow the procedure below.

Procedure:

- a) On the remote controller, press both **TEST / CHK** and **SET** buttons at the same time for more than 4 seconds.
- b) Once in this mode, display changes from the normal display to service check display as shown in the table below:

NORMAL DISPLAY	Display Change (→)	SERVICE CHECK DISPLAY
Set temp.	→	Code No.
UNIT No.	→	UNIT No. (Indoor unit address)
Hours, Minutes	→	Alarm Message

This picture shows the service check display.

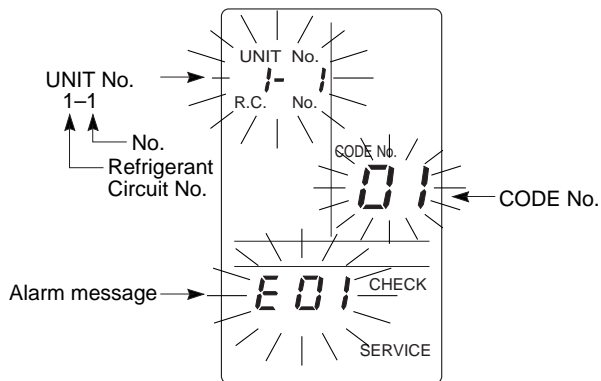

0358_M_I

©. A maximum of 4 alarm messages can be accessed by pressing either **SET TEMP** button ▲ or ▼ as follows.

MODE

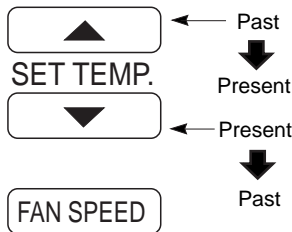

NOTE Pressing **CL** (Clear) button will clear all the service history.

- ▲ ... accessed in order of "Past → Present".
- ▼ ... accessed in order of "Present → Past".

0359_M_I

For example, if the last four alarm messages were, in order of occurrence from oldest to most recent, **P01**, **P02**, **P04**, and most recently **E01**, then the display will be shown as below when you press ▼ button four times. The 5th time you press ▼ button you can repeat the display, then the first message will be shown again.

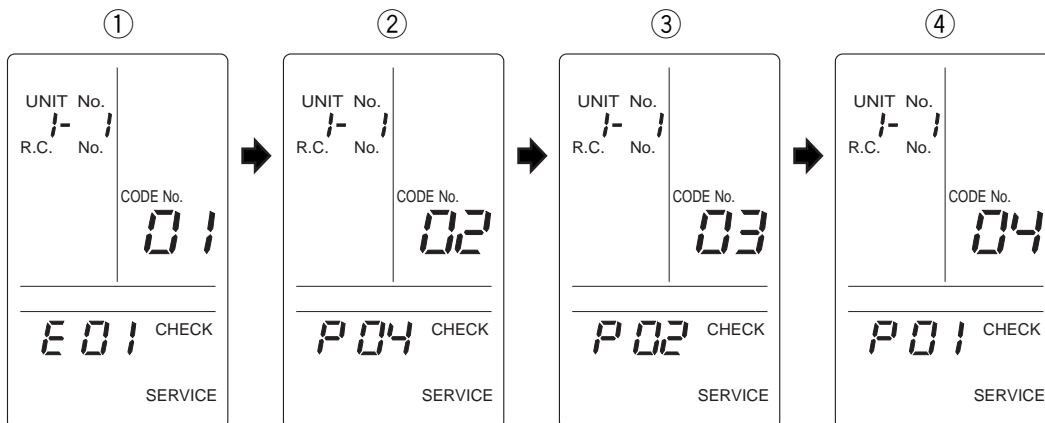

If there are no alarm messages, the display shows:

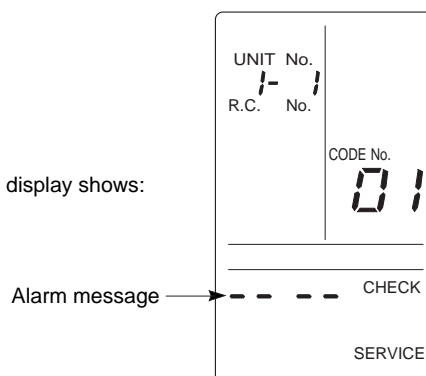

0360_M_I

Important

Never press **CL** (clear) button unless you want to erase the accessed data in memory. Follow the procedure below only when erasing is necessary.

- To erase accessed data, press the **CL** button.
- When erasing is finished,“----” mark appears on the controller’s display.



After checking the alarm messages, be sure to press the **TEST / CHK** button.

(E) Check the remote controller itself for correct operation

The remote controller has a **self-diagnostic** function to check if it works properly. Use this procedure to find out if the remote controller itself is in trouble.

- a) Turn ON the **RCU.CK** switch on the back of the **P.C.B.** Ass’y in the remote controller. See section **(A)** for exact location.
- b) The appearance of the display will tell you whether or not the remote controller is working correctly or not.
 - Normal condition** – All displays appear for 10 seconds, then disappear.
 - Unusual condition** – All displays flash ON and OFF for 10 seconds, then disappear.



After checking the panel, be sure to set the **RCU.CK** switch to this original **OFF** position.

(F) Execute the auto. address operation

- ❑ Auto. address operation is executed by pressing the A. ADD (S1) button of outdoor unit's PCB usually.
For your convenience it can be executed by remote controller also.

- Ⓐ Press the **TEST / CHK** and **▲ (⊕)** buttons at the same time for more than 4 seconds.
- Ⓑ Set CODE No. A1 with **▲ , ▼ (SET TEMP)** button.

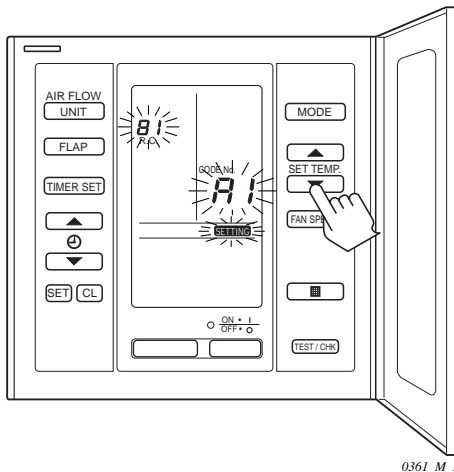

In this mode, the auto. address operation is executed at each R.C. (Refrigerant Circuit) line one by one.

- Ⓒ Select R.C. No. which you want to execute the auto. address operation with **UNIT** button.
- Ⓓ Press the **SET** button. The auto. address operation will start. CODE No. changes from flashing to ON state.
- Ⓔ If an error occurs during operation, the alarm message will be displayed. Check and remove the cause. If you want to stop the operation, press the **CL** button then the unit stands in waiting mode (Press the **SET** button again.)
- Ⓕ If the automatic address operation finishes, the display will disappear.
- Ⓖ Execute the operation of the other R.C. line in the same way by following the above steps Ⓒ to Ⓓ .
- Ⓗ Complete the automatic address operation by pressing the **TEST / CHK** button.

(G) Confirm and change the indoor unit address

- ❑ The purpose of the above function is to let you confirm the indoor unit address after the auto. address operation, and change the indoor unit address if it is needed.

- (a) Press the **TEST / CHK** and **▼ (⊖)** buttons at the same time for more than 4 seconds.

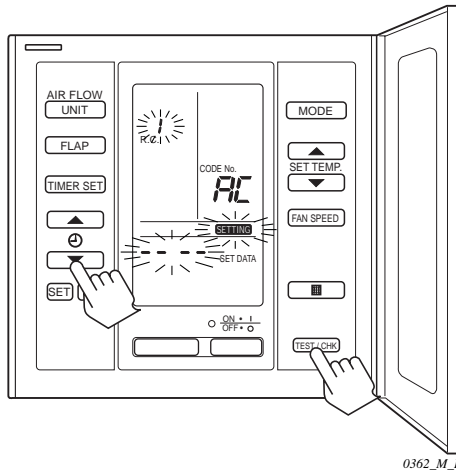

- (b) Select the R.C. No. which you want to change with the **UNIT** (up) or **FLAP** (down) buttons.
- (c) Press the **SET** button (to confirm the R.C. No.).
The smallest registered indoor No. and the selected R.C. No. will be displayed.

Ex:

R.C. No. 3 is selected.
Indoor No. 2 is the smallest indoor No. of the R.C. No. 3.

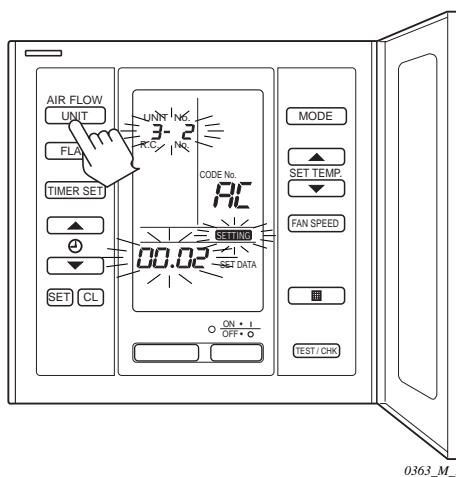

- (d) Select the indoor No. which you want to change with **UNIT** button. Once in this mode, **the fan motor of selected indoor unit will turn on and let you confirm the indoor unit address.**

- Ⓔ Set the required new indoor unit's No. by pressing the ▲ , ▼ (⊕) button.

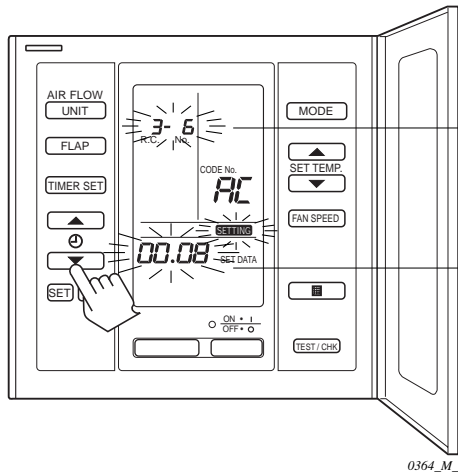

Ex: UNIT No. 3-6: currently registered indoor unit address

Required new indoor No.8: SET DATA

* In this case, UNIT No. 3 – 6 (current)

≠
3 – 8 (NEW : after pressing the
TEST / CHK button)

- Ⓕ Press the SET button.
UNIT No, SET DATA (0008) and **SETTING** changes from flashing to ON state.
- Ⓖ If you made a mistake, press the **CL** button.
- Ⓗ Finally, press the **TEST / CHK** button.
- Ⓘ If you want to change the indoor unit address of the other R.C. No., follow the step Ⓐ to Ⓖ in the same way.

(H) Change the shift temperature in heating mode

- ❑ If the indoor unit is installed at high location (ex. ceiling level), the thermostat tends to turn off at heating mode because of the hot air temperature around ceiling level. In order to solve the problem, the shift temp. (valid while heating only) is set when shipped from factory.
- ❑ If the shift temp. is not enough (ex. the indoor unit is installed at position higher than 3 m), the shift temp. can be set with remote controller from +1 to +10 deg. manually as follows:

- ① Press the **TEST / CHK** button for more than 4 seconds.

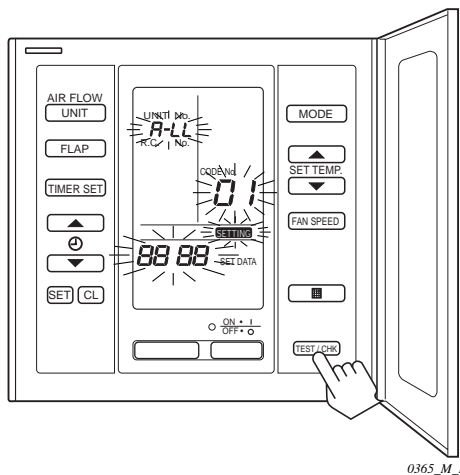

0365_M_I

- ② In case of group control, if you want to change all units in group control collectively, proceed next step remaining ALL displayed. If you want to change a unit individually, select the indoor unit address (UNIT No.) with **UNIT** button.
- ③ Select the CODE No. 06 with ▲ , ▼ (**SET TEMP**) button.
- ④ Choose the shift temp with ▲ , ▼ (⊕) button.

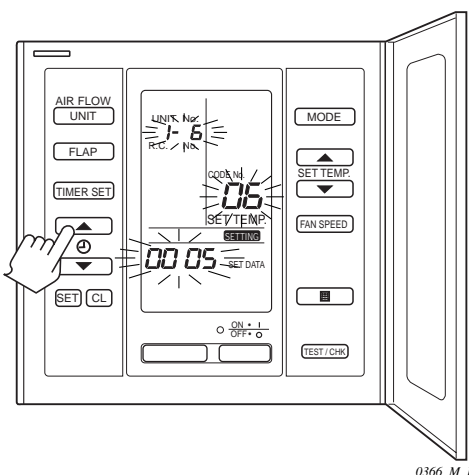

0366_M_I

EX:
 UNIT No. 1-6
 CODE No. 06
 Shift temp. +5 deg

- ⑤ Press the SET button. CODE No. 06, SET DATA and **SETTING** change from flashing to ON state.
- ⑥ If you made a mistake, press the **CL** button.
- ⑦ Finally, press the **TEST / CHK** button.

(1) Set the indoor unit address

- ❑ This function is usable if the auto. address operation is not available. Indoor unit address can be set one by one by remote controller in such case.

NOTE

- 1) In case of group control, branch wiring for group control should be removed temporarily.
- 2) In case of remote controllerless system, remote controller should be connected with the indoor unit temporarily.

- a) Short the two terminals of DISP PIN on indoor unit PCB.
(DISP PIN : Refer to P. VI-2)
- b) Press the **TEST / CHK** , **SET** and **CL** buttons at the same time for more than 4 seconds.

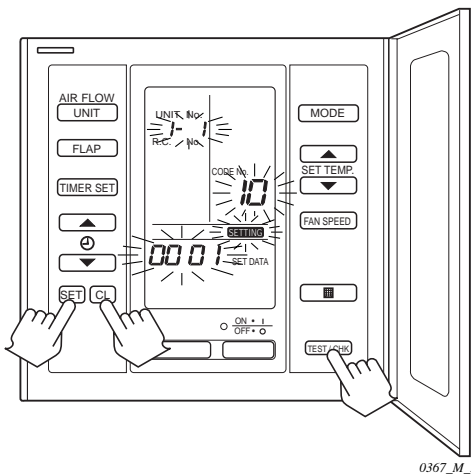

- c) Set the CODE No. 12 to set the No. of R. C. with the ▲ , ▼ (**SET TEMP**) button.

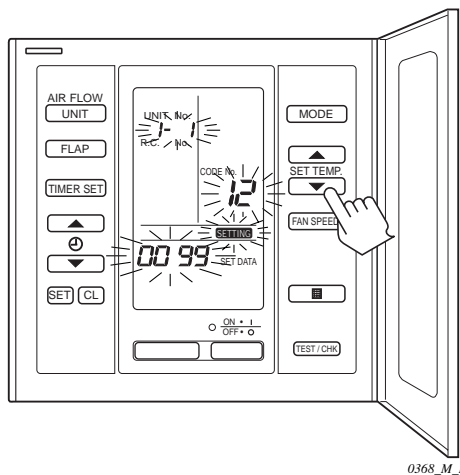

- ④ Set the No. of R. C. which you want to set with ▲ , ▼ (⊕) button.

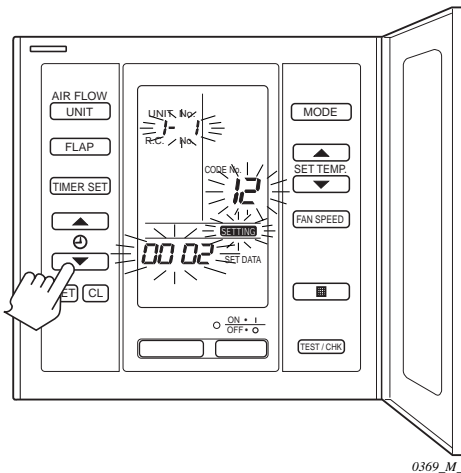

Ex. No. of R. C. will be set 2.

- ⑤ Press the **SET** button.
UNIT No., CODE No. 12, **SETTING** and SET DATA (0002) change from flashing to ON state.
- ⑥ Select the CODE No. 13 to set the indoor unit No. with the ▲ , ▼ (**SET TEMP**) button.
- ⑦ Set the indoor unit No. which you want to set with the ▲ , ▼ (⊕) button.

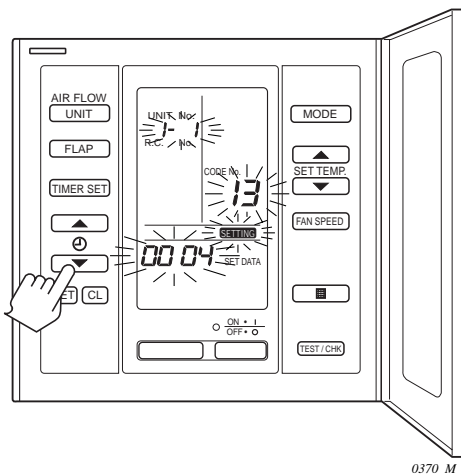

Ex. Indoor unit No. 4 will be set.
In this example, indoor unit address (UNIT No.) will be set 2-4.

- ⑧ Press the **SET** button.
UNIT No., CODE No. 13, **SETTING** and SET DATA (0004) change from flashing to ON state.

- ① Select the code No. 14 to set group setting with the ▲ , ▼ (**SET TEMP**) button.
- ② Set the No. of group setting as shown below with the ▲ , ▼ (⊕) button.

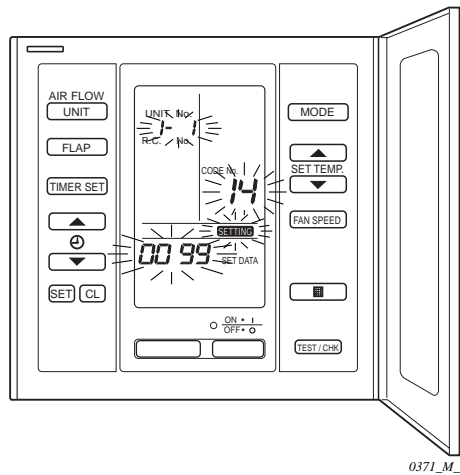

- Nos. of group setting.
- 0 : Standard system (except group control)
 - 1 : Main indoor unit in case of group control
 - 2 : Sub indoor unit in case of group control
 - 99: No setting (at factory shipment)

- ③ Press the **SET** button.
UNIT No., CODE No. 14, **SETTING** and SET DATA change from flashing to ON state.
- ④ If you made a mistake, press the **CL** button so that setting returns to the initial state.
- ⑤ Press the **TEST / CHK** button to finish this mode.
The display is disappeared.
- ⑥ Confirm the indoor unit address (UNIT No.) with the **UNIT** button after pressing the **ON / OFF** button.
- ⑦ Finally, remove the short circuit of DISP PIN.
And in case of group control, be sure to restore the branch wiring to its original wiring.
In case of remote controller-less system, remove the remote controller.

4-2 Checking the Electrical Components

(1) Measurement of Insulation Resistance

- The insulation is in good condition if the resistance exceeds 1 MΩ.

① Power Supply Wires

Clamp the earthed wire of the Power Supply wires with a lead clip of the insulation resistance tester and measure the resistance by placing a probe on either of the power wires. (Fig. 39)

Then measure the resistance between the earthed wire and the other power wire. (Fig. 39)

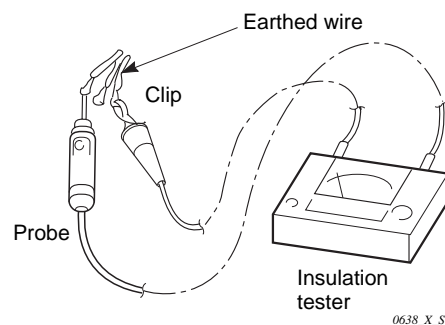

Fig. 39

② Indoor Unit

Clamp an aluminum plate fin or copper tube with the lead clip of the insulation resistance tester and measure the resistance by placing a probe on high voltage terminal on the terminal plate (Fig. 40)

See Fig. 28.

③ Outdoor Unit (SPW-C253GH5)

Clamp a metallic part of the unit with the lead clip of the insulation resistance tester and measure the resistance by placing a probe on ① and then ② on the 8 or 6P terminal plate.

(Fig. 40)

See Fig. 28.

③ Outdoor Unit (SPW-C253GH8, SPW-C363GH8, SPW-C483GH8)

Clamp a metallic part of the unit with the lead clip of the insulation resistance tester and measure the resistance by placing a probe on ⑤ and then ⑥, and then ⑦ on the 8P terminal plate. (Fig. 40)

See Fig. 29.

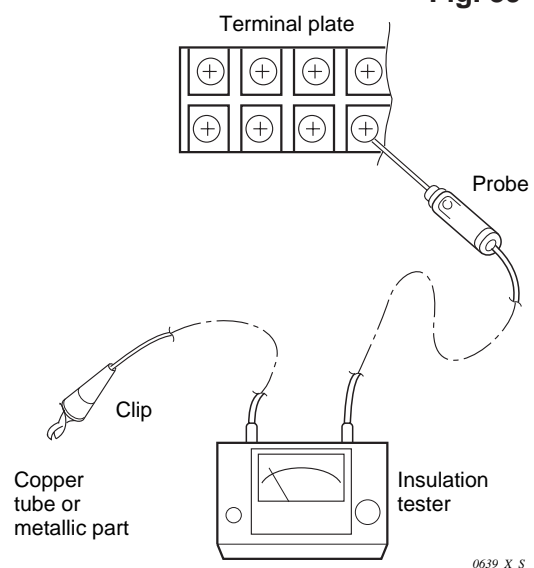
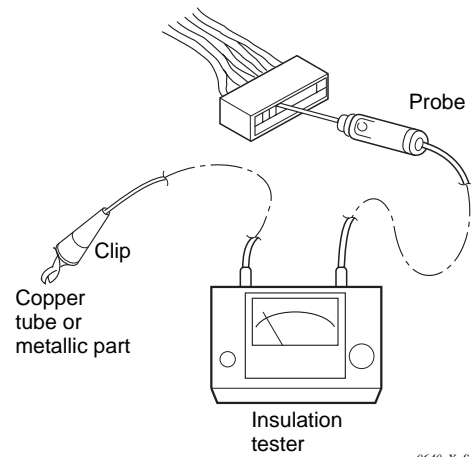

Fig. 40

④ **Measurement of Insulation Resistance for Electrical parts**

- Disconnect the connector of the desired electric part from terminal plate, P.C.B. Ass'y, etc. (**Fig. 42**)
- Similarly, disconnect the lead wires from compressor, capacitor, etc. (**Fig. 43**)
- Measure the resistance in the same manner as illustrated on the right.
Refer to Electrical Wiring Diagram.

NOTE
If the probe does not enter the hole because the hole is too narrow, use a probe with a thinner pin.



0640_X_S

Fig. 42

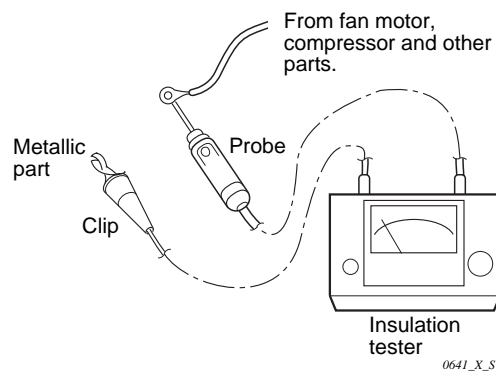

0641_X_S

Fig. 43

(2) Checking the Protective Devices

- Disconnect the connector, which consists of P (plug) and S (socket) when you want to check the protective device.
- Then check continuity among plug's (and/or socket's) terminal as in **Fig. 44**.
- Normality of the protective device can be judged by the following table. The Protective Device is proved normal if there is a continuity between terminals.

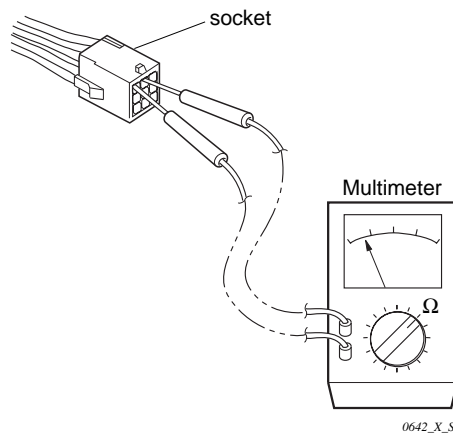

Fig. 44

- ① **Indoor fan motor thermal protector (49FI) Indoor unit**
 - Disconnect 9P connector (WHT) which leads to the indoor fan motor (FMI).
 - Check the socket's terminals between No. 8 (GRY lead wire) and No. 9 (GRY lead wire).
- ② **Compressor motor thermal protector (49C) Outdoor unit**
 - Only for the SPW-C253GH8 and SPW-C363GH8. Disconnect the 8P connector (white), and the 9P connector (white) on the P.C. board, and check 8P (white) plug's No. 4 (GRY lead wire) and socket's No. 9 (GRY lead wire) on the P.C.board.
- ③ **Outdoor fan motor thermal protector (49FO) Outdoor unit**
 - Disconnect 8P connector(s) (WHT) which lead(s) to the outdoor fan motor (FMO).
 - Check socket's terminal between No. 3 (GRY lead wire) and No.4 (GRY lead wire).
- ④ **High pressure switch (63PH) Outdoor unit**
 - Disconnect the socket (63PH) of 3P (red) connecting to the P.C. board, and check both sides (1 (white), 3 (red)).

(3) Checking the Electrical Parts

- ① **Power transformer (TR1) Indoor unit** *Measure the coil resistance.
- Primary ; Measure the resistance between No.1 and No.3 (WHT lead wires) terminals of 3P (WHT) socket connected to power transformer.
 - Secondary 14V ; Measure the resistance between No.1 and No.2 (RED lead wires).
10V ; Measure the resistance between No.3 and No.4 (BRN lead wires).

Refer to “1-3 Other component specifications”.

- ② **Power transformer (TR2) Outdoor unit** *Measure the coil resistance.
- Primary ; Measure the resistance between No.1 and No.3 (WHT lead wires) terminals of 3P(WHT) socket jointed to power transformer.
 - Secondary 14 V ; Measure the resistance between No.1 and No.2 (BRN lead wires).

Refer to “1-3 Other component specifications”.

- ③ **Indoor fan motor (FMI) Indoor unit** *Measure the coil resistance.
- Measure the resistance between each terminal of 9P (WHT) socket connected to the indoor fan motor.

Refer to “1-2-(A) Major component specifications”.

- ④ **Outdoor fan motor (FMO) Outdoor unit** *Measure the coil resistance.
- Measure the resistance in the same manner as explained above ③.

Refer to “1-2-(B)Major component specifications”.

- ⑤ **Fan motor capacitor Both in indoor and outdoor unit**
- Remove the lead wires from the capacitor terminals, and then place a probe on the capacitor terminals as shown in **Fig. 45**. Observe the deflection of the pointer, setting the resistance measuring range of the multimeter to the maximum value.
 - The capacitor is “good” if the pointer bounces to a great extent and then gradually returns to its original position.

NOTE

The range of deflection and the deflection time differ according to the capacity of the capacitor.

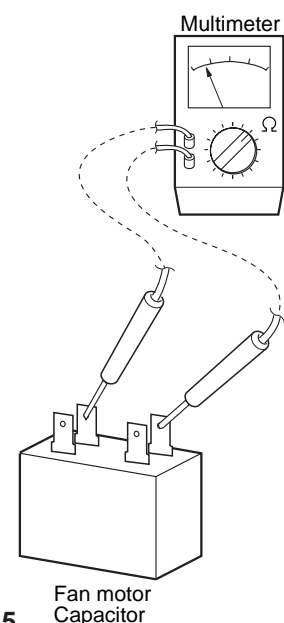

Fig. 45

Fan motor Capacitor

0643_X_S

⑥ **Solenoid coil of the electronic refrigerant control valve (ERCV) Indoor unit** *Measure the coil resistance.

- Measure the resistance between No. 5 (GRY lead wire) and other terminals (another color of lead wires) of 5P (WHT) plug connected to the solenoid coil.
Refer to “1-2-(A) Major component specifications”.

⑦ **Compressor motor (CM) Outdoor unit** *Measure the coil resistance.

• **In case of triple -phase compressor**

Measure the resistance between “R” (RED lead wire) and “S” (WHT lead wire) terminals, “R” and “T” (BLU lead wire) terminals and “S” and “T” terminals on the compressor motor magnetic contactor.

• **In case of single -phase compressor**

Remove the cover of compressor terminal and measure the resistance between terminals.

Refer to “1-2 Major component specifications”.

⑧ **Compressor motor magnetic contactor (52C) Outdoor unit**

- Measure the resistance between A (ORG lead wire) and B (GRY lead wire) terminals on the compressor motor magnetic contactor.

Refer to “1-3 Other component specifications”.

- Check the continuity between contactors.

MODEL	FMCA-1S			
Push button on the magnetic contactor	Pair of terminals			
	R - U	S - V	T - W	31 - 32
no press	—	—	—	YES
press	YES	YES	YES	—

⑨ **Solenoid coil of 4-way valve (20S) ... Outdoor unit**

*Measure the coil resistance.

- Measure the resistance between No.1 (BLU lead wire) and No.2 (BLU lead wire) terminals of 2P (YEL) socket connected to the solenoid coil.

Refer “1-3 Other component specifications”.

⑩ **Fuse on indoor and outdoor P.C.B. Ass'y Both in indoor and outdoor unit**
*Check the continuity.

- Remove the P.C.B. Ass'y from the electrical component box. Then pull out the fuse from the P.C.B. Ass'y. **(Fig. 46)**

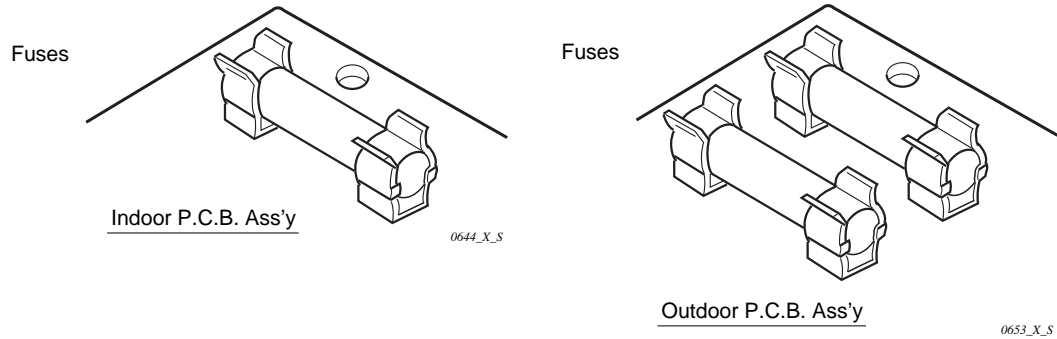

Fig. 46

- Then check the continuity of the fuse by using the multimeter. **(Fig.47)**

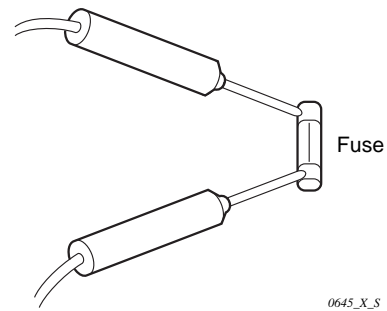
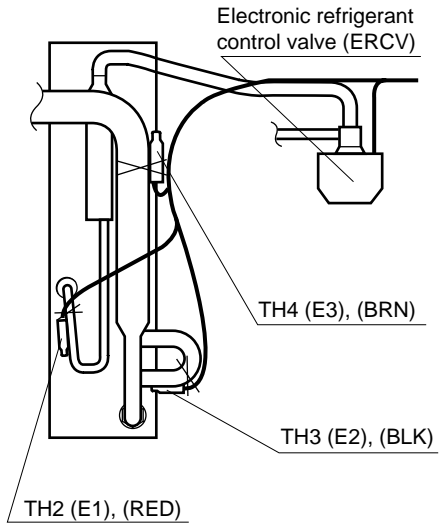

Fig. 47

(4) Sensor and Solenoid Layout Diagram

Indoor Unit

- SPW-D253GH56



- SPW-D363GH56
- SPW-D483GH56

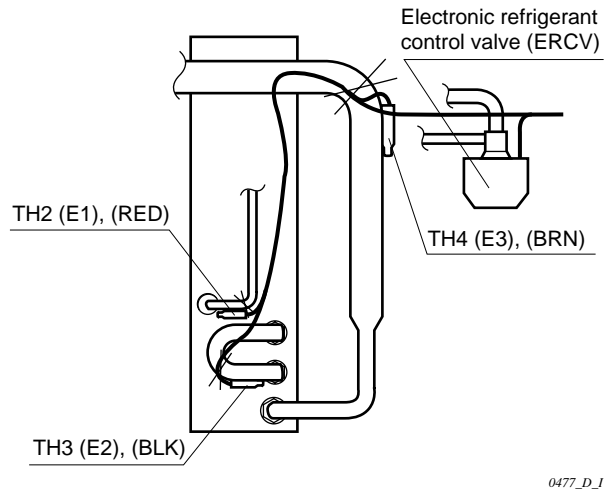

Outdoor Unit

- SPW-C253GH5, SPW-C253GH8

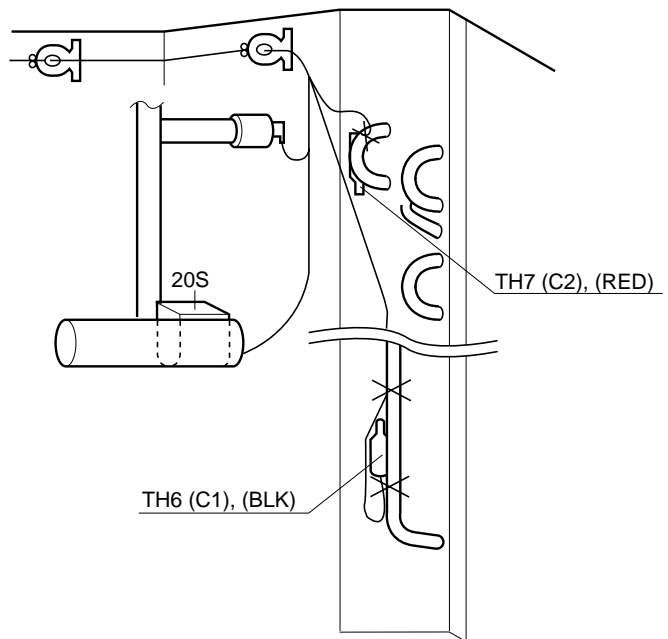
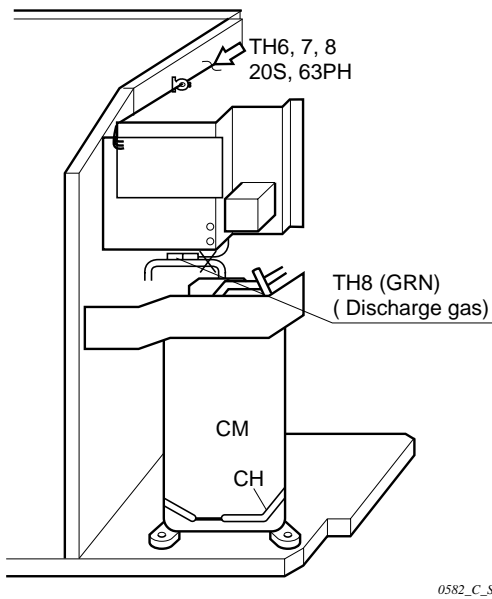

• SPW-C363GH8

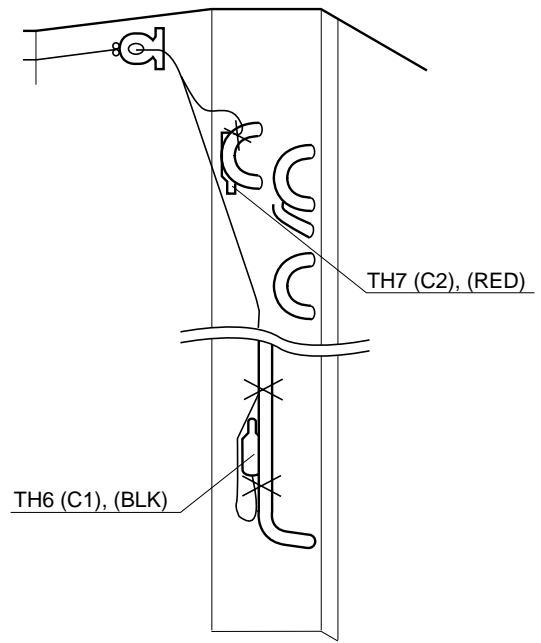
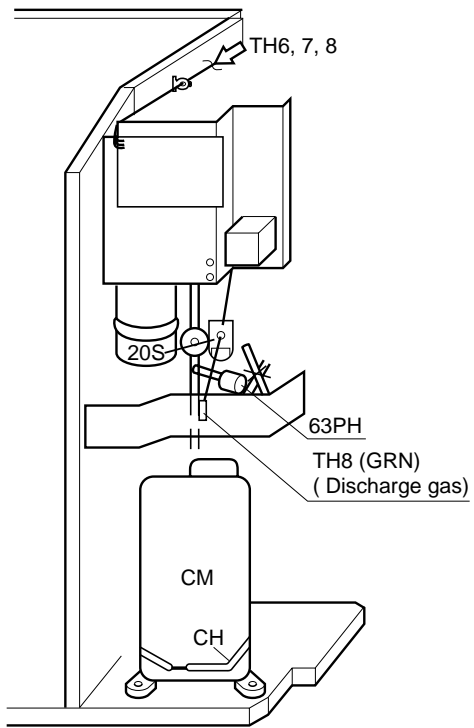

• SPW-C483GH8

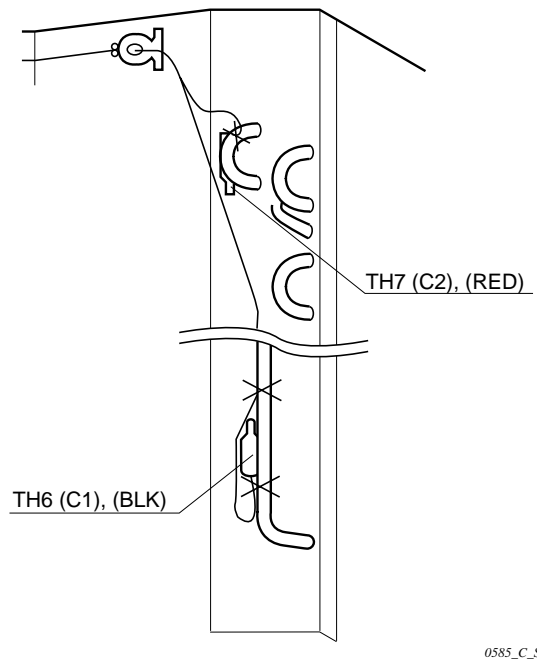
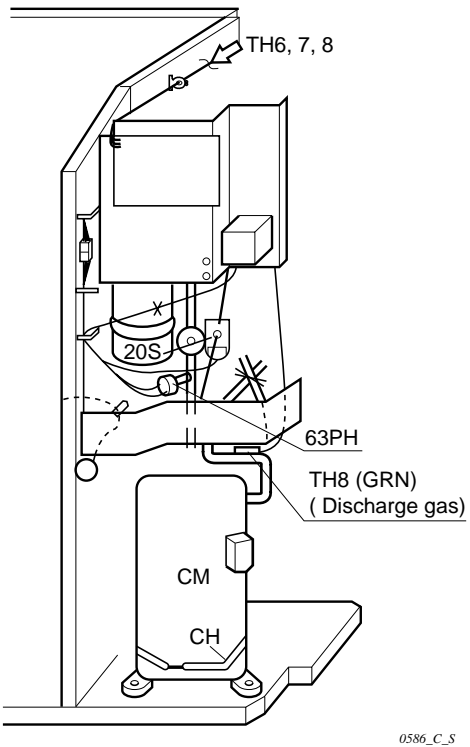

(5) Thermistor Characteristic Curve

(1) Room temp. sensor : TH1 (KTEC-35)

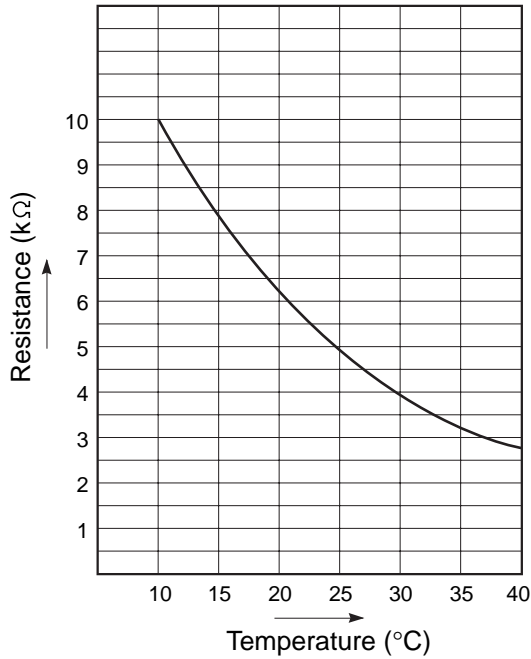

(2) Indoor heat exch. coil sensor : TH2(E1), TH3(E2), TH4(E3)

Outdoor heat exch. coil sensor : TH6(C1), TH7(C2)

(PBC-41E)

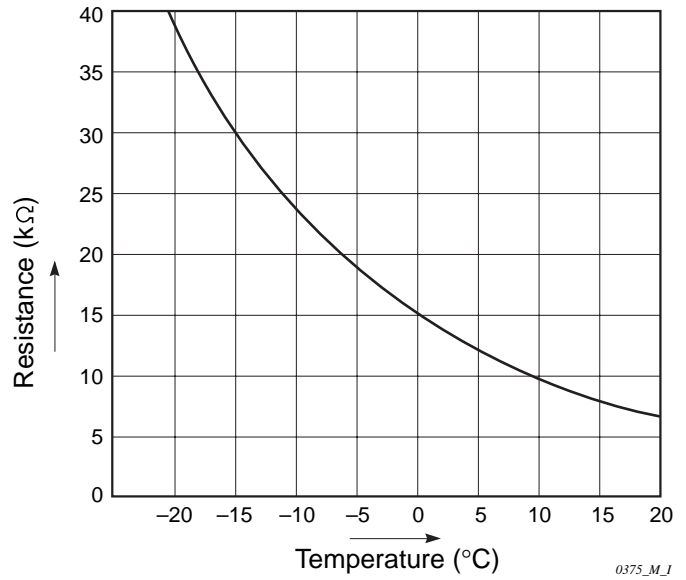

(3) Compressor discharge gas temp. sensor : TH8 (PTC-51H)

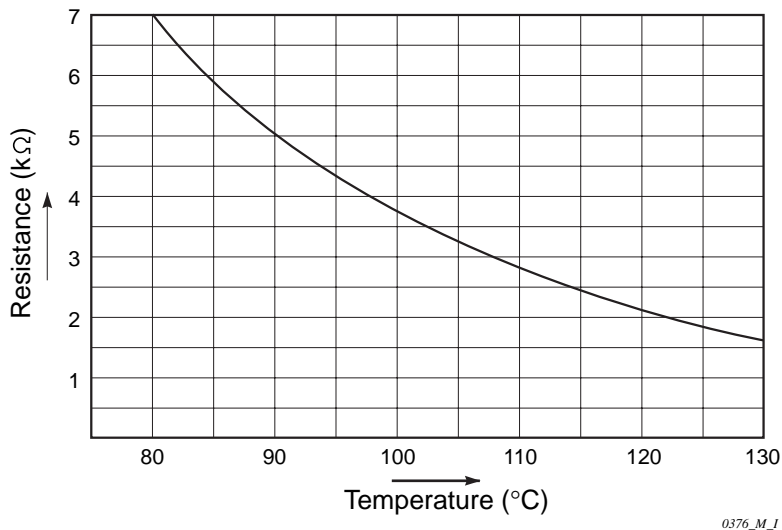

(6) PCB Setting

● Setting of outdoor control PCB

(A) Standard control (single outdoor unit)

In case of single outdoor unit installation, no indoor unit's setting is necessary for twin, triple or quartet types (2, 3 or 4 indoor units).

Keep R.C. address setting at "0" as factory shipment state.

In this case, auto. address operation is performed automatically for the first time when the power is switched on. This operation takes about a few minutes.

(B) Group control (Multiple outdoor units)

In case of group control (up to 8 indoor units can be connected with one remote controller), before turning on the power supply, set the R.C. address with S2, S3 on the outdoor control PCB.

R.C. address: Refrigerant circuit address 1 ~ 30.

Regarding the example of R.C. address for group control, please refer to R.C. Address Setting Method.

(C) Central control (when using the system controller)

In case of central control (when using the system controller, that is, when linking outdoor units in a network),

- (a) Before turning the power supply on, set the R.C. address with S2, S3 on the outdoor control PCB.
- (b) Remove the short plug (CN4, 2P Black) from all outdoor units except one outdoor unit.

Regarding the example of R.C. address for central control and the position of CN4, please refer to R.C. Address Setting Method.

● Setting of indoor control PCB

No setting is necessary.

Each indoor unit address (UNIT No.: R.C. – No.) is decided after auto. address operation.

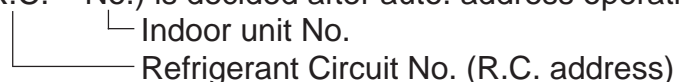

Manual setting for indoor unit address can be performed also by remote controller.

(7) R.C. Address Setting Method

Outdoor unit R.C. address setting method

In case of group control or central control, set the R.C. address to 1, 2, 3, ... according to the No. of outdoor units.

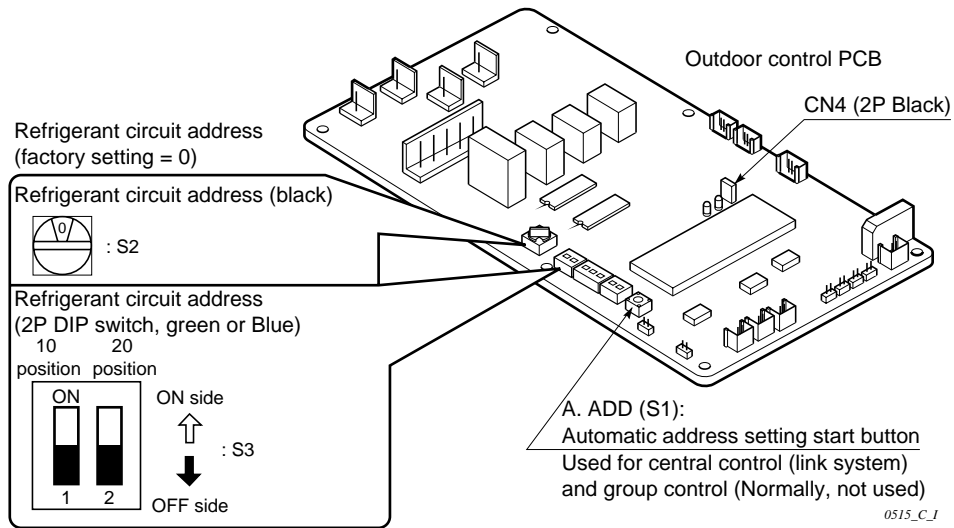

R.C. address	R.C. address (S3: 2P dip switch, green or Blue)	R.C. address (S2: Rotary switch, Black)
00 auto address ("0" when shipped from factory)	Both OFF	Set to 0
02 (In case of No. 2 outdoor unit)	Both OFF	Set to 2
03 (In case of No. 3 outdoor unit)	Both OFF	Set to 3
11 (In case of No. 11 outdoor unit)	10's SW is ON	Set to 1
21 (In case of No. 21 outdoor unit)	20's SW is ON	Set to 1
30 (In case of No. 30 outdoor unit)	Both 10's and 20's switches are ON	Set to 0

(8) Automatic Address Setting Method

— For group control and central control with multiple outdoor units —

Carry out automatic address setting with the remote controller.

- 1) All auto. address operation
 - ① Press the **TEST / CHK** and **▲ (⊕)** buttons at the same time for more than 4 seconds.
 - ② Press the **SET** button after confirming the CODE No. AA (CODE No. AA: All Auto. address operation).
After addresses are automatically set in order for the outdoor units from No. 1 to No. 30, the system returns to the normal stopped state.
- 2) Individual auto. address operation for each refrigerant circuit
 - ① To select each refrigerant circuit individually and set addresses automatically, press the **TEST / CHK** and **▲ (⊕)** buttons at the same time for more than 4 seconds, then press the **▲ , ▼ (SET TEMP)** button once to set CODE No. A1. (CODE No. A1: Auto. address operation)
 - ② Select R.C. No. which you want to execute the auto. address operation with **UNIT** button.
 - ③ Press the **SET** button. The auto. address operation will start. CODE No. changes from flashing to ON state.
 - ④ If the error occurred during the operation, the alarm message will be displayed. Check and remove the cause. If you want to interrupt the operation, press the **CL** button then the unit stands in waiting mode (Press the **SET** button).
 - ⑤ If the auto. address operation finishes, the display will disappear.
 - ⑥ Execute the operation of the other R.C. line in the same way by following the above steps ② to ③.
 - ⑦ Complete the auto. address operation by pressing the **TEST / CHK** button.

NOTE

Required time for auto. address operation:

In case of group control : a few minutes for each R.C.

In case of central control : max. about 20 min. for each R.C.

(9) Displaying Indoor / Outdoor Unit Combination Numbers

Display the indoor / outdoor unit address after automatic address setting.

- 1) When installing multiple units, match the indoor unit address numbers and the outdoor R.C. address numbers and display them at an easy-to-check location (near the nameplate) with an oil-based magic marker or other indelible marker so that the individual indoor and outdoor unit combinations can be checked.

Example:

Outdoor Unit 1 – Indoor Units 1-1, 1-2, 1-3, ...

Outdoor Unit 2 – Indoor Units 2-1, 2-2, 2-3, ...

- 2) Displaying indoor / outdoor unit address is necessary for maintenance. Always label numbers. *Check indoor unit address with the remote controller. Press the **TEST / CHK** button for at least 4 seconds and check the indoor unit address with the **UNIT** button. (Each time you press the **UNIT** button, the address changes 1-1, 1-2, ... 2-1, 2-2, ...) The fan for only the selected indoor unit turns on at high speed, so check which indoor unit runs and label the indoor unit address.
(If there is 1 outdoor unit, the addresses are 1-1, 1-2, ...)
When you press the **TEST / CHK** button again, the system returns to normal remote control mode.

(10) Items to Check Prior to Test Run

- 1) Turn on the power supply switch more than 5 hours before in order to charge the crank case heater.
- 2) Fully open the outdoor service valve after making the leak inspection of field connected tubing, vacuuming, and gas charging if necessary.
- 3) Check the capacity code and model code setting.
 - * The factory setting is as shown in the table.
 - * The capacity code is set by S4 (green or Blue 4P DIP switch) on outdoor control PCB.

The model code is set by S5 (black, 2P DIP switch) on outdoor control PCB.

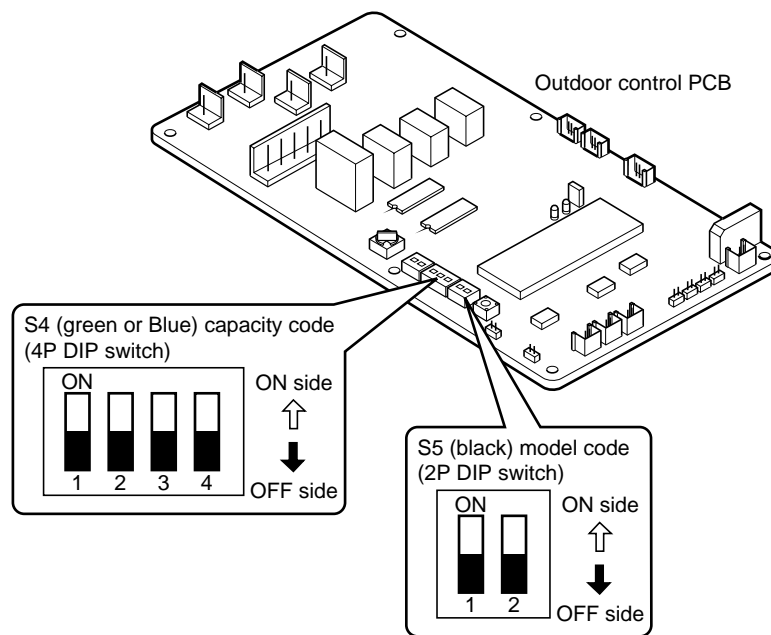

0510_C_1

S4. Capacity code

Model No. \ No.	Outdoor PCB			
	1	2	3	4
25 type (1 phase)	ON	ON	ON	OFF
25 type (3 phase)	ON	ON	ON	OFF
36 type (3 phase)	OFF	ON	OFF	ON
48 type (3 phase)	OFF	OFF	ON	ON

S5. Model code

Model No. \ No.	Outdoor PCB	
	1	2
25 type (1 phase)	ON	OFF
25 type (3 phase)	OFF	OFF
36 type (3 phase)	OFF	OFF
48 type (3 phase)	OFF	ON

(11) Test Run Procedure

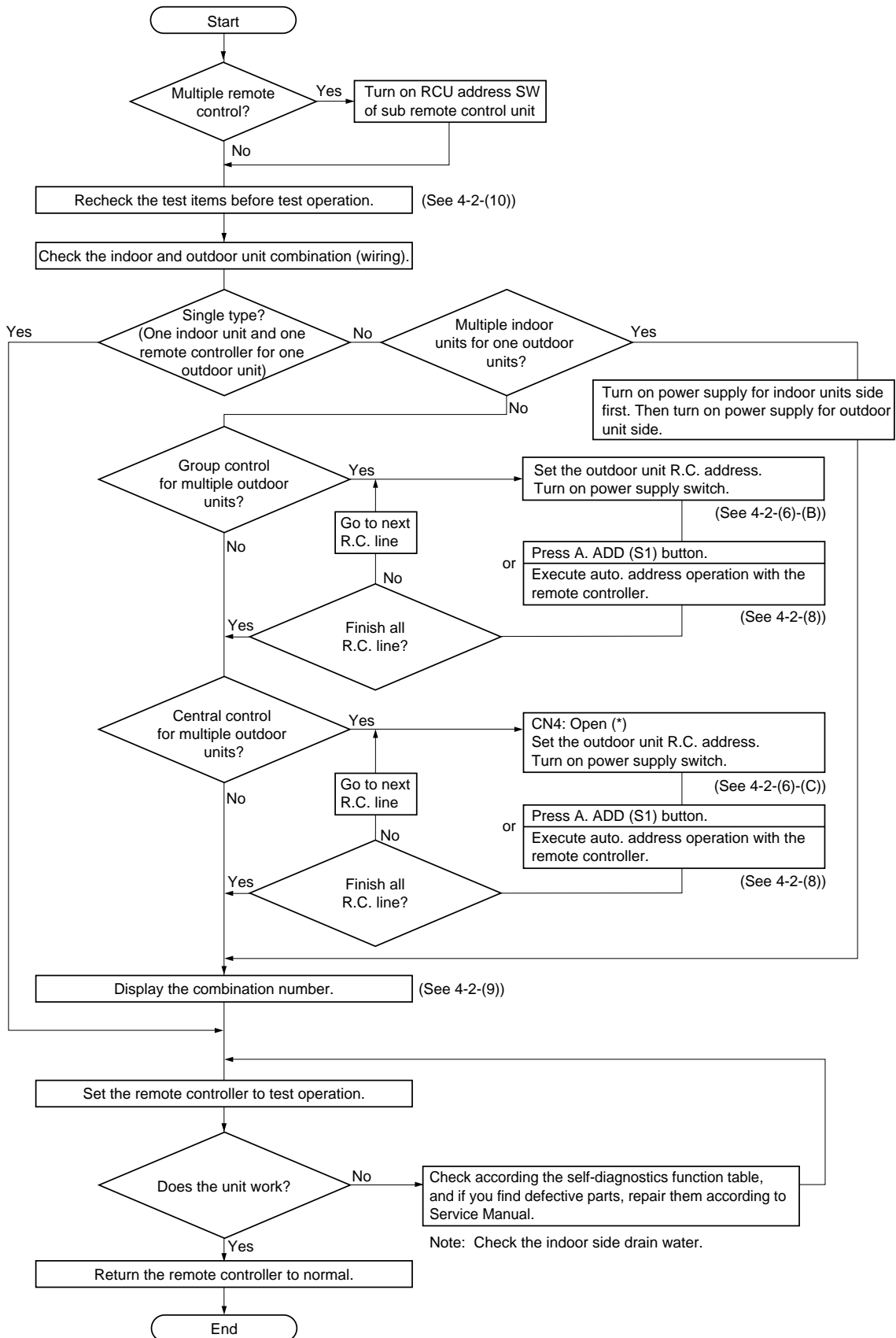

4

NOTE

- 1) One of CN4 of all linked outdoor units should be short.
- 2) In case of using system controller, zone registration is required after finishing Test run. Regarding the zone registration, please refer to Installation Instructions attached with system controller.

0676_M_1